

Ⓑ - models

2017



Budget - Line

Euro-Tank-Car.eu

Van Biervliet.com

online versie : 26 jan 2017

Ⓑ - models



Om te voldoen aan de stijgende vraag van Belgische modellen, besliste de Treinwinkel Van Biervliet uit Ingelmunster om eigen modellen te gaan ontwikkelen en te verdelen. Het eigen merk kreeg de naam B-models.

Vandaag is B-models niet alleen een klein-serie fabrikant van Belgische modellen, maar produceert het merk ook vele internationale wagens en locomotieven



Um der steigenden Nachfrage für belgische Modellen gerecht zu werden, entschied das Modelleisenbahngeschäft Van Biervliet aus Ingelmunster (belgien), seine eigenen Modelle unter der Marke B-Models zu entwickeln und zu vertreiben.

B-Models ist heute nicht nur ein Kleinserienhersteller belgischer Eisenbahnmodelle, sondern produziert auch viele internationale Eisenbahnwagen und Lokomotiven.



Due to the high demand for belgian railway models, the Model Railway Shop Van Biervliet from Ingelmunster (Belgium) decided to develop and sell its own models under the brand B-Models.

B-Models isn't only a limited serie producer ,but it produces now also many international cars and locomotives.



Pour mieux répondre à la demande croissante des modèles ferroviaires belges, le magasin de train Van Biervliet à Ingelmunster (Belgique) a décidé de développer et vendre ses propres modèles ferroviaires sous la marque B-Models.

B-Models n'est aujourd'hui pas seulement un fabricant de petite série de modèles ferroviaires belges, mais également producteur de nombreux wagons et locomotives internationales.

Family Team of B-Models / Van Biervliet :



Sophie

Administration / orders / distribution

Kristof

Project Leader

Jack

Technical check

Lokomotiven

-

Locomotives

-

Trains

AM 54 NMBS / SNCB



De AM54 is de benaming van een type treinstel van de NMBS. De treinstellen maakten deel uit van de klassieke motorstellen waarvan er tussen 1939 en de jaren 70 van de twintigste eeuw ongeveer 500 op het spoor verschenen. 15 stellen uit de serie AM 54 zijn in 1988 omgebouwd tot posttreinstellen voor De Post.

In de jaren 90 zijn de meeste stellen afgevoerd voor sloop.

Een aantal treinstellen van deze serie kreeg een tweede leven bij particuliere spoorwegmaatschappijen in Italië.



Der AM54 ist der Name einer Triebwagengattung der NMBS. Diese Triebwagen waren ein Teil der sogenannten klassischen Triebwagen die ab 1939 und den siebziger Jahren mit etwa 500 Einheiten auf dem Schienennetz erschienen sind.

15 Einheiten der AM54 wurden 1988 für La Poste zu Post-Triebwagen umgebaut. In den neunziger Jahren wurden die meisten zu Verschrottung abgestellt. Einige dieser Triebwagen wurden an italienische Privatbahnen verkauft, und verrichten dort noch ihren Dienst.



The AM54 is a typical NMBS multiple unit. These trains were produced as a 'classic railtrain' in Belgium. About 500 pcs of these AM multiple units ran between 1939 and 1970.

15 models of the serie AM 54 are transformed in 1988 into post-trains for the Belgium Post.

In the 90s most of these trains were scrapped.

Some of them received a second life at some local railway companies in Italy.



Le AM54 est le nom d'un type d'automotrice de la SNCB. Ces automotrices faisaient partie des automotrices classiques qui sont apparues sur le réseau avec 500 unités à partir de 1939 et les années 70.

En 1988 15 unités de cette série ont été transformées en automotrices postales pour La Poste.

Dans les années 90 la plupart de ces automotrices ont été mises à la ferraille.

Certaines automotrices de cette série ont été vendues à des entreprises ferroviaires privées en Italie.

AM 54 NMBS / SNCB



Prototype



Prototype

Ref.				
7001.01	2-Rails = CC	Courant continu	Gelijkstroom DC	conventioneel
7001.02	“	Courant continu digital	“	Digitaal
7001.03	“	CC digital SOUND	“	Digitaal Sound

Ref.			
7001.04	3-Rails ~ CA	for/pour/voor Märklin* system	: Digital Mfx*
7001.05	“		: Digital Sound Mfx*

OPTIE 1 : dubbele, wisselende cabineverlichting + interieurverlichting

OPTION 1 : double éclairage cabine + éclairage d'intérieur

OPTION 1 : changing cabine lights + interior lights

NMBS / SNCB AM Post

1988 wurde der erste Triebwagen der 15 Einheiten dem Publikum vorgestellt .

Diese Triebwagen wurden auf Basis des AM 54 neu aufgebaut.

Alle noch im Dienst befindliche Triebwagen erhielten die neue Farbgebung der La Poste zwischen 1998 und 1999.



Nach der Entscheidung von La Poste, den Post-Verkehr von der Schiene auf die Straße zu übertragen, gab es für die meisten Triebwagen ab dem 1. April 2003 keine Verwendung mehr. Nur die Einheiten die zwischen Brüssel und Gent-Sint-Pieters unterwegs waren, blieben noch bis zum 13 Oktober 2003 in Betrieb.



In 1988, werden de eerste van 15 posttreinstellen voorgesteld aan de pers.

Deze stellen zijn gemaakt op basis van de AM 54. Alle treinstellen werden omgeschilderd naar de rode post kleur tussen 1998 en 1999.

Na de beslissing door de post om het transport via de weg te doen, werden de stellen buiten dienst gezet op 1 april 2003. Behalve enkele stellen die nog dienst deden tussen Brussel en Gent Sint Pieters (tot 13 oktober 2003).



In 1988 the first multiple unit of 15 pcs are announced to the press.
 These multiple unit are modified AM 54 passenger railtrains.

All the models are painted in red Post color between 1998 et 1999.

But after a decision to transport the post by road, these trains are out of service from april 2003.

Only a few, between Brussels and Ghent were in circulation till October 2003.



sofort lieferbar - disponible - leverbaar - available

AM POST : Model nr 961 : ' POST 90 - POSTE 90 '

Ref.				
7201.01	2-Rails = CC	Courant continu	Gelijkstroom DC	conventioneel
7201.02	“	Courant continu digital	“	Digitaal
7201.03	“	CC digital SOUND	“	Digitaal Sound

Ref.			
7201.04	3-Rails ~ CA	for/pour/voor Märklin* system	: Digital Mfx*
7201.05	“		: Digital Sound Mfx*



NMBS / SNCB AM Post



AM POST : Model nr 974 : ' POST - NEW LOGO '

Ref.				
7202.01	2-Rails = CC	Courant continu	Gelijkstroom DC	conventioneel
7202.02	“	Courant continu digital	“	Digitaal
7202.03	“	CC digital SOUND	“	Digitaal Sound

Ref.			
7202.04	3-Rails ~ CA	for/pour/voor Märklin* system	: Digital Mfx*
7202.05	“		: Digital Sound Mfx*



Prototype

AM Post 974 new logo



Prototype



Treinstel AM 86 - 'DUIKBRIL'

De AM 86 is een elektrisch treinstel van de Belgische spoorwegmaatschappij NMBS, dat gebouwd werd in de periode 1986-1991. Het is tweedelig en heeft aan beide kanten een stuurpost. Het is te herkennen aan de typische kopwanden, die de vorm van een duikbril hebben. Daarom wordt de AM 86 ook de Duikbril genoemd. Een andere bijnaam is "Sprinter".



VB-4003

Nr 945 : in het midden 1 compartiment 1°klasse (laatste bordeaux versie)

Nr 945 : au milieu 1 compartiment 1ère classe (dernière version bordeaux)

Nr 945 : in the middle only 1 compartment 1° class (last production red version)

Version			Versie		
VB-4003.02	<i>pour Märklin*</i>	Digital Mfx	VB-4003.02	<i>voor Märklin*</i>	Digitaal Mfx
VB-4003.04	“	Digital SOUND Mfx	VB-4003.04	“	Dig.SOUND Mfx

VB-4003.05	<i>2-Rails = CC</i>	Courant continu	VB-4003.05	<i>Gelijkstroom DC</i>	conventioneel
VB-4003.06	“	Courant continu digital	VB-4003.06	“	Digitaal
VB-4003.07	“	CC digital SOUND	VB-4003.07	“	Digitaal Sound

OPTIE 1 : dubbele, wisselende cabineverlichting + interieurverlichting

OPTION 1 : double éclairage cabine + éclairage d'intérieur



Automotrice AM 86 - 'Sprinter'

La série 09 est une série d'automotrices doubles (deux voitures) de la SNCB ; elles sont appelées plus couramment Sprinter (prononcé sprintèrre) ou encore AM 86 d'après l'année de début de construction : de 1986 à 1991. Elle est caractéristique par sa paroi frontale typique qui a la forme d'un masque de plongée).



Die Reihe AM 86-89 (auch Reihe 09) der Belgischen Staatsbahn (NMBS/SNCB) ist eine Baureihe von 120 km/h schnellen zweiteiligen Elektrotriebfahrzeug-Einheiten für den Betrieb mit 3 kV Gleichstrom.

Wegen der charakteristischen Stirnfront aus Polyester haben die Fahrzeuge den Spitznamen Duikbril (=Taucherbrille) erhalten.



VB-4004

Nr 911 : in de New-Look versie

Nr 911 : en version New-Look

Nr 911 : in the New-Look colors

Version		Versie
VB-4004.02	<i>pour Märklin*</i> Digital Mfx	VB-4004.02 <i>voor Märklin*</i> Digitaal Mfx
VB-4004.04	“ Digital SOUND Mfx	VB-4004.04 “ Dig.SOUND Mfx

VB-4004.05	<i>2-Rails = CC</i> Courant continu	VB-4004.05 <i>Gelijkstroom DC</i> conventioneel
VB-4004.06	“ Courant continu digital	VB-4004.06 “ Digitaal
VB-4004.07	“ CC digital SOUND	VB-4004.07 “ Digitaal Sound

OPTIE 1 : dubbele, wisselende cabineverlichting + interieurverlichting

OPTION 1 : double éclairage cabine + éclairage d'intérieur

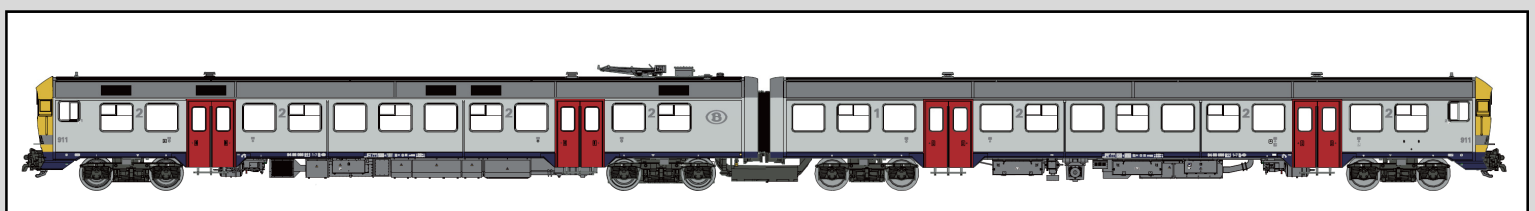

VB-6001 : 3-Delig elektrisch Treinstel « Desiro 08179 »

- Das Modell wird detailgetreu produziert, und wird mit einem LED Lichtwechsel als Serienausstattung ausgerüstet.
- Fein detailliertes Dach und Fahrwerk. - Mit Messingelementen.
- Innenraum in allen drei Teilen vorhanden.
- Mit einem 21 poligem ESU Dekoder, der Sounddeko ESU V4/M4/Railcom+
- Das Modell kann noch zusätzlich mit einer Innenraumbelichtung sowie einer Reiseziel-Matrix ausgestattet werden (Option 1).
- in auslieferung.



- le modèle sera reproduit en détails et équipé de série avec éclairage LED blanc/rouge
- toit et châssis finement détaillés
- avec éléments en laiton - intérieur dans les 3 parties
- avec décodeur 21 pôles, la version sonore digitale avec V4/M4/Railcom + décodeur
- le modèle peut-être équipé de l'éclairage intérieur et affichage de destination (voir option 1)
- équipé d'attelages spéciaux entre les éléments comme appliqué sur notre AM 86
- en cours de livraison



- Het model zal tot in de details geproduceerd worden, standaard met LED verlichting wit/rood.
- fijne details zowel op het dak als onder het treinstel
- met messing elementen - met interieur in alle drie de delen
- met 21-polige ESU decoder stekker , bij digitale sound versie met ESU V4/M4/Railcom+ decoder
- het model kan uitgerust worden met binnenverlichting en bestemmingsbord- zie optie 1
- productie : in uitlevering



Versies 3-delige DESIRO / Versions 3 éléments DESIRO

Version		Versie
VB-6001.2	<i>pour Märklin*</i> Digital Mfx	2 <i>voor Märklin*</i> Digitaal Mfx
VB-6001.4	“ Dig. SOUND Mfx	4 “ Dig.SOUND Mfx

VB-6001.5	<i>2-Rails = CC</i> Courant continu	5 <i>Gelijkstroom</i> conventioneel
VB-6001.6	“ Courant continu digital	6 “ Digitaal
VB-6001.7	“ CC digital SOUND	7 “ Digitaal Sound

OPTIE 1 : dubbele, wisselende cabineverlichting + interieurverlichting in de 3 rijtuigen + schakelbaar 'bestemmingsbord' op front.

OPTION 1 : double éclairage cabine + éclairage intérieur dans les 3 voitures + l'affichage de destination interchangeable à l'avant



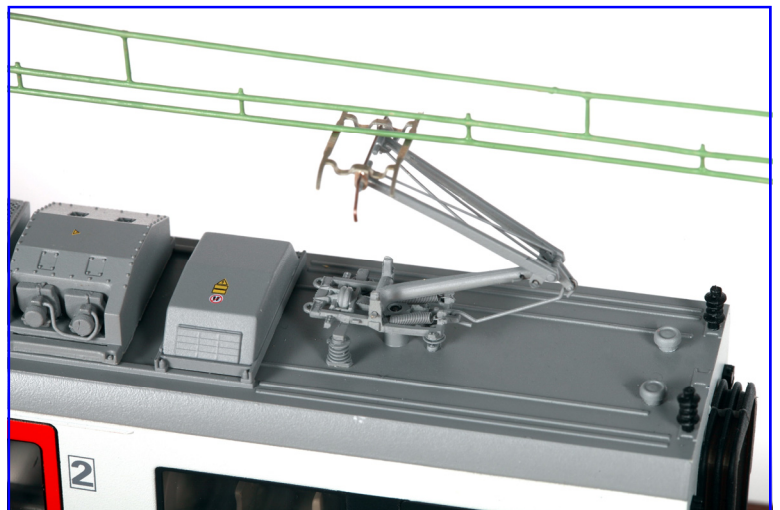

CFL 1811

20.205 DC =
20.905 DC = digital
21.205 DC = digit.Sound
22.205 AC ~ digital
23.205 AC ~ digit.Sound

Ep III
LUXEMBOURG

sofort lieferbar - disponible - leverbaar - available



CFL 1805 *Italic*

- | | | | |
|--------|------------------|--------|------------------|
| 20.206 | DC = | 22.206 | AC ~ digital |
| 20.906 | DC = digital | 23.206 | AC ~ digit.Sound |
| 21.206 | DC = digit.Sound | | |

Ep IV
LUXEMBOURG



CFL 1815 "KAUTENBACH"

- | | | | |
|--------|------------------|--------|------------------|
| 20.207 | DC = | 22.207 | AC ~ digital |
| 20.907 | DC = digital | 23.207 | AC ~ digit.Sound |
| 21.207 | DC = digit.Sound | | |

Ep V-VI
LUXEMBOURG



NMBS 5539

20.121	DC =	22.121	AC ~ digital
20.821	DC = digital	23.121	AC ~ digit.Sound
21.121	DC = digit.Sound		

NEW 17

Ep IV
GOUVY



NMBS 5519

20.122	DC =	22.122	AC ~ digital
20.822	DC = digital	23.122	AC ~ digit.Sound
21.122	DC = digit.Sound		

NEW 17

Ep IV
KINKEMPOIS

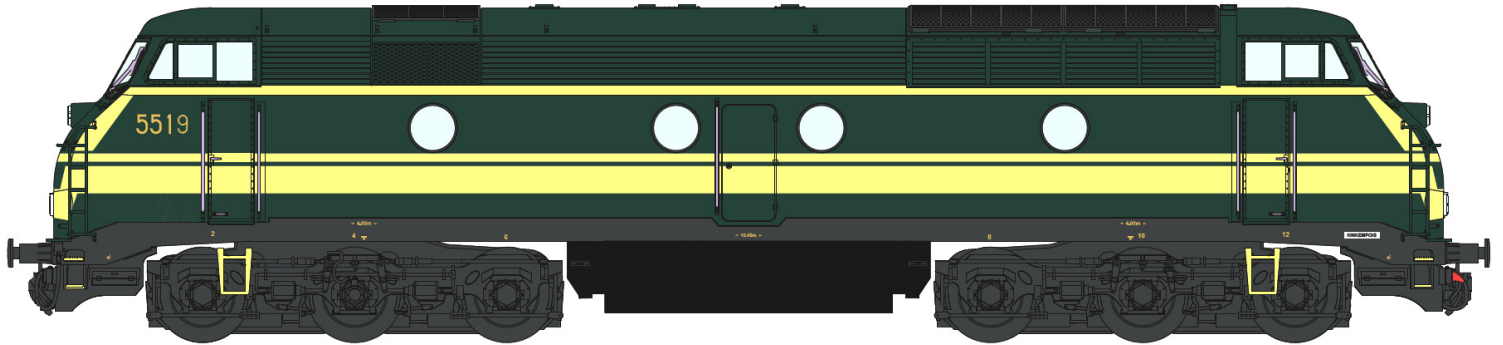

NMBS 5506 NEW

20.123	DC =	22.123	AC ~ digital
20.823	DC = digital	23.123	AC ~ digit.Sound
21.123	DC = digit.Sound		

NEW 17

Ep VI
SCHAERBEEK

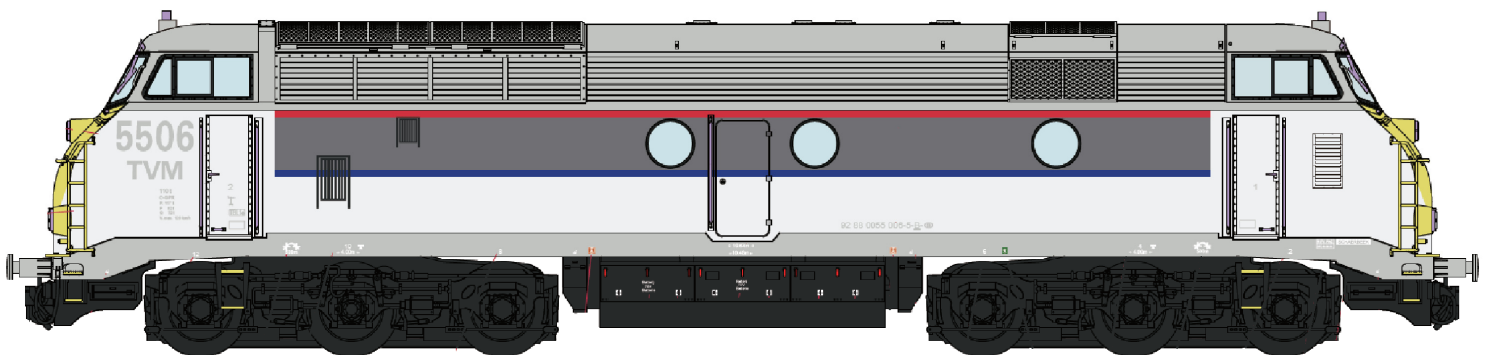

NMBS 5506 New Look

Aan 1 zijkant slechts 3 ronde ruitjes.



Bij de 5506 is de plaatsing van de tekst 'TVM en TBL1+' verschillend aan 1 zijde van de lok.



NEW sound decoder from ESU V4/M4/Railcom + with original NOHAB sound ! and more than 20 functions !
 Digital versions with Power Pack. Sound versions with the ESU smoke generator system

If you want a digital version, please order directly this version. The DC normal version can't be modified / upgraded to a digital or digital Sound version because of the Power Pack

Artikel VB-9210 : SNCB / NMBS loc 5319 with 4 lightslights

Extra ventilater on roof - Depot : Latour - Ep. : IV

VB-9210.01 DC =

VB-9210.02 DC = Digital

VB-9210.03 DC = dig.Sound

VB-9210.04 AC ~ Digital

VB-9210.05 AC ~ dig.Sound

Digital version = with Power Pack

Sound version = with Dynamic Smoke and Power Pack



Artikel VB-9211 : SNCB / NMBS loc 5406 with 5 lights

5 lights - number 5406 lower - Depot : Ronet - Ep. : IV

VB-9211.01 DC =

VB-9211.02 DC = Digital

VB-9211.03 DC = dig.Sound

VB-9211.04 AC ~ Digital

VB-9211.05 AC ~ dig.Sound

Digital version = with Power Pack

Sound version = with Dynamic Smoke and Power Pack



coming soon .. end febr.



Artikel VB-9206 : TMY 1150 Railcare

VB-9206.01 DC = 169,00 €

VB-9206.02 DC = Digital 199,00 €

VB-9206.03 DC = dig.Sound 339,00 €

VB-9206.04 AC ~ Digital 199,00 €

VB-9206.05 AC ~ dig.Sound 339,00 €

Sound versie = with Dynamic Smoke System and Free Power Pack



Artikel VB-9212 : Lollandsbanen M 38

VB-9212.01 DC =

VB-9212.02 DC = Digital

VB-9212.03 DC = dig.Sound

VB-9212.04 AC ~ Digital

VB-9212.05 AC ~ dig.Sound

Digital version = with Power Pack

Sound version = with Dynamic Smoke and Power Pack



Prototype



Artikel VB-9213 : DSB 21105



Prototype

Artikel VB-9214 : CFL loc 1604 with 3 lights

VB-9214.01 DC =

VB-9214.02 DC = Digital

VB-9214.03 DC = dig.Sound

VB-9214.04 AC ~ Digital

VB-9214.05 AC ~ dig.Sound

Digital version = with Power Pack

Sound version = with Dynamic Smoke and Power Pack



Artikel VB-9205 : DSB loc 1158 ContecRail



Rerun - 2° production

Artikel VB-9207 : SNCB / NMBS loc 5404 with 5 lightslights

VB-9207.01 DC =

VB-9207.02 DC = Digital

VB-9207.03 DC = dig.Sound

VB-9207.04 AC ~ Digital

VB-9207.05 AC ~ dig.Sound

Digital version = with Power Pack

Sound version = with Dynamic Smoke and Power Pack





DE Belgische diesel 59 !

Wij brengen als model deze lok uit in al z'n varianten. 2 lichten, 3 lichten, 4 lichten en 5 lichten.

De lok is uitgerust met een centrale motor en dubbel vliegwiel, alle assen aangedreven
Mooie LED lichten en cabineverlichting en eventueel is het 3° koplicht ook schakelbaar

In digitaal bedrijf zijn de rode achterlichten apart schakelbaar

**Voor de digitale versies hebben de modellen een andere besturingsprint met een ge-integreerd Powerpack systeem.
(niet bij de analoge gelijkstroom versie)**



Die belgische Diesellok der Baureihe 59 !

Diese Lok kommt ausschließlich in allen varianten auf den Markt: Mit 2 Frontlampen, 3 Frontlampen, 4 Frontlampen und 5 Frontlampen.

Diese Lok ist mit einem zentral liegenden Motor wie auch doppelten Schwungmassen ausgestattet. Ein Antrieb erfolgt über alle Achsen, LED's ermöglichen eine Kabinenbeleuchtung, gegebenenfalls ist die dritte Frontlampe separat schaltbar.

Im Digitalbetrieb sind die roten Schlusslampen separat schaltbar.

**Für die digitalen Varianten ist eine Steuerplatine mit einem Powerpack-System eingebaut.
(Nicht in den analogen DC Varianten eingebaut)**

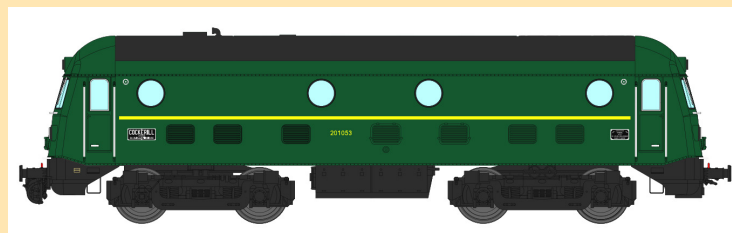
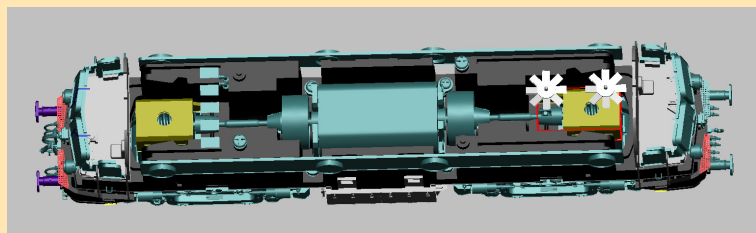

The Belgian Diesel Series 59 !

This Diesel locomotive comes exclusively in all variants on the market: with 2 front lamps, 3 front lamps, 4 front lamps and 5 front lamps. This locomotive is equipped with a centrally mounted engine as well as dual flywheels. Drives on all 6 axes, cabin lighting with LED, the third front lamp can be switched separately.

In digital mode the red rear lamps can be switched separately.

**For the digital versions a control board is fitted with a Power Pack system.
(Not in the analog DC variants installed)**



La locomotive Diesel de la série 59 !

Cette locomotive sortira dans toutes les variantes: Avec 2 phares, 3 phares, 4 phares et 5 phares.

Cette locomotive est équipée avec un moteur centralisé avec doubles volants d'inertie.

6 essieux garantissent un bon entraînement, éclairage de la cabine par LED, le troisième phare est commutable séparément.

En mode digital, les feux arrière rouges peuvent être commutable séparément.

**Les versions digitales sont équipées d' une platine de commande et d'un système Power Pack.
(Pas d'installation dans les variantes DC analogiques)**

.01	DC =		
.02	DC = Digital	.04	AC ~ Digital
.03	DC = dig.Sound	.05	AC ~ dig.Sound

Digital versions = with integrated Power Pack System

Artikel VB-9301 : Loc n° 5931 , Depot Haine St. Pierre

Ep. IV

 Diesel 59 geel met 4 frontlampen

 Diesel série 59, jaune, avec 4 phares.



UITVERKOCHT - EPUISE - SOLD OUT

 Diesellok der Baureihe 59, gelb, mit 4 Frontlampen.

 Diesel 59, yellow, with 4 headlamps.

Artikel VB-9302 : Loc n° 201.053 , Depot Merelbeke

Ep. III

 Diesel 59 groen met 3 frontlampen
6-cijferig nummer 201.053
met handreling onder het venster
nummer op front tussen dubbele gele frontlijnen.
Stelplaats : Merelbeke

 Diesel 59, vert, avec 3 phares
Numéro de 6 chiffres N°201.053.
Avec main courante sous la fenêtre.
Numéro à l'avant entre les lignes doubles
jaunes. Dépôt : Merelbeke.

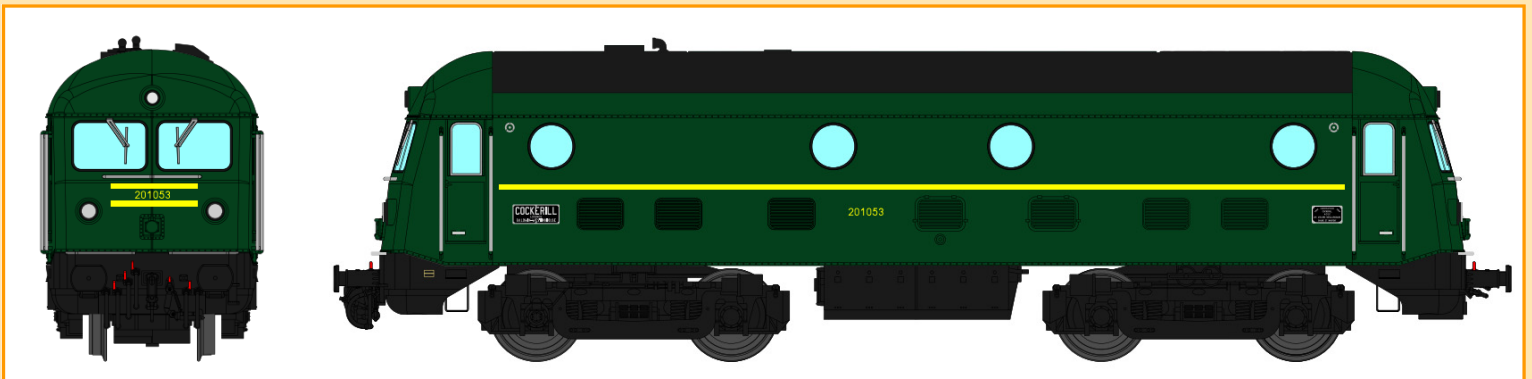

Deze tekeningen zijn enkel ter illustratie van het model

 Diesellok der Baureihe 59 in grüner Farbgebung mit 3 Frontlampen.
6 ziffrige Nummer N°201.053 mit dem B-Logo.
Mit Handlauf unter dem Fenster.
Nummer auf der Vorderseite zwischen den doppelten gelben Linien. BW : Merelbeke.

 Diesel 59, green, with 3 headlamps.
6 numbers N°201.053.
With handrail under the window.
Number on front between the double yellow lines. Depot : Merelbeke.

Artikel VB-9303 : Loc n° 5906 , Depot Merelbeke

Ep. IV

 Diesel 59 groen met **5 frontlampen**
4-cijferig nummer 5906
met handreling onder het venster
Stelplaats : Merelbeke

NEW 17

 Diesel série 59, verte, avec **5 phares.**
Numéro de 4 chiffres N°5906
Avec main courante sous la fenêtre.
Dépôt : Merelbeke.



Deze tekeningen zijn enkel ter illustratie van het model

 Diesellok der Baureihe 59 in grüner Farbgebung
mit **5 Frontlampen**
Mit Handlauf unter dem Fenster.
BW : Merelbeke.

 Diesel 59, green, with **5 headlamps.**
4 numbers N°5906
With handrail under the window.
Depot : Merelbeke.

Artikel VB-9304 : Loc n° 5936 , Depot Antwerpen Dam

Ep. IV

 Diesel 59 geel met **5 frontlampen**
4-cijferig nummer 5936 met B-logo
met handreling onder het venster
Stelplaats : Antwerpen Dam

NEW 17

 Diesel série 59, jaune, avec **5 phares.**
Numéro de 4 chiffres N°5936 avec logo B.
Avec main courante sous la fenêtre.
Dépôt : Antwerpen Dam.



Deze tekeningen zijn enkel ter illustratie van het model

 Diesellok der Baureihe 59, gelb, mit **5 Frontlampen.**
4 ziffrige Nummer N°5936 mit dem B-Logo.
Mit Handlauf unter dem Fenster.
BW : Antwerpen Dam.

 Diesel 59, yellow, with **5 headlamps.**
4 numbers N°5936 with B-logo.
With handrail under the window.
Depot : Antwerpen Dam.

NMBS - SNCB Diesel 62 : Artikel VB-9115

NEW 17



Loc nr 6215

Blauwe schildering
Dunne nummers
Stelplaats Kinkempois
Epoche IV

Lok N° 6215

Blaue Farbe
feine nummer
BW : Kinkempois
Epoche IV

Locomotive N° 6215

Livrée bleu
chiffres fines
Dépôt: Kinkempois
Epoque IV



VB-9115.01 DC =

VB-9115.02 DC = Digital

VB-9115.03 DC = dig.Sound

VB-9115.04 AC ~ Digital

VB-9115.05 AC ~ dig.Sound

NMBS - SNCB Diesel 75 : Artikel VB-9402

Loc nr 7503
Groene schildering
Met radionaam 'Olga'
Stelplaats Antwerpen Dam
Epoche IV

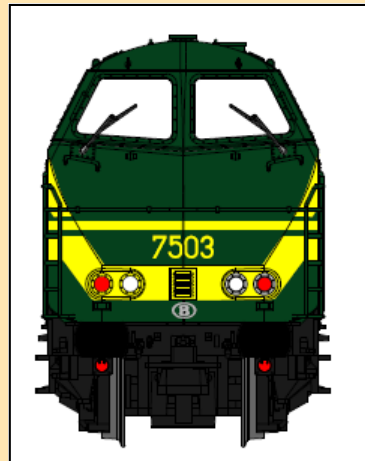

Locomotive N° 7503
Livrée verte
Numéro d'appel radio 'Olga'
Dépôt: Anvers
Epoque IV

Lokomotive N° 7503
Grüne Farbgebung
Radio Rufname 'Olga'
BW : Antwerpen Dam
Epoche IV

Locomotive N° 7503
Green livery
Radio call name 'Olga'
Depot : Antwerpen Dam
Era IV

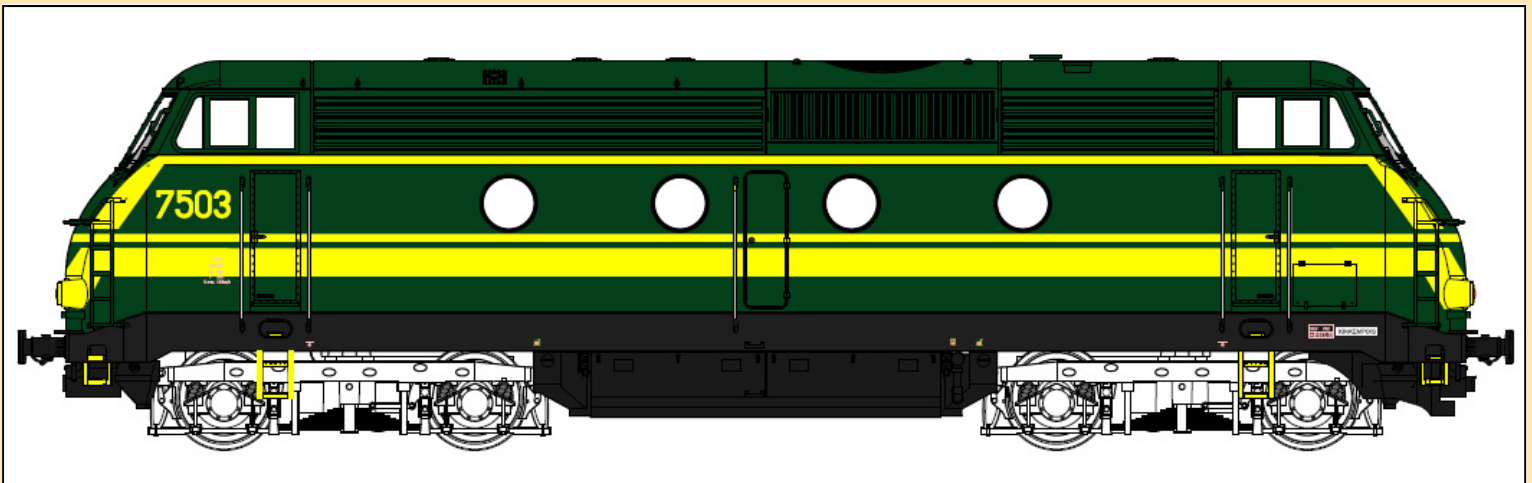

VB-9402.01 DC =
VB-9402.02 DC = Digital
VB-9402.03 DC = dig.Sound

VB-9402.04 AC ~ Digital
VB-9402.05 AC ~ dig.Sound

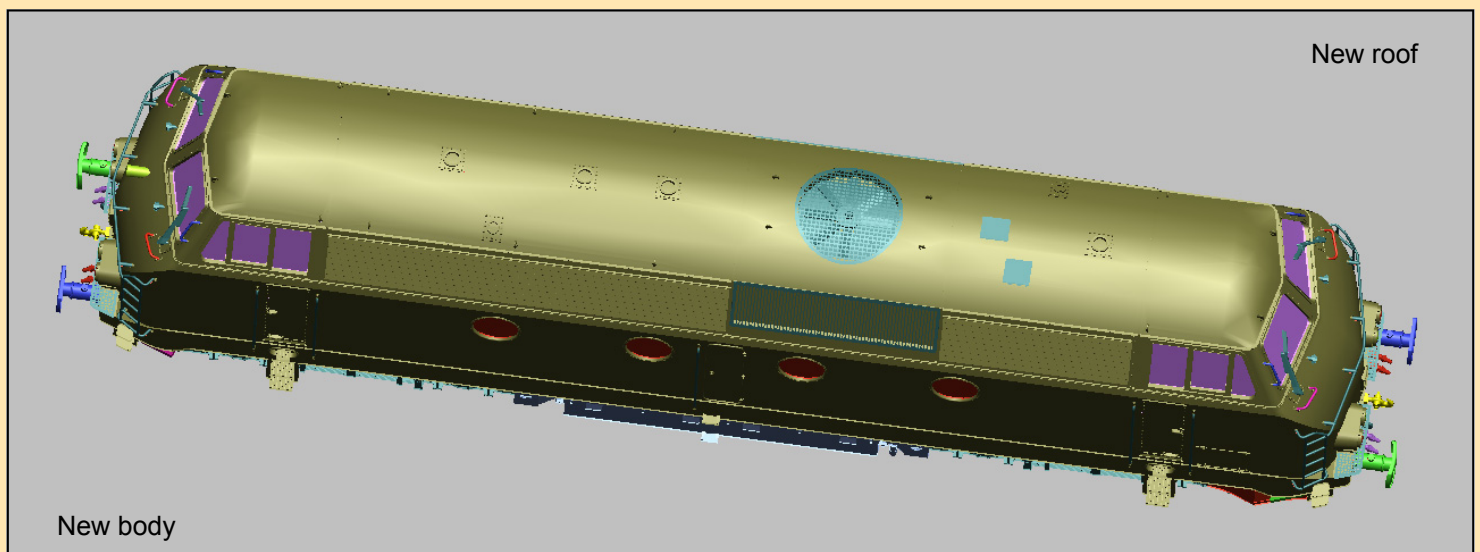

Diesel / rangeerlokje NMBS 90 - 91

The " BELGIUM BIG BOY " : with SOUND and Power Pack !

Model standaard uitgerust met LED verlichting
Wit/rode wisselende lichten
Fijne details en messing onderdelen
Alles bedrukt en scherpe belijning

Le modèle possède un éclairage intérieur LED de série.
Inversion des feux LED rouge/blanc de série.
Haute finition des détails, avec des pièces en laiton.
Complètement lettré avec des lignes très fines

AC versions only for Märklin C-rails !

The model has standard an interior LED lighting.
Light inversion LED red/white as standard.
Fine details with brass parts.
Completely labeled and fine sharp lines.

Das Modell verfügt als standard über eine LED
Beleuchtung.
Standard LED Lichtwechsel rot/weiss.
Feine Details, mit Messingteile.
Komplett bedrukt, mit scharf gezogenen Linien.

VB-5002 : industrie loc " CFI Group " loc n° 7



Prototype

Versies	system		Versions	system
VB-5002.01	DC		VB-5002.01	2-rail Courant Continu
VB-5002.02	DC digital		VB-5002.02	2-rail CC digital
VB-5002.03	DC digital SOUND		VB-5002.03	2-rail CC digital SON
VB-5002.04	AC dig (mfx)		VB-5002.04	AC dig (mfx)
VB-5002.05	AC dig (mfx) SOUND		VB-5002.05	AC dig (mfx) SON

Diesel / rangeerlokje NMBS 90 - 91

VB-5003 : Loc 9138 'Valère' : New Look versie , Oostende



Prototype



Versies	system		Versions	system
VB-5003.01	DC		VB-5003.01	2-rail Courant Continu
VB-5003.02	DC digital		VB-5003.02	2-rail CC digital
VB-5003.03	DC digital SOUND		VB-5003.03	2-rail CC digital SON
VB-5003.04	AC dig (mfx)		VB-5003.04	AC dig (mfx)
VB-5003.05	AC dig (mfx) SOUND		VB-5003.05	AC dig (mfx) SON

VB-5004 : Loc 230.008 Ep. III Ronet

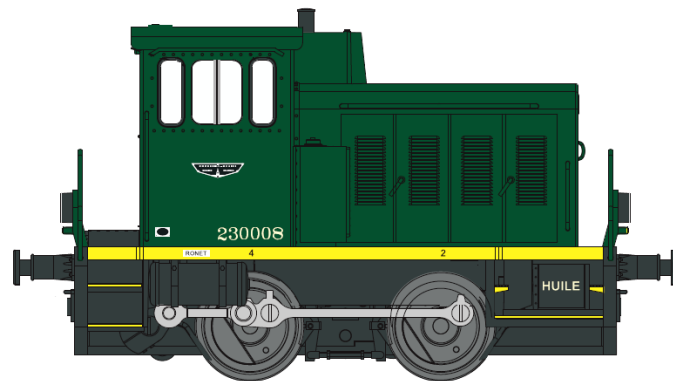
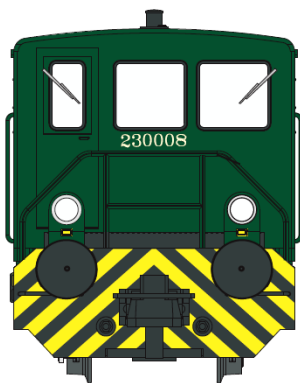

Versies	system		Versions	system
VB-5004.01	DC		VB-5004.01	2-rail Courant Continu
VB-5004.02	DC digital		VB-5004.02	2-rail CC digital
VB-5004.03	DC digital SOUND		VB-5004.03	2-rail CC digital SON
VB-5004.04	AC dig (mfx)		VB-5004.04	AC dig (mfx)
VB-5004.05	AC dig (mfx) SOUND		VB-5004.05	AC dig (mfx) SON



Komplett neue Produktion ! Basiert nicht auf den Mehano Modellen. Entwickelt mit den Originalplänen der Vossloh G2000. Neuer 21-poliger ESU-Dekoder V4-M4-Railcom + mit dem original aufgenommenen Sound der G2000.

Unser Modell der G2000 ist in: Gleichstrom, DC digital, DC digital Sound, AC Digital und AC-Digital-Sound Mfx

NEW 17

G 2000 Sweden : Hectorrail - Morricone

sofort lieferbar - disponible - leverbaar - available

3030.01	DC =		
3030.02	DC = Digital	3030.04	AC ~ Digital
3030.03	DC = dig.Sound	3030.05	AC ~ dig.Sound





Complete new production ! Not based on Mehano models. Developed with original plans of Vossloh G2000 New 21-pin ESU Sound decoder V4-M4-Railcom+ with original registered sound of the model

We deliver our models in : DC, DC digital, DC digital Sound , AC digital and AC digital Sound Mfx



 **Volledig nieuwe ontwikkeling - productie !** Niet op basis van de bestaande Mehano modellen.
Ontworpen op basis van de originele constructieplannen van Vossloh G2000
Nieuwe 21-pin ESU Sound decoder V4-M4-Railcom+ met eigen opgenomen sound van de echte loc.
Beschikbaar in alle versies : DC, DC digital, DC digital Sound , AC digital en AC digital Sound Mfx



Swiss loco G 2000 : Scheuchzer - Rhino 3

NEW 17

1° batch : sofort lieferbar - disponible - leverbaar - available

3031.01	DC =		
3031.02	DC = Digital	3031.04	AC ~ Digital
3031.03	DC = dig.Sound	3031.05	AC ~ dig.Sound



 Toute nouvelle production ! Développée avec des plans originaux de la Vossloh G2000.
Nouveau décodeur sonore 21-pin ESU V4-M4-Racom + avec le son original de la G2000.

Nos modèles seront disponibles en 2-rails, CC digital, CC digital son, CA digital et CA digital-son Mfx.



 **Volledig nieuwe ontwikkeling - productie !** Niet op basis van de bestaande Mehano modellen.
Ontworpen op basis van de originele constructieplannen van Vossloh G2000
Nieuwe 21-pin ESU Sound decoder V4-M4-Railcom+ met eigen opgenomen sound van de echte loc.
Beschikbaar in alle versies : DC, DC digital, DC digital Sound , AC digital en AC digital Sound Mfx

 **Komplett neue Produktion !** Basiert nicht auf den Mehano Modellen. Entwickelt mit den Originalplänen der Vossloh G2000. Neuer 21-poliger ESU-Dekoder V4-M4-Railcom + mit dem original aufgenommenen Sound der G2000.
Unser Modell der G2000 ist in: Gleichstrom, DC digital, DC digital Sound, AC Digital und AC-Digital-Sound Mfx

G 2000 HUPAC

NEW 17



3032.01 DC =
3032.02 DC = digital
3032.03 DC = digit.Sound

3032.04 AC ~ digital
3032.05 AC ~ digit.Sound

 **Complete new production !** Not based on Mehano models. Developped with original plans of Vossloh G2000
New 21-pin ESU Sound decoder V4-M4-Railcom+ with original registered sound of the model

We deliver our models in : DC, DC digital, DC digital Sound , AC digital and AC digital Sound Mfx

 **Toute nouvelle production !** Développée avec des plans originaux de la Vossloh G2000.
Nouveau décodeur sonore 21-pin ESU V4-M4-Racom + avec le son original de la G2000.

Nos modèles seront disponibles en 2-rails, CC digital, CC digital son, CA digital et CA digital-son Mfx.

Colas Rail 203

Limited Serie !

NEW 17



3033.01 DC =
3033.02 DC = digital
3033.03 DC = digit.Sound

3033.04 AC ~ digital
3033.05 AC ~ digit.Sound

G2000 DB Schenker Rail Italia

NEW 17



3034.01 DC =
3034.02 DC = digital
3034.03 DC = digit.Sound

3034.04 AC ~ digital
3034.05 AC ~ digit.Sound



Special Edition : Nürnberg Messe Loc 2017

BL-2017.01 DC =
BL-2017.02 DC = digital
BL-2017.03 DC = digit.Sound
BL-2017.04 AC ~ digital
BL-2017.05 AC ~ digit.Sound



NMBS E-Loc reeks 22 - SNCB E-loc série 22

Neu in unserem Programm für das Jahr 2017 ist die belgische E-Lok der Baureihe 22. Aussergewöhnlich an dieser Baureihe ist, dass die Lüftergitter an der Seite des Dachs verbaut sind.

All diese Modelle sind sehr fein mit vielen Details verarbeitet. Alle Griffe sind lose Teile die separat montiert werden, die meisten bestehen aus Metall.

Die Scheibenwischer werden in filigran montiert, und sind nicht mehr gegossen. Das Drehgestell besteht aus mehreren Einzelteilen und nicht aus einem einzigen Gussstück, auch das Innenleben der Kabine beinhaltet viele Details.

Die E-Lok mit der Betriebsnummer 2237 soll im Neujahr 2017 lieferbar sein.

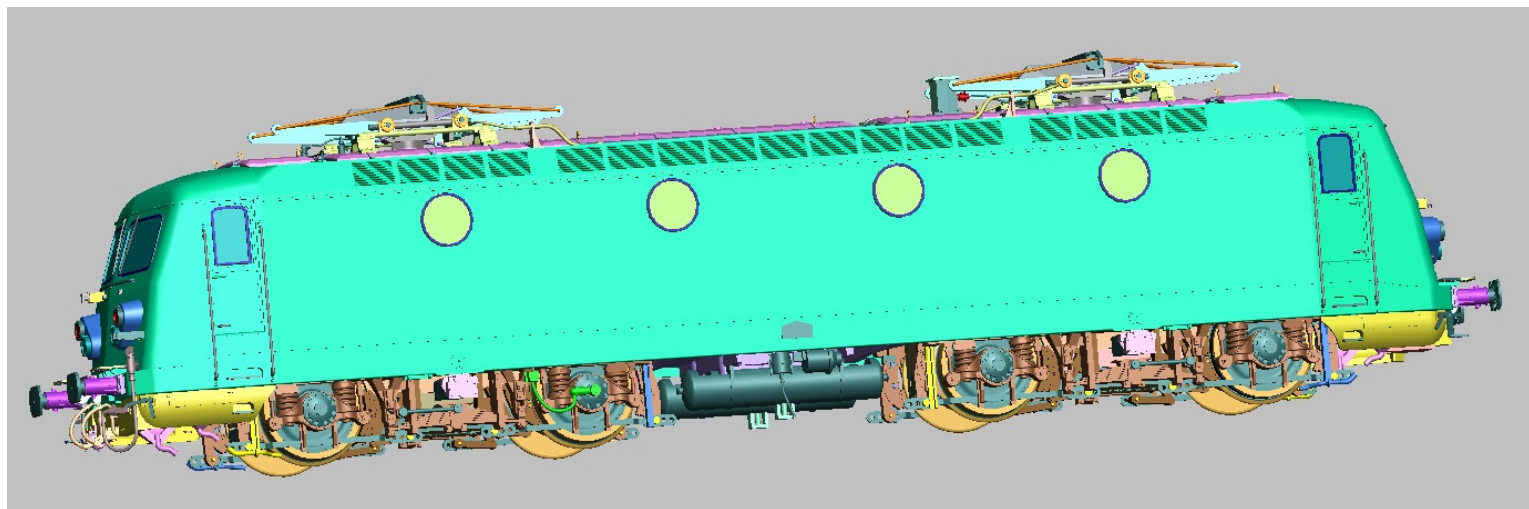

3D tekeningen E-loc 22

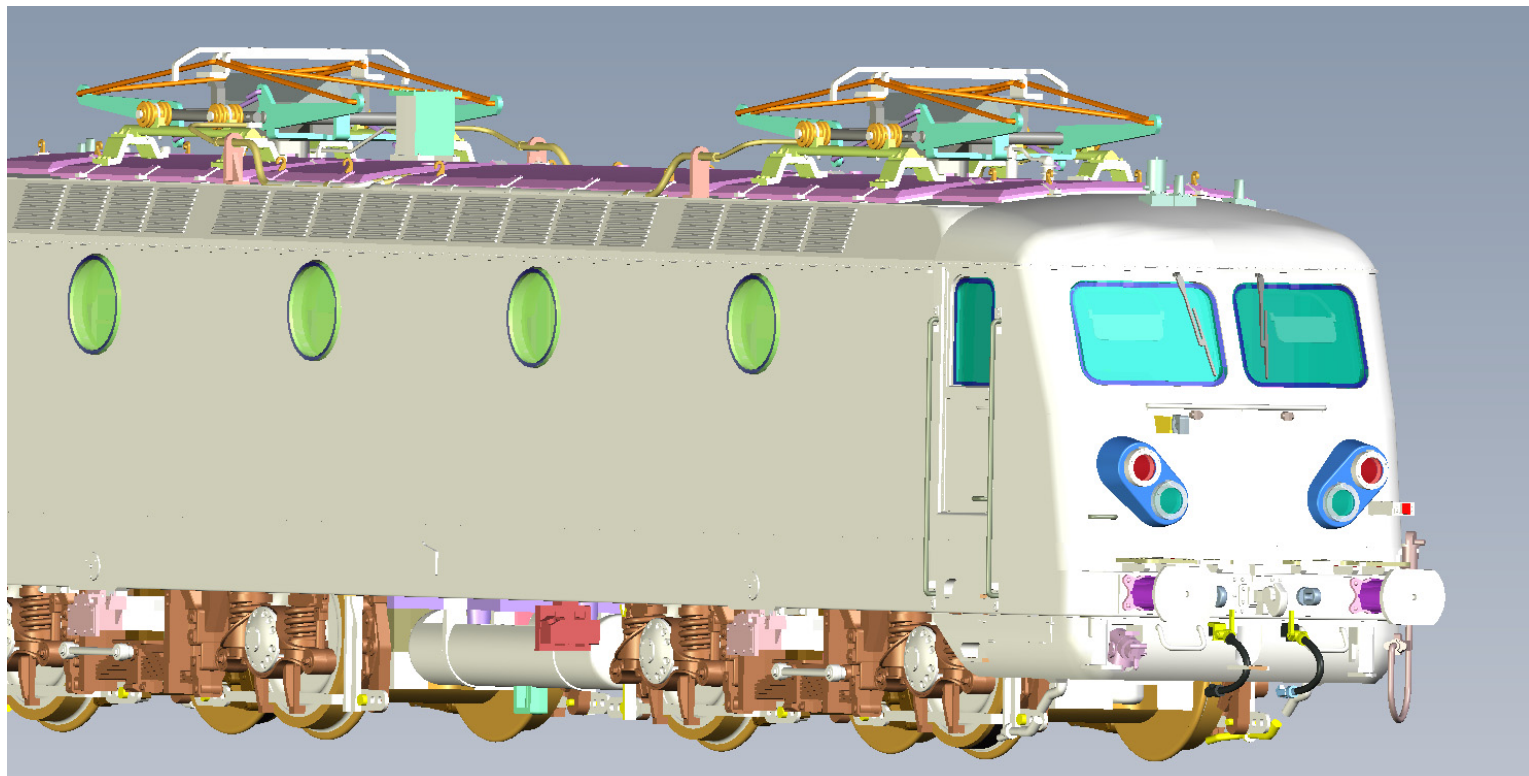

NMBS E-Loc reeks 22 - SNCB E-loc série 22

Nouveau dans notre programme pour l'année 2017, est la locomotive électrique SNCB de la série 22. Exceptionnellement dans cette série est, que les grilles de ventilation sont installés sur le côté du toit.

Tous ces modèles sont d'une haute finition et équipés avec de nombreux détails. Toutes les poignées sont des pièces détachées qui ont été assemblés séparément, la plupart d'elles sont en métal.

Les essuie-glaces sont montés en filigrane, et non coulés en métal. Le bogie est constitué de plusieurs pièces individuelles et non d'une seule pièce coulée, l'intérieur de la cabine est également équipé de nombreux détails.

La locomotive électrique avec le numéro 2237 sera disponible début de l' année 2017.

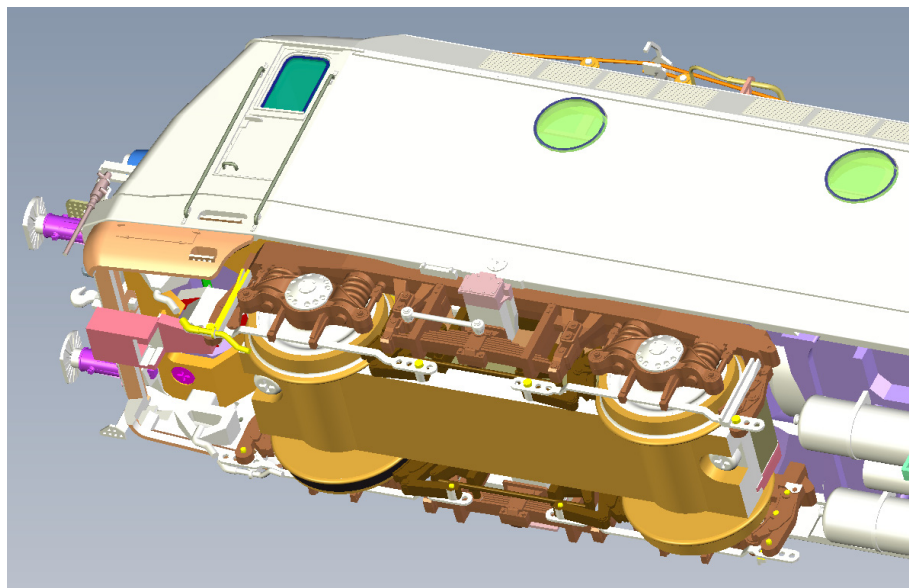
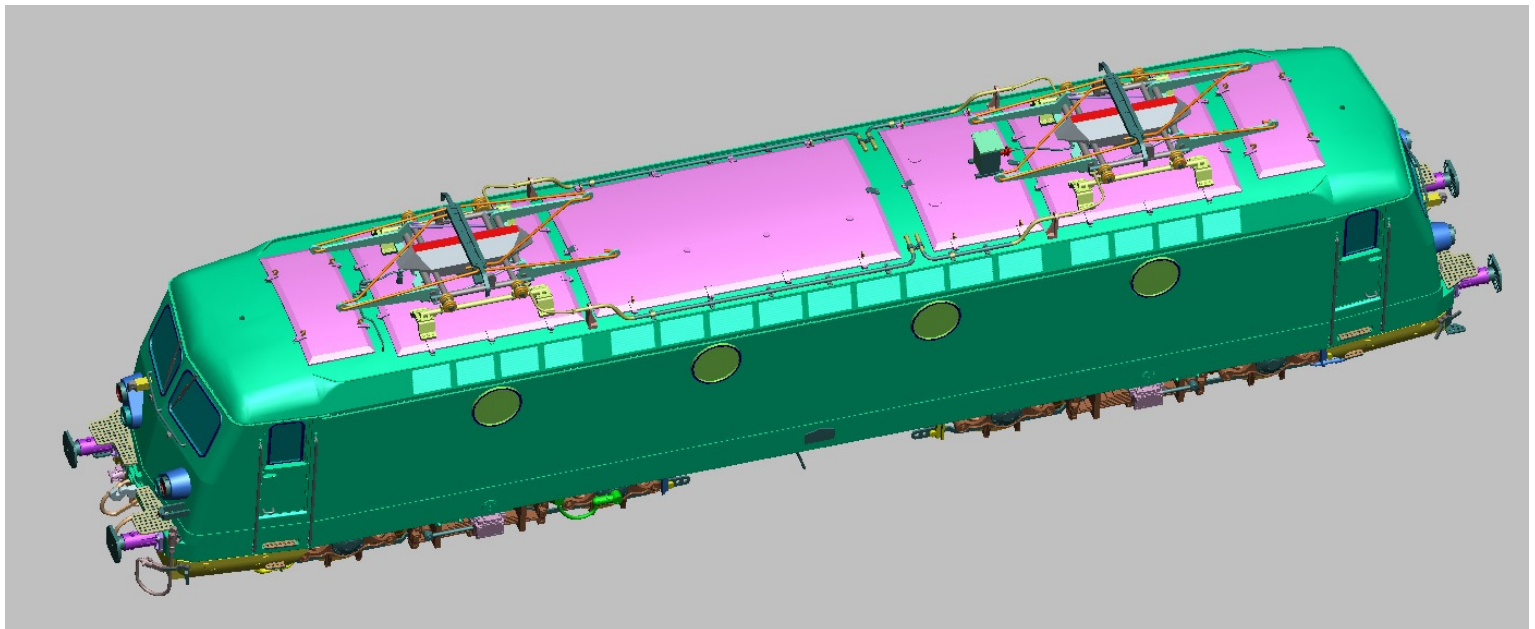

NMBS E-Loc reeks 22 - SNCB E-loc série 22

Nieuw in ons gamma voor 2017 is de Belgische E-loc reeks 22.
Speciaal aan deze reeks is dat de roosters verwerkt zitten in de zijkant van het dak.

Al deze modellen zijn zeer fijn afgewerkt met oog voor vele details.
Alle handgrepen zijn losse stukjes die er apart worden op gemonteerd, de meeste zelfs in metaal.
De ruitenwissers worden in filigraan gemonteerd, ze zijn niet meegegoten.

De bougie bestaat uit verschillende losse elementen en niet uit 1 gietstuk, ook het interieur van de cabine is tot in detail afgewerkt .

Tegen het najaar van 2017 brengen we dan de groene loc 2237 uit.

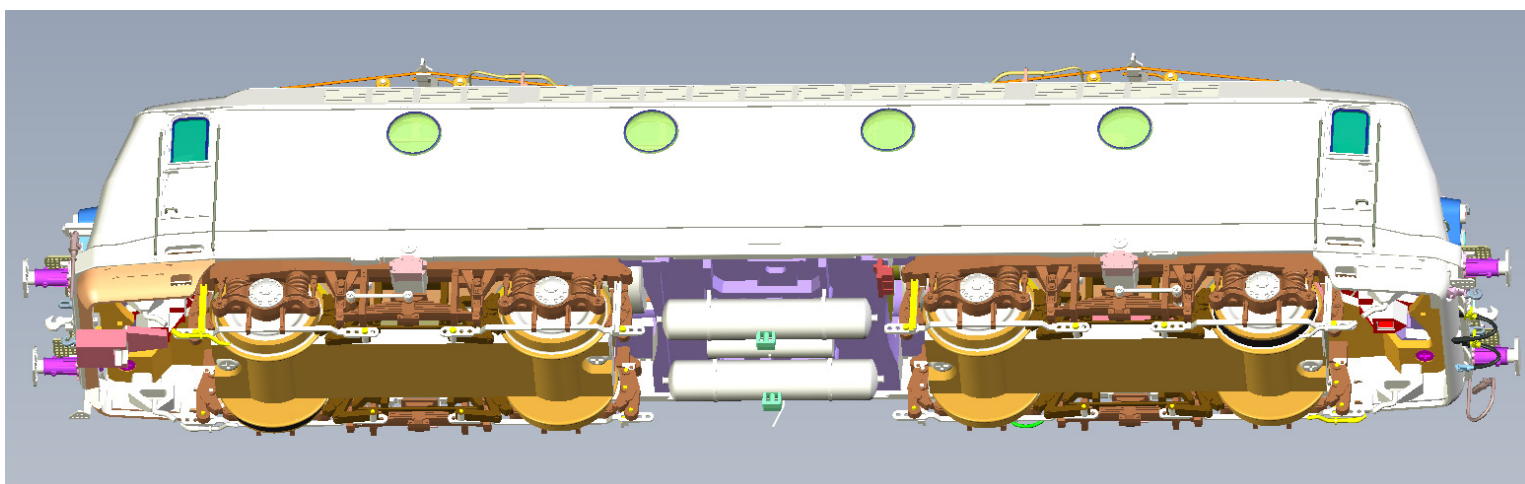

Zeer fijn gedetailleerd model met enorm veel gemonteerde stukjes. Modellen afgewerkt tot in de kleine details

Eind februari verwachten we al het eerste prototype, we plaatsen dan hier de foto's van dit model

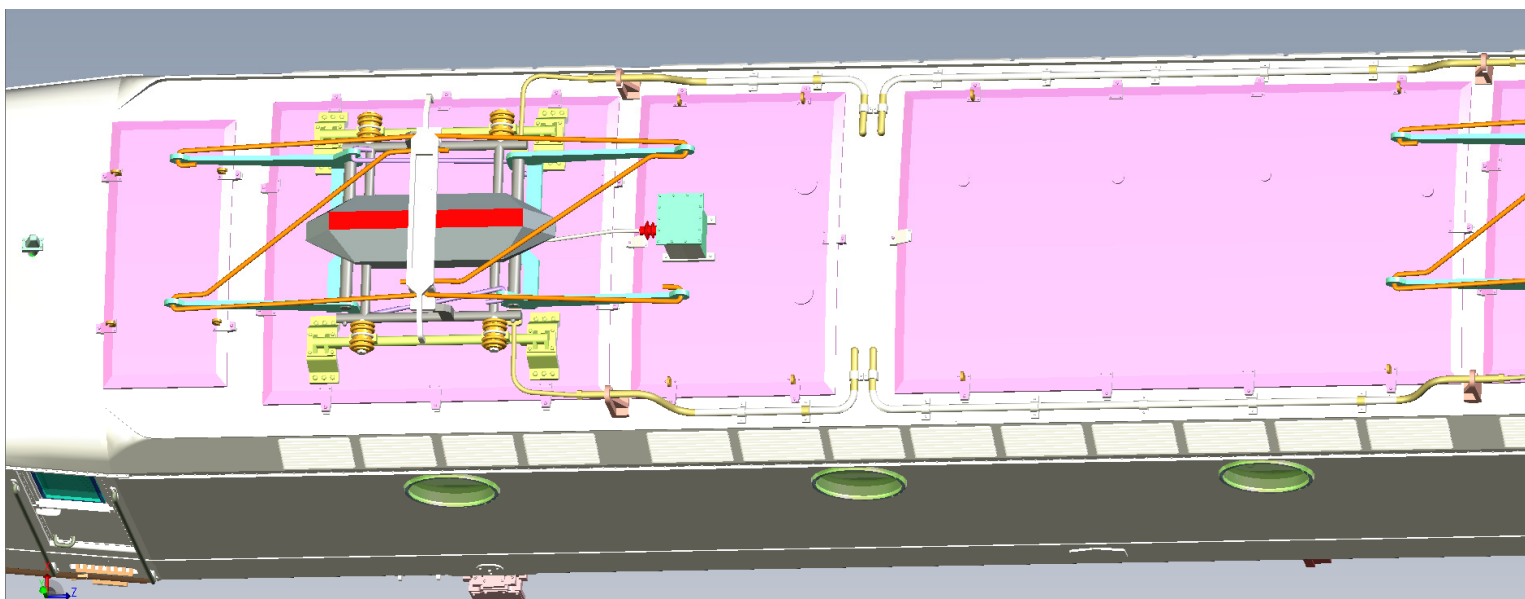

E-loc reeks 22 :

Order nr : VB-3301 E-loc 2237

VB-3301 : Loc 2237

- Groen
- 4 lichten
- geen telecomkabel
- oude koplampen
- met fabrieksplaat

Tijdperk IV
Stelplaats : Merelbeke

VB-3301 : Loc 2237

- Vert
- 4 phares
- sans câblot télécom
- vieux phares
- avec plaque d'usine

Epoche IV
Dépot : Merelbeke

Version			Versie		
VB-3301.02	<i>pour Märklin*</i>	CA Digital Mfx	VB-3301.02	<i>voor Märklin*</i>	AC Digitaal Mfx
VB-3301.04	“	CA Digital SOUND Mfx	VB-3301.04	“	AC Dig.SOUND Mfx

VB-3301.05	<i>2-Rails = CC</i>	Courant continu	VB-3301.05	<i>Gelijkstroom DC</i>	conventioneel
VB-3301.06	“	Courant continu digital	VB-3301.06	“	Digitaal
VB-3301.07	“	CC digital SOUND	VB-3301.07	“	Digitaal Sound

Order nr : VB-3009 E-loc 2335



Loc 2335
 Groen
 Met verbindingskabel
 Witte `V` op front
 Stelplaats Ronet
 Epoche IV

Loc 2335
 Grün
 Mit Verbindungskabeln
 Mit weißem `V` auf der
 Frontseite BW : Ronet
 Epoche IV

Loc 2335
 Vert , avec les câbles
 de connexion
 `V` Blanc sur le nez
 Dépôt : Ronet
 Epoche IV

NEW 17



Version			Versie		
VB-3009.02	<i>pour Märklin*</i>	CA Digital Mfx	VB-3009.02	<i>voor Märklin*</i>	AC Digitaal Mfx
VB-3009.04	“	CA Digital SOUND Mfx	VB-3009.04	“	AC Dig.SOUND Mfx

VB-3009.05	<i>2-Rails = CC</i>	Courant continu	VB-3009.05	<i>Gelijkstroom DC</i>	conventioneel
VB-3009.06	“	Courant continu digital	VB-3009.06	“	Digitaal
VB-3009.07	“	CC digital SOUND	VB-3009.07	“	Digitaal Sound

Order nr : VB-3010 E-loc 2343

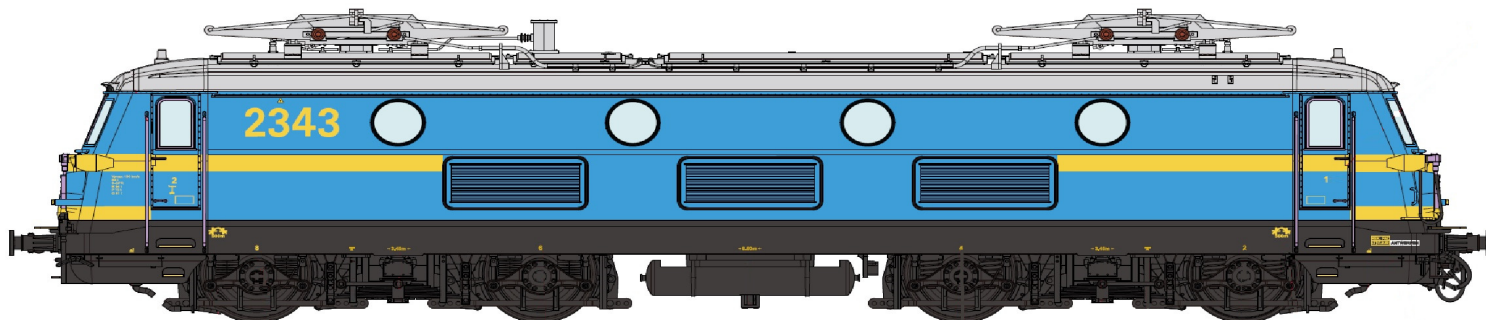

Loc 2343

Blauw
Met verbindingkabel
Met Telecom kabel
Stelplaats Antwerpen
Tijdperk VI

Loc 2343

Blau.
Mit Verbindungskabeln.
Mit Telecom Kabel.
BW : Antwerpen
Epoche VI

Loc 2343

Bleue
Avec les câbles de connexion.
Avec les câbles Telecom.
Dépôt : Anvers
Epoque VI

Version			Versie		
VB-3010.02	<i>pour Märklin*</i>	CA Digital Mfx	VB-3010.02	<i>voor Märklin*</i>	AC Digitaal Mfx
VB-3010.04	“	CA Digital SOUND Mfx	VB-3010.04	“	AC Dig.SOUND Mfx

VB-3010.05	<i>2-Rails = CC</i>	Courant continu	VB-3010.05	<i>Gelijkstroom DC</i>	conventioneel
VB-3010.06	“	Courant continu digital	VB-3010.06	“	Digitaal
VB-3010.07	“	CC digital SOUND	VB-3010.07	“	Digitaal Sound

Order nr : VB-3203 E-loc 2510



NEW 17

Loc 2510
 Groen
 Geen kabels
 zilveren V op front
 Stelplaats Brussel Zuid
 Epoche IV

Loc 2510
 Grün
 Ohne kabeln
 Mit V auf der Frontseite BW : Brussel Zuid
 Epoche IV

Loc 2510
 Vert
 sans câbles
 V sur le nez
 Dépôt : Bruxelles Midi
 Epoche IV

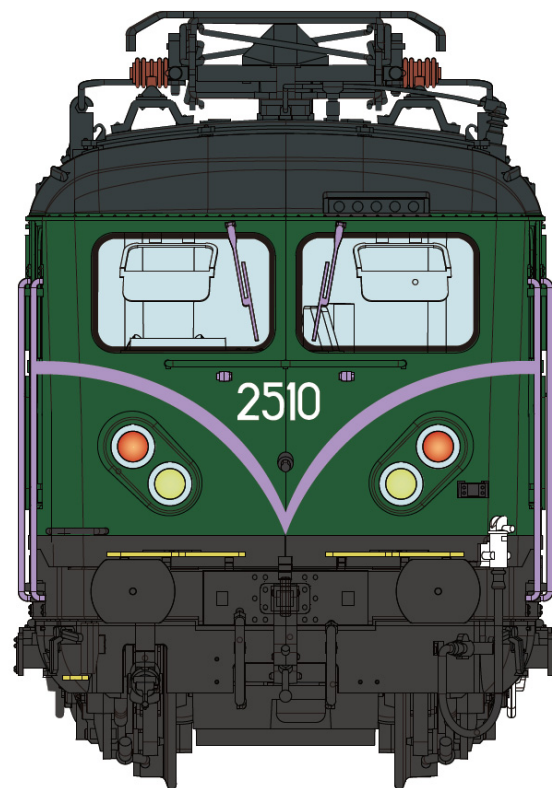

Version			Versie		
VB-3203.02	<i>pour Märklin*</i>	CA Digital Mfx	VB-3203.02	<i>voor Märklin*</i>	AC Digitaal Mfx
VB-3203.04	“	CA Digital SOUND Mfx	VB-3203.04	“	AC Dig.SOUND Mfx

VB-3203.05	<i>2-Rails = CC</i>	Courant continu	VB-3203.05	<i>Gelijkstroom DC</i>	conventioneel
VB-3203.06	“	Courant continu digital	VB-3203.06	“	Digitaal
VB-3203.07	“	CC digital SOUND	VB-3203.07	“	Digitaal Sound

Order nr : VB-3204 E-loc 2514

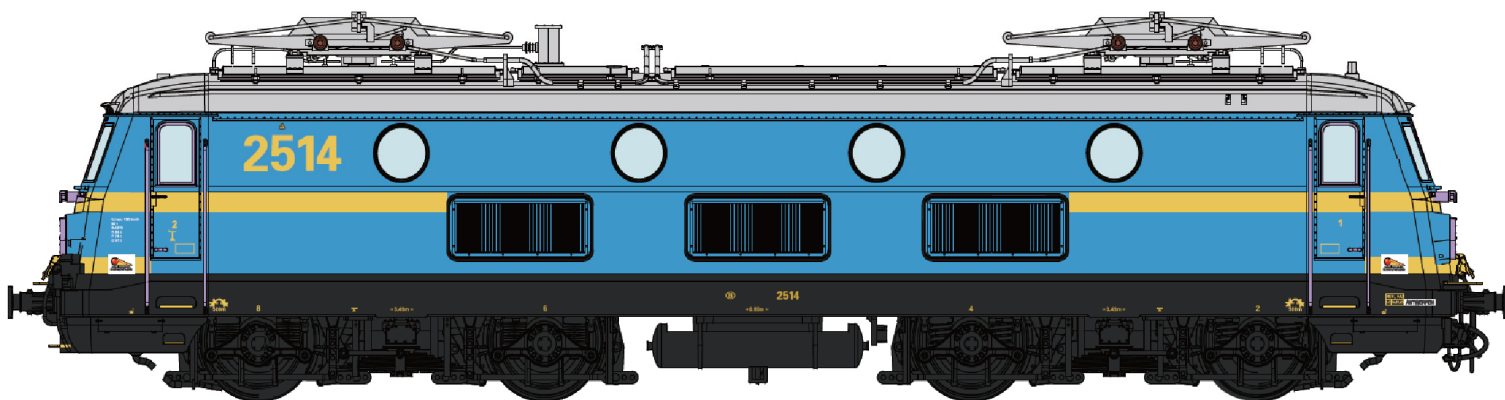

NEW 17



Loc 2514

Blauw
Met verbindingskabel
Met Telecom kabel
Stelplaats Antwerpen
Tijdperk VI

Loc 2514

Blau.
Mit Verbindungskabeln.
Mit Telecom Kabel.
BW : Antwerpen
Epoche VI

Loc 2514

Bleue
Avec les câbles de connexion.
Avec les câbles Telecom.
Dépôt : Anvers
Epoque VI

Version			Versie		
VB-3204.02	<i>pour Märklin*</i>	CA Digital Mfx	VB-3204.02	<i>voor Märklin*</i>	AC Digitaal Mfx
VB-3204.04	“	CA Digital SOUND Mfx	VB-3204.04	“	AC Dig.SOUND Mfx

VB-3204.05	<i>2-Rails = CC</i>	Courant continu	VB-3204.05	<i>Gelijkstroom DC</i>	conventioneel
VB-3204.06	“	Courant continu digital	VB-3204.06	“	Digitaal
VB-3204.07	“	CC digital SOUND	VB-3204.07	“	Digitaal Sound

Order nr : VB-3103 E-loc 2557

Benelux E-loc reeks 25.5 :



VB-3103 : Loc 2557



VB-3103 : Loc 2557

- Blauw met onderbroken gele band
- telecom- en trekduwkabel
- horizontale lamellen
- locnummer en B-logo op zijkant
- geen fabrieksplaat
- Magelan logo

- Bleue avec ligne jaune.
- avec câblot télécom
- lamelles horizontales
- n° et B-logo sur le coté
- pas de plaque d'usine
- logo Magelan

Stelplaats : ANTWERPEN Tijdperk VI

Dépot : ANTWERPEN Epoche VI

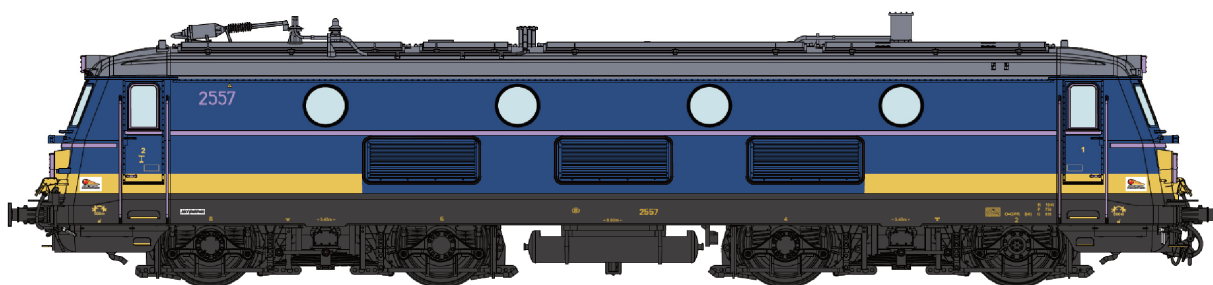

Version			Versie		
VB-3103.02	<i>pour Märklin*</i>	CA Digital Mfx	VB-3103.02	<i>voor Märklin*</i>	AC Digitaal Mfx
VB-3103.04	“	CA Digital SOUND Mfx	VB-3103.04	“	AC Dig.SOUND Mfx

VB-3103.05	<i>2-Rails = CC</i>	Courant continu	VB-3103.05	<i>Gelijkstroom DC</i>	conventioneel
VB-3103.06	“	Courant continu digital	VB-3103.06	“	Digitaal
VB-3103.07	“	CC digital SOUND	VB-3103.07	“	Digitaal Sound

Wagen

-

Wagons

-

Cars

Wagen Eaos-x 075 :

Dieses Modell besitzt nur eine Tür auf der Seite, und wurde noch nie als Modell produziert.
Diese Wagons sind viel auf dem Schienennetz verbreitet.

47.700 Set mit 2 wagons Eaos-x 075
DB Schenker + Beladung
'altem Eisen und alten Röhren'

47.701 wie 47.700, mit verschiedene
Wagennummern



47.702 Set mit 2 wagons Eaos-x 075
Railion + Beladung
'altem Eisen und und groben Rohren'

47.703 wie 47.702, mit verschiedene
Wagennummern



47.704 : Set mit 2 wagons Eaos-x 075 Railion Logistics + Beladung 'altem Eisen'
: Box with 2 cars Eaos-x 075 Railion Logistics, loaded with 'old metal scrap'

47.705 : like 47.704 but with other carnumbers / wie 47.704, mit verschiedene Wagennummern



Wagen Eaos-x 075 :

Dit model heeft slechts 1 deur aan de zijkant en is nog nooit in model uitgebracht.
Deze wagens zien we ook veel rijden op het Belgische spoor.

47.706 : Set mit 2 wagens Eaos-x 075 Railion Logistics + Beladung ' Eisenbahnschrott '
: Box with 2 cars Eaos-x 075 Railion Logistics , loaded with 'old train metal scrap'

47.707 : like 47.706 but with other carnumbers / wie 47.706, mit verschiedene Wagennummern



47.750 Set mit 2 wagens Eaos-x 051 DB
+ Beladung ' alten Steinen '

47.751 wie 47.750, mit verschiedene
Wagennummern



47.752 Set mit 2 wagens Eaos-x 051 DB
+ Beladung gepressten
Aluminiumblöcken

47.753 wie 47.752, mit verschiedene
Wagennummern

Containercar Sgns with tank container



De containerwagen type Sgns die B-Models al jaren in haar programma heeft is nu ook beschikbaar met tankcontainers. Elk artikelnummer bestaat uit één wagen met daarop twee 20ft tankcontainers. We streven ernaar om steeds realistische combinaties samen te stellen.



The container car type Sgns that has been in the B-Models collection for years is now also available with tank containers. Each reference number has one car loaded with two 20ft tank containers. We strive to compose realistic combinations.





Der Containerwagen vom Typ Sgns den es schon seit Jahren im B-Models Katalog gibt, ist jetzt auch mit Tankcontainern erhältlich. Jede Artikelnummer besteht aus einem Wagen, beladen mit zwei 20ft Tankcontainern. Wir versuchen immer realistische Kombinationen zusammen zu stellen.

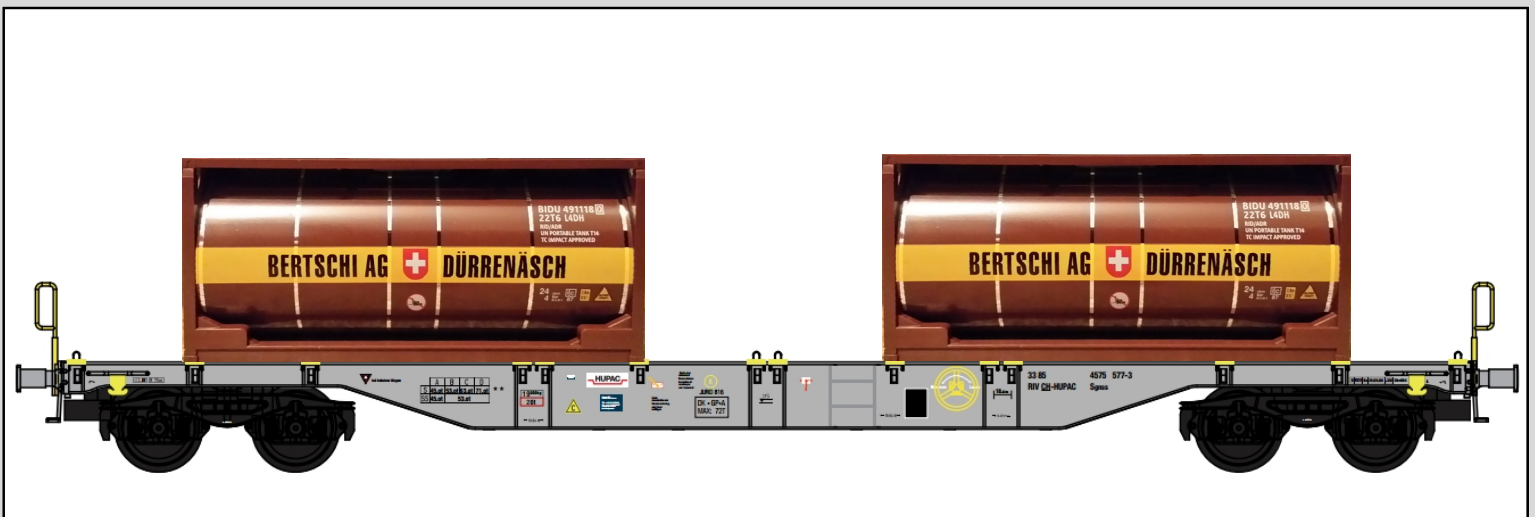

Le wagon container du type Sgns existant depuis des années dans la gamme B-Models, est maintenant disponible avec des conteneurs-citernes. Chaque numéro d'article se compose d'un wagon chargé avec deux conteneurs-citernes de 20ft (pieds). B-Models vous donne la possibilité avec sa gamme de pouvoir créer des trains de marchandise réels.



 54.100 - Hupac, grijs met Hupac logo, CH-HUPAC, beladen met 2x 20ft tankcontainer Bertschi





 54.100 - Hupac, grau mit Hupac logo, CH-HUPAC, beladen mit 2x 20ft Tankcontainer Bertschi

 54.100 - Hupac, grey with Hupac logo, CH-HUPAC, loaded with 2x 20ft tank container Bertschi

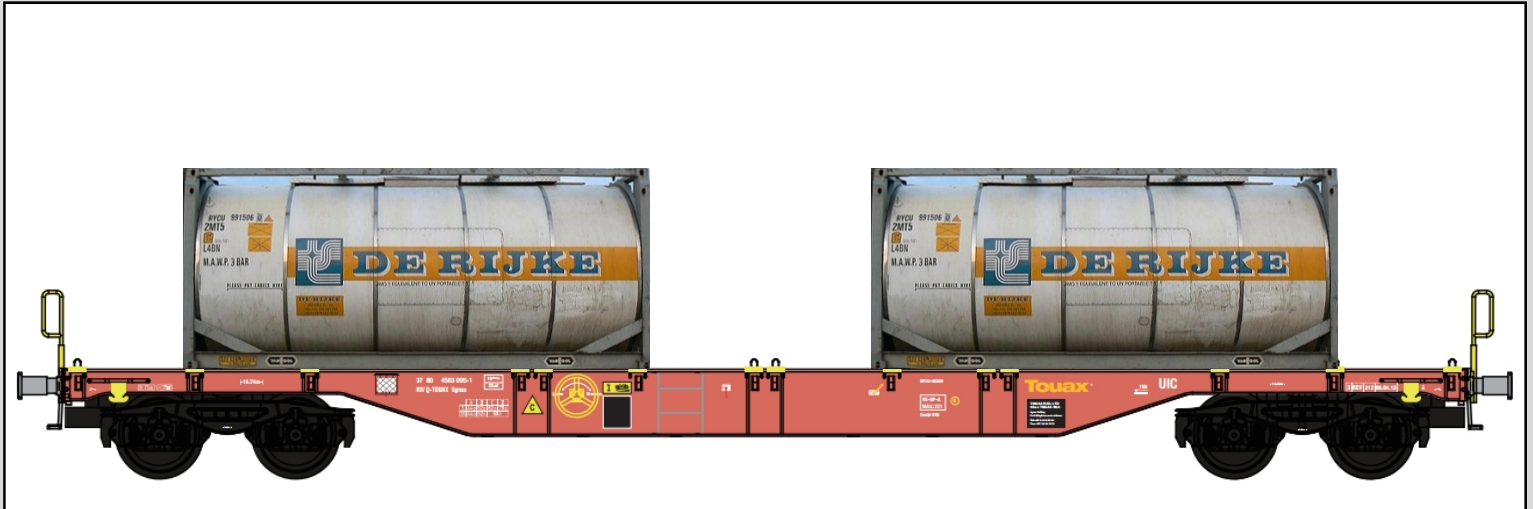



 54.100 - Hupac, gris avec logo Hupac, CH-HUPAC, chargé avec 2x 20ft conteneur citerne Bertschi

Containercar Sgns with tank container

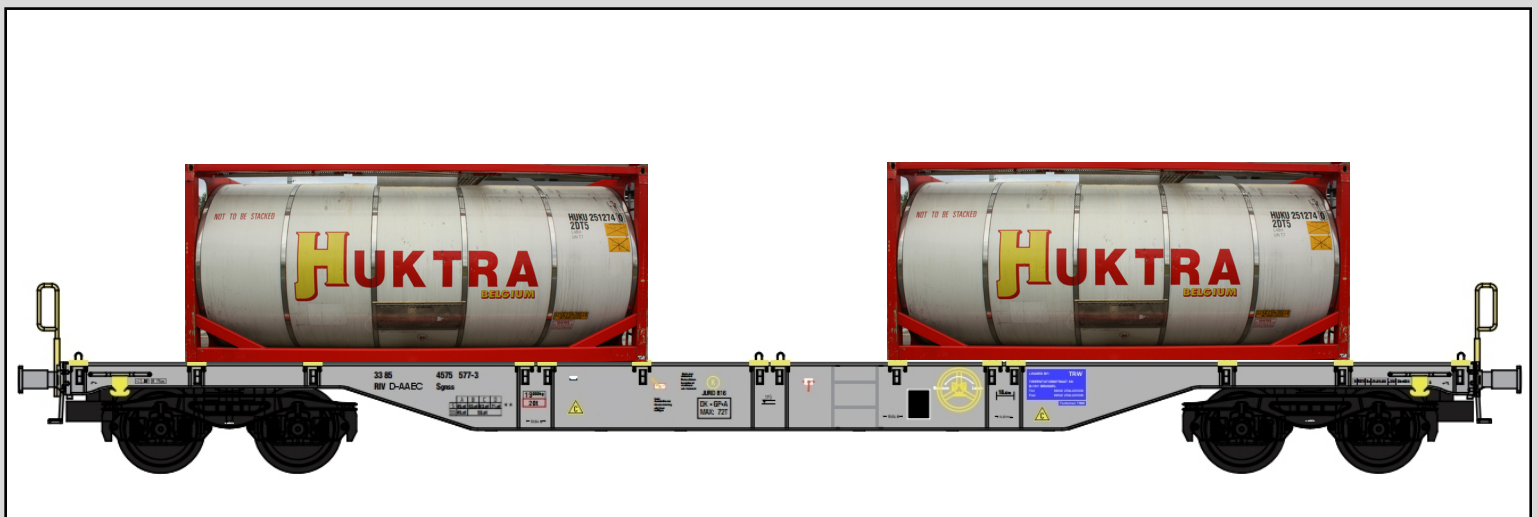

-  54.101 - Touax, rood, D-TOUAX, beladen met 2x 20ft tank container De Rijke
-  54.101 - Touax, rot, D-TOUAX, beladen mit 2x 20ft Tankcontainer De Rijke
-  54.101 - Touax, red, D-TOUAX, loaded with 2x 20ft tank container De Rijke
-  54.101 - Touax, rouge, D-TOUAX, chargé avec 2x 20ft conteneur citerne De Rijke



-  54.102 - AAE Cargo, verhuurd aan TRW, grijs, D-AAEC, beladen met 2x 20ft tank container Huktra
-  54.102 - AAE Cargo, vermietet an TRW, grau, D-AAEC, beladen mit 2x 20ft Tankcontainer Huktra
-  54.102 - AAE Cargo, rented out to TRW, grey, D-AAEC, loaded with 2x 20ft tank container Huktra
-  54.102 - AAE Cargo, loué a TRW, gris, D-AAEC, chargé avec 2x 20ft conteneur citerne Huktra

Ref. 45.134

Grey - set of 2 cars with 20ft MSC containers

D-AAEC - Sogemar Milano



Now available in the shops

Ref. 45.133

NMBS / SNCB bruin ICF





Ref. 45.135

Grau - Set 2 wagens mit 30ft Bulkhaul containers

AAE ICF Basel



Ref. 45.138

SBB Cargo loaded with containers

CH-SBB

Ref. 45.137

D-Touax mit 30ft containers : Van den Bosch

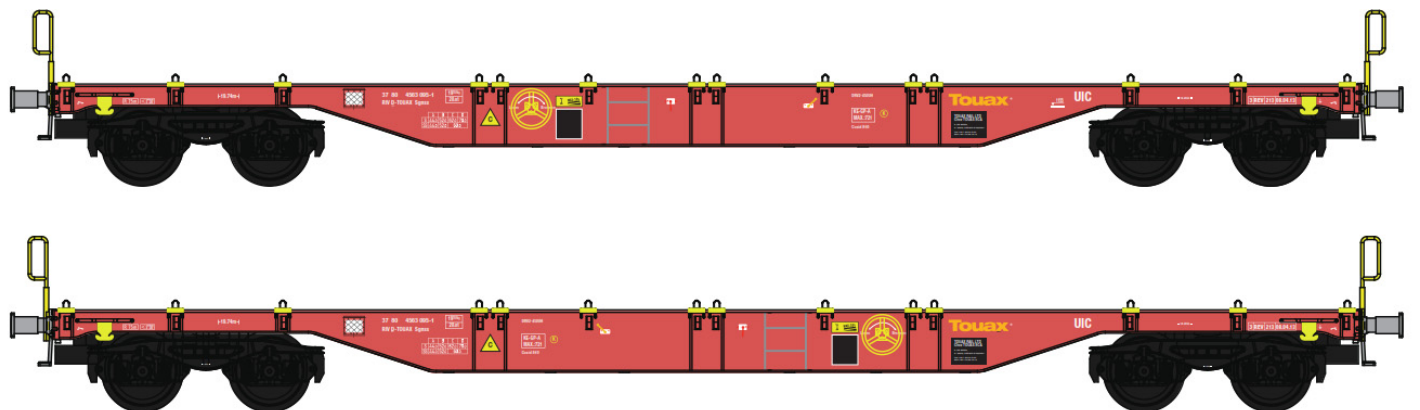



Ref. 45.136 CH-HUPAC mit containers : 40ft CAI + 20ft PIL / 20ft Gold + Hanjin + Sloman Neptun



Ref. 45.140 D-AAEC with 30ft containers : Bertschi AG DÜRRENÄSCH



45.218 - Set A : 2 erts-wagons 'ARBED Belval'

CFL

Ep. IV

45.219 - Set B : zoals set A maar met andere wagonnummers



45.220 - Set A : 2 erts-wagons 'COCKERILL SAMBRE' NMBS / SNCB

Ep. IV

45.221 - Set B : zoals set A maar met andere wagonnummers



45.222 - Set A : 2 erts-wagons 'COCKERILL SAMBRE' NMBS / SNCB

Ep. V

45.223 - Set B : zoals set A maar met andere wagonnummers





Der bekannte Getreidewagen von B-Models ist der einzige der auch in Miniatur die an der Seite typischen Schweißnähte besitzt. Beide Packungen A und B gibt es mit vier unterschiedlichen Betriebsnummern.



Le célèbre wagon céréalier de B-Models est le seul modèle qui possède les soudures typiques sur les côtés. Les coffrets A et B existent avec quatre numéros de wagons différentes.

45.318 - Set A : 2 wagons 'Polybulk' NMBS / SNCB

Ep. IV

45.319 - Set B : zoals set A maar met andere wagonnummers

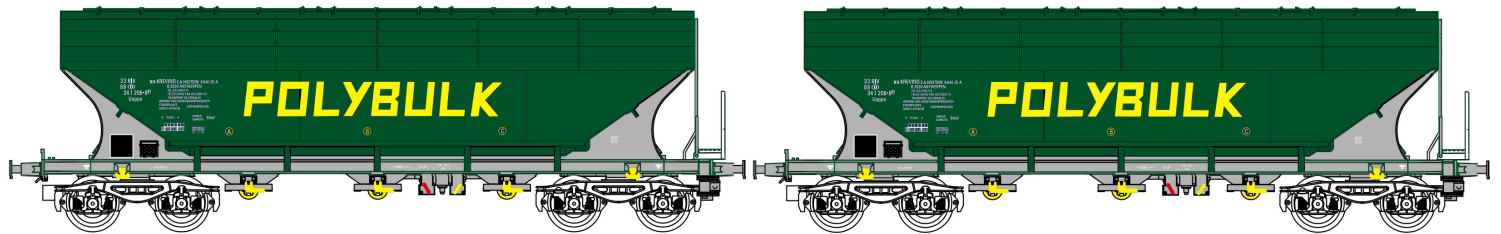

45.320 - Set A : Set mit 2 Silowagens 'NACCO' DB

Ep. V-VI

45.321 - Set B : wie set A aber mit neuen Betriebsnummern

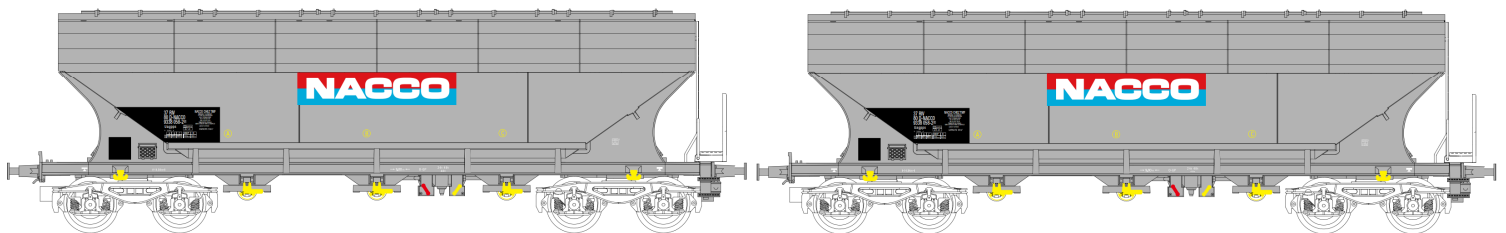

45.328 - Set A : Coffret de 2 wagons céréaliers 'TMF-Cita' noir SNCF

Ep. IV

45.329 - Set B : comme coffret A mais avec autres numéros d'immatriculation

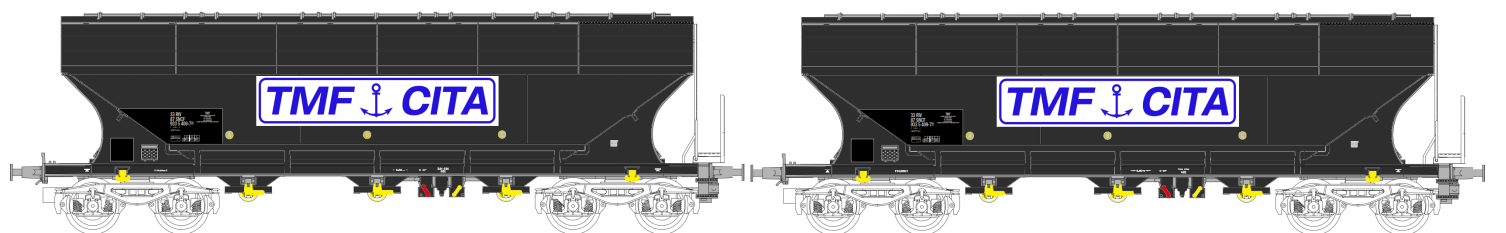



De gekende graanwagen waarbij B-models de enige is die in miniatuur de typische lasnaden heeft aan de zijkant
Telkens set A en B : met 4 verschillende wagnummers



Der bekannte Getreidewagen von B-Models ist der einzige der auch in Miniatur die an der Seite typischen Schweißnähte besitzt. Beide Packungen A und B gibt es mit vier unterschiedlichen Betriebsnummern.

45.330 - Set A : Coffret de 2 wagons céréaliers ' GUYOMARC'H ' SNCF

Ep. IV

45.331 - Set B : comme coffret A mais avec autres numéros d'immatriculation

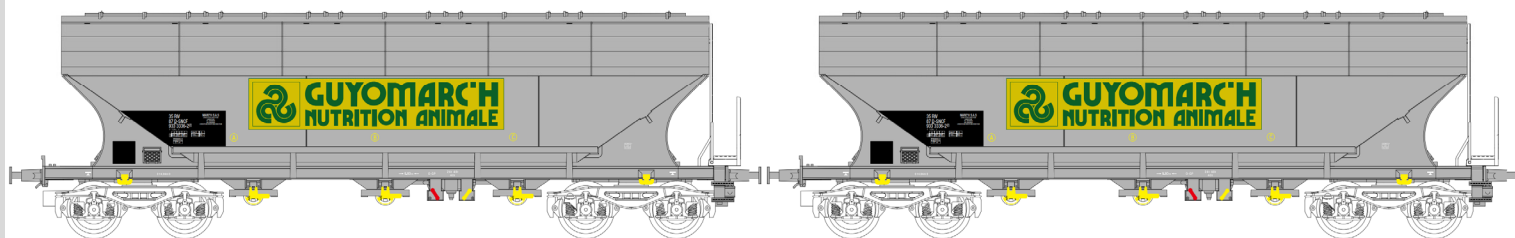

45.332 - Set A : Set mit 2 Silowagens ' MILLET ' SNCF

Ep. IV

45.333 - Set B : wie set A aber mit neuen Betriebsnummern

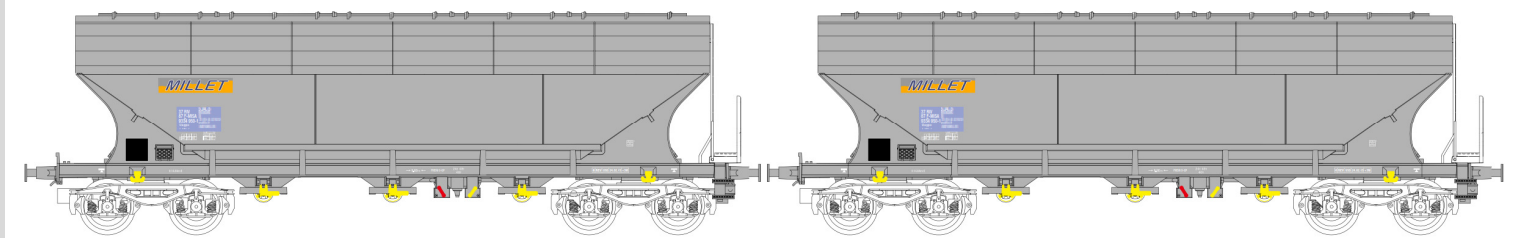

45.336 - Set A : Coffret de 2 wagons céréaliers ' Cooperl ' SNCF

Ep. IV

45.337 - Set B : comme coffret A mais avec autres numéros d'immatriculation

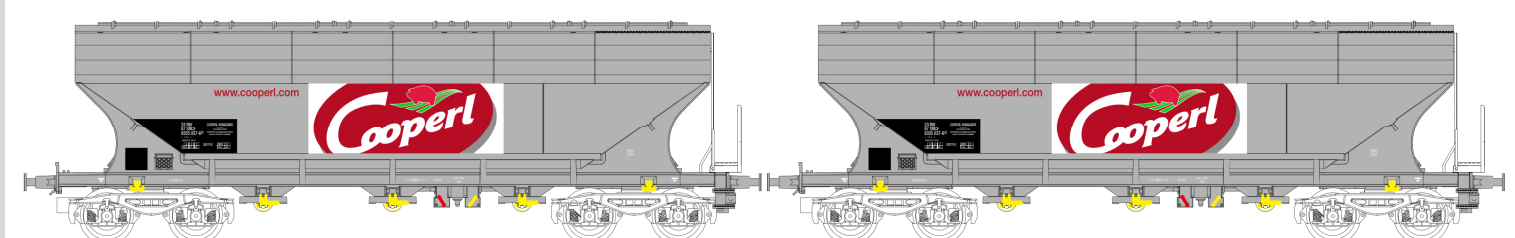



The well known grain hopper cars of B-models, with the typical welding on the car sides. Working spring buffers
Fine metal railings on the roof. Set A and B : 4 different car numbers available



Le célèbre wagon céréalier de B-Models est le seul modèle qui possède les soudures typiques sur les côtés.
Les coffrets A et B existent avec quatre numéros de wagons différentes.

45.340 - Set A : set of 2 grain hopper cars 'VTG'

D-VTGD

Ep. VI

45.341 - Set B : like set A but with different car numbers

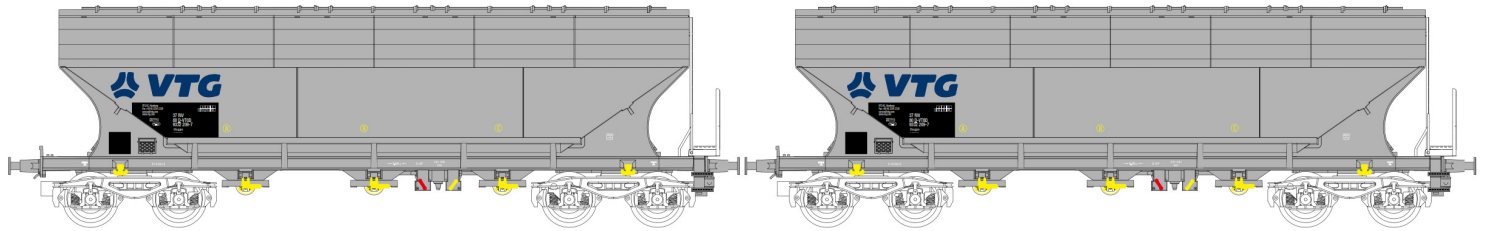

45.342 - Set A : Coffret de 2 wagons céréaliers 'MILLET - Transcéréales' F-MISA

Ep. VI

45.343 - Set B : comme coffret A mais avec autres numéros d'immatriculation

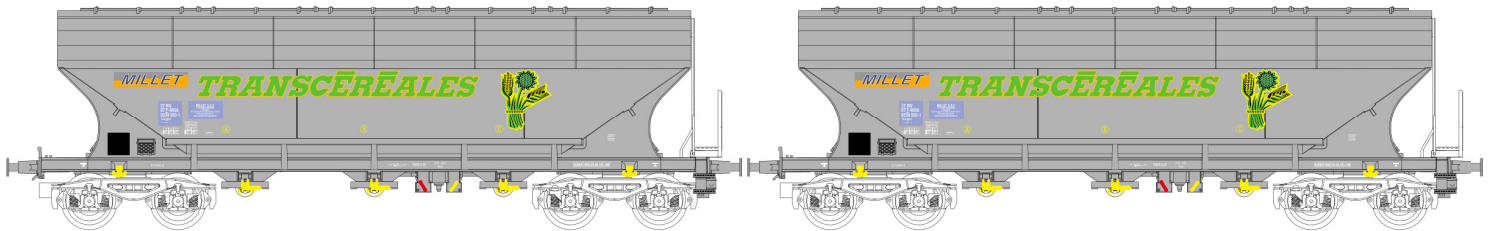

45.344 - Set A : set of 2 grain hopper cars 'Monfer' I-MOFR

Ep. IV

45.345 - Set B : like set A but with different car numbers

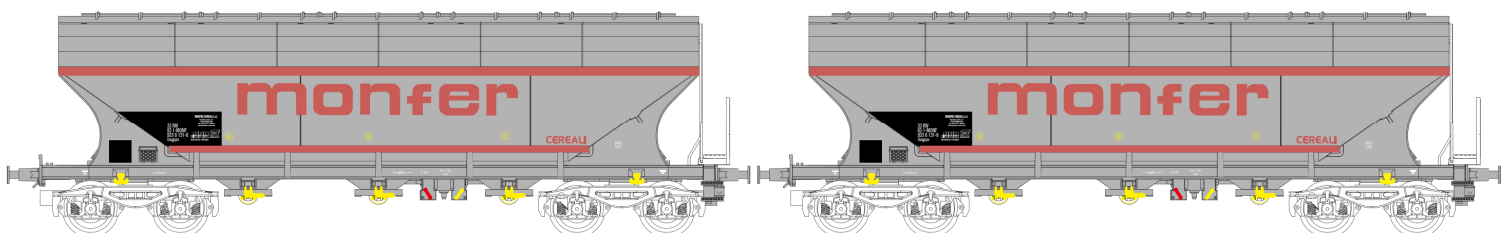

Ref. 45.418 Set A - Ref. 45.419 Set B

2 cars with loads

NMBS / SNCB



Ref. 45.420 Set A - Ref. 45.421 Set B

2 Wagon Set mit Beladung

NMBS / SNCB



Ref. 45.422 Set A - Ref. 45.423 Set B

2 wagons met belading

NMBS / SNCB



Ref. 45.462 Set A - Ref. 45.463 Set B

2 wagons sans chargements

NMBS / SNCB



Ref. 45.424 Set A - Ref. 45.425 Set B

2 Wagen Set mit Beladung

L-CFL

coming soon .. end febr.



coming soon .. end febr.



Ref. 45.428 Set A - Ref. 45.429 Set B

2 cars with loads

D-AAEC

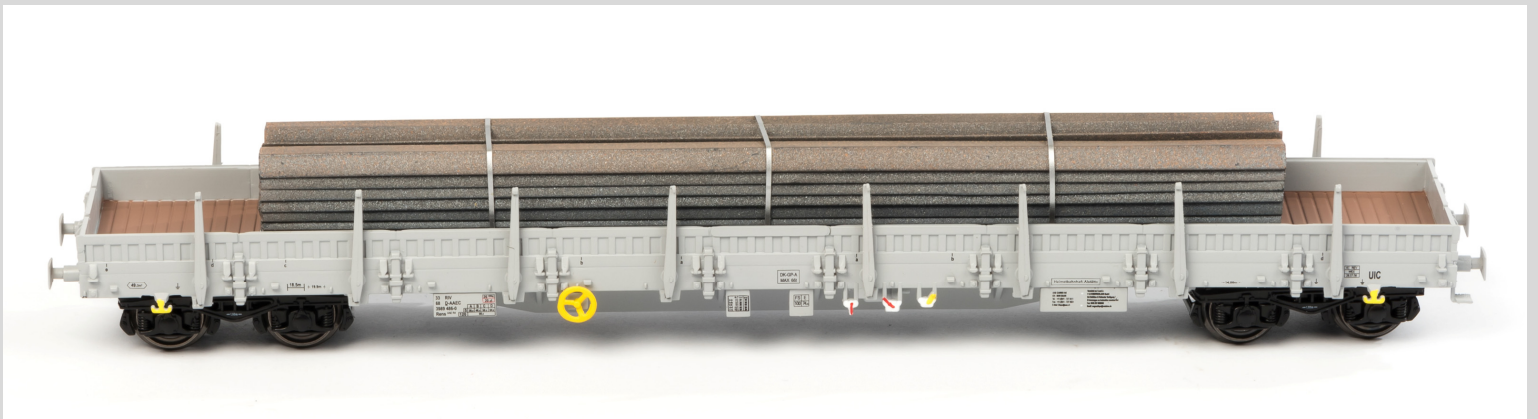
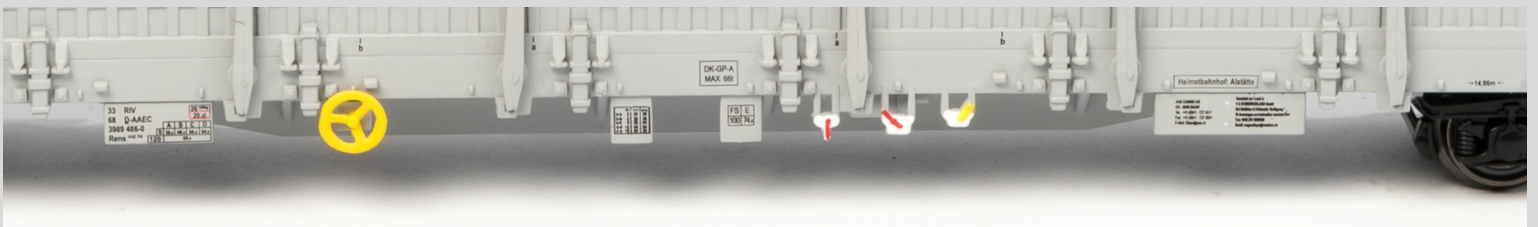

Ref. 45.430 Set A - Ref. 45.431 Set B

2 wagens met belading

D-ORME Tuc Rail



Die bekannten Rils-Wagen, im Lieferumfang zwei Rils-Wagen zu einem sehr günstigen Preis.
Die Platten sind separat auf dem Wagen montiert.

Ref. 45.634 Set A - Ref. 45.635 Set B 2 wagons **F-SNCF Ermewa-Sati**



Ref. 45.640 Set A - Ref. 45.641 Set B 2 cars **D-AAEC**





Ref. 45.646 Set A - Ref. 45.647 Set B 2 cars **S-GC**



Ref. 45.648 Set A - Ref. 45.649 Set B 2 cars **D-AAEC DB**



 De ReGs containerwagens : speciaal aangepaste platte wagens met een schuine boord van binnen voor de plaatsing van containers

 Die ReGs Containerwagen: spezial angepasste Flachwagen mit modifizierten inneren Schrägkanten zur Platzierung von Containern

 The ReGs containercars : special modified flat cars with a loading board inside for the containers.

 Les wagons conteneurs ReGs: wagon plat spécialement modifié avec un bord incliné de l'intérieur pour le placement des conteneurs





Onze Timber Cars : de rongen zullen in kleur gespoten worden en ook direct **bedrukt** zijn met de logo's. Tevens zullen alle wagens beladen zijn met echt hout , dus 3 pakken houtbelading per wagon



Unsere Rungenwagen : Die Rungen sind lackiert und mit den **Logos bedrukt**. Die Wagen werden ausserdem alle mit Echtholz beladen, d.h drei Echtholzladungen pro Wagon.

Ref. 54.200 Set A : with 3 wood loaded Sgns cars D-AAEC : Cargolink AS

54.201 Set B : same as set A but with other car numbers





9 blauwe rongen per wagen - 9 blue Timber Bunks on each car - 9 ranchers bleus par wagon - 9 ranchers bleus par wagon
Loaded with real wood !



Prototype, not final model.

The timbers on the cars are painted and printed with the logo ExTe on each timber !

 Our Timber Cars : the Timber Bunks will be painted in color and directly be **printed with the logo's** on. All cars will also be loaded with real wood, so 3 wood-load on each car

 Nos wagons pour le transport de bois: les ranchers seront peints et également équipés avec les logos. En outre tous les wagons seront chargés avec du vrai bois, donc trois chargements de bois par wagon.

Ref. 54.202 Set A : with 3 wood loaded Sgns cars D-AAEC : Hector Rail AB

54.203 Set B : same as set A but with other car numbers



9 oranje rongen per wagen - 9 orange Timber Bunks on each car - 9 Orange Rungen pro Wagen - 9 ranchers oranges par wagon
Loaded with real wood !



Prototype, not final model.

The timbers on the cars are painted and printed with the logo ExTe on each timber !

METAL EDITION

Container cars Sggmrss 90



Metal Frame

Met beweegbare klapsteunen!
Mit beweglichen Klappriegeln!
With turnable supports!
Avec supports tournant!



De containerwagen type Sggmrss is in grote aantallen gebouwd en wordt gebruikt door vele verschillende vervoerders door heel Europa. De wagen bestaat uit twee helften, die in het midden op één draaistel rusten. Elke helft heeft een maximale laadlengte van 45ft. Typische belading voor deze wagens zijn 45ft containers, omdat de laadlengte dan maximaal benut wordt. Echter worden er ook vaak 40ft containers en zelfs 30ft bulkcontainers op vervoerd.

De modellen van B-Models zijn uitgevoerd in metaal, zodat ze ook zwaar genoeg zijn om als lege wagen in een trein te rijden.



The container wagons type Sggmrss has been built in high numbers and is used by many different companies throughout Europe. The wagon consist of two halves they are connected with one bogie. Each half has a maximum loading capacity of 45ft. Typical loads for these wagons are 45ft containers, to maximize the usage of the loading capacity. However, other containers like 40ft and even 30ft bulkcontainers are also frequently seen on these wagons.

The scale models of these wagons that B-Models makes have metal frames, so they are heavy enough to be used unloaded.



Die Containertragwagen des Typs Sggmrss sind in grossen Stückzahlen gebaut worden und werden eingesetzt von vielen verschiedenen Transportunternehmen durch ganz Europa eingesetzt. Die Wagen sind bestehent aus zwei Hälften die in der Mitte auf einem Drehgestell aufliegen. Jede Wagenhälfte hat eine Ladelänge von 45ft. Typische Beladungen sind 45ft, wodurch die Ladelänge maximal genutzt wird. Andere Container wie 40ft und 30ft Bulkcontainer werden aber auch regelmässig verladen.





Die B-Models Modelle haben metallene Rahmen, dadurch haben die Wagen ein ausreichendes Eigengewicht um ein problemloses fahren auf der Anlage zu gewährleisten.







Le wagon porte-containers du type Sggmrss est construit en grandes quantités et est utilisé par des différents transporteurs dans toute l'Europe. Le wagon est composé de deux moitiés qui reposent au milieu sur un bogie. Chaque moitié dispose d'une longueur maximum de 45ft. Les containers de 45ft sont des chargements typiques du fait que la longueur du chargement est exploitée au maximum. Les containers de 40ft et 30ft sont également transportés.

Les cadres des modèles de chez B-Models sont fabriqués en métal et donc assez lourds afin de permettre une bonne circulation sur votre réseau à vide.

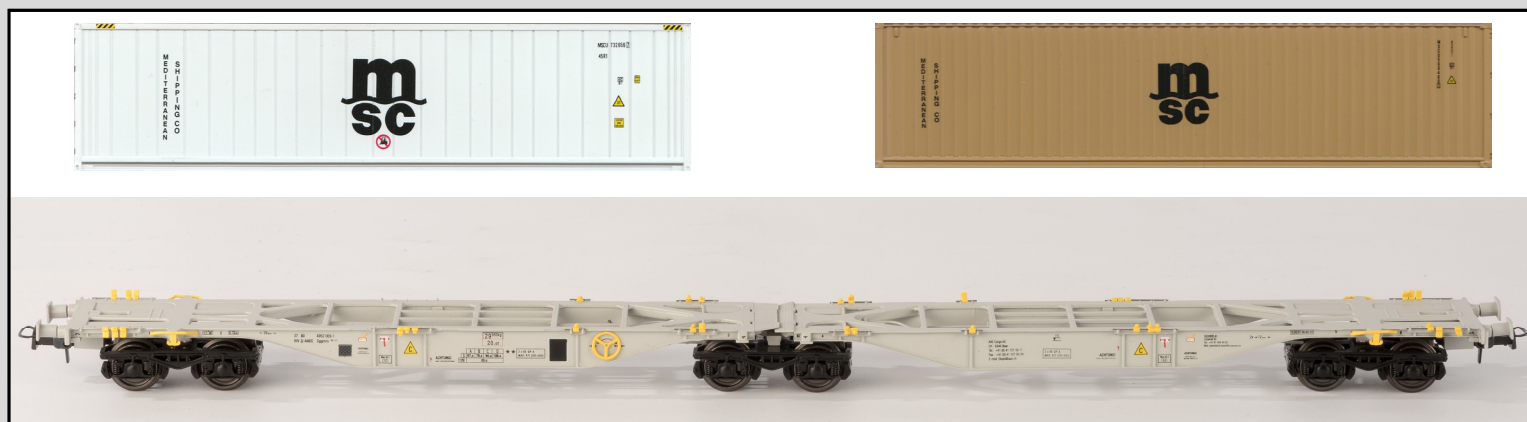





-  55.100 - Crossrail, blauw, opschrift D-XRAIL, beladen met 2x 45ft container P&O Ferrymasters
-  55.100 - Crossrail, blau, D-XRAIL, beladen mit 2x 45ft Container P&O Ferrymasters
-  55.100 - Crossrail, blue, D-XRAIL, loaded with 2x 45ft container P&O Ferrymasters
-  55.100 - Crossrail, bleu, D-XRAIL, chargé avec 2x 45ft conteneur P&O Ferrymasters







-  55.101 - AAE Cargo, verhuurd aan Crossrail, lichtgrijs, opschrift D-AAEC, beladen met 1x 40ft container MSC & 1x 40ft koel container MSC
-  55.101 - AAE Cargo, vermietet an Crossrail, hellgrau, Anschriften D-AAEC, beladen mit 1x 40ft Container MSC & 1x 40ft Kühlcontainer MSC
-  55.101 - AAE Cargo, rented out to Crossrail, light grey, inscription D-AAEC, loaded with 1x 40ft container MSC & 1x 40ft reefer container MSC
-  55.101 - AAE Cargo, loué à Crossrail, gris clair, inscription D-AAEC, chargé avec 1x 40ft conteneur MSC & 1x 40ft koel conteneur MSC







-  55.102 - Hupac, lichtgrijs met Hupac logo, opschrift CH-HUPAC, beladen met 2x 45f container Ge-eX
-  55.102 - Hupac, hellgrau mit Hupac Logo, Anschriften CH-HUPAC, beladen mit 2x 45f Container Ge-eX
-  55.102 - Hupac, light grey with Hupac logo, inscription CH-HUPAC, loaded with 2x 45f container Ge-eX
-  55.102 - Hupac, gris clair avec Hupac logo, inscription CH-HUPAC, chargé avec 2x 45f container Ge-eX







-  55.103 - AAE Cargo, grijs, D-AAEC, geen huurdersopschriften, beladen met 1x 40ft koel container Maersk & 1x 40ft koel container Maersk Sealand
-  55.103 - AAE Cargo, grau, D-AAEC, keine Mieteranschriften, beladen mit 1x 40ft Kühlcontainer Maersk & 1x 40ft Kühlcontainer Maersk Sealand
-  55.103 - AAE Cargo, grey, D-AAEC, no rental inscriptions, loaded with 1x 40ft reefer container Maersk & 1x 40ft reefer container Maersk Sealand
-  55.103 - AAE Cargo, gris, D-AAEC, sans inscriptions locataire, chargé avec 1x 40ft frigo conteneur Maersk & 1x 40ft frigo conteneur Maersk Sealand

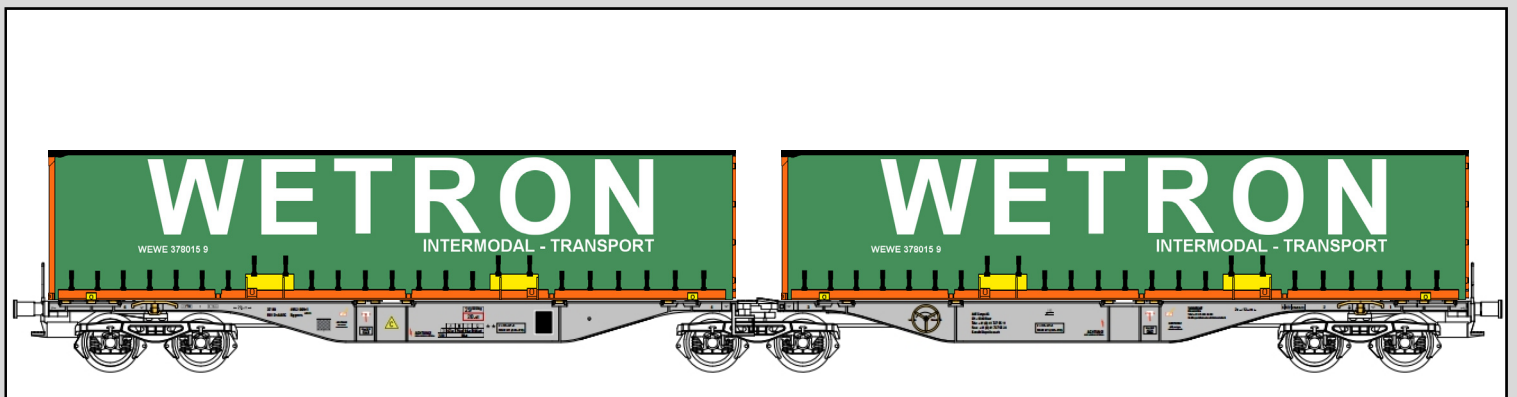

-  55.104 - AAE Cargo, verhuurd aan TRW, lichtgrijs met TRW logo, opschrift D-AAEC, beladen met 2x 45ft zeilwand container Ewals Cargo Care
-  55.104 - AAE Cargo, vermietet an TRW, hellgrau mit TRW Logo, Anschriften D-AAEC, beladen mit 2x 45ft Container mit Plane Ewals Cargo Care
-  55.104 - AAE Cargo, rented out to TRW, light grey with TRW logo, inscription D-AAEC, loaded with 2x 45ft tarp-side container Ewals Cargo Care
-  55.104 - AAE Cargo, loué à TRW, gris clair, avec logo TRW, inscription D-AAEC, chargé avec 2x 45ft bache conteneur Ewals Cargo Care



-  55.105 - AAE Cargo, lichtgrijs, verhuurd aan TX Logistiek, opschrift D-AAEC, beladen met 2x 45ft zeilwand container Wetron
-  55.105 - AAE Cargo, hellgrau, vermietet an TX Logistiek, Anschriften D-AAEC, beladen mit 2x 45ft Container mit Plane Wetron
-  55.105 - AAE Cargo, light grey, rented out to TX Logistiek, inscription D-AAEC, loaded with 2x 45ft tarp-side container Wetron
-  55.105 - AAE Cargo, gris clair, loué à TX Logistiek, inscription D-AAEC, chargé avec 2x 45ft bache container Wetron

Collectors Edition 1

IFB shuttle Zeebrugge - Italy



IFB laat dagelijks diverse containershuttles rijden tussen Zeebrugge (BE) en diverse bestemmingen in Italië. Deze bestaan uit wagens type Sgns en Sggmrss, en zijn grotendeels beladen met 45ft containers. Met deze Collector's Edition van B-Models krijgt u de mogelijkheid om deze trein realistisch samen te stellen. De serie zal de komende jaren steeds voortgezet worden, zodat er genoeg wagens beschikbaar voor een trein op realistische lengte.



IFB runs several daily container shuttles between Zeebrugge (BE) and various Italian destinations. These trains consists of container wagons type Sgns and Sggmrss, and are mostly loaded with 45ft containers. With this Collector's Edition you get the possibility to build this train very realistically. The serie will be continued over the coming years, so there will be enough wagons available to build a complete train.



IFB setzt täglich mehrere Containerzüge zwischen Zeebrugge (BE) und Italien ein. Diese Züge werden zusammengestellt aus Wagen des Typs Sgns und Sggmrss und werden hauptsächlich mit 45ft Containern beladen. Mit dieser Collector's Edition haben Sie die Möglichkeit diesen Zug realistisch nachzubilden. Die Serie wird in den kommenden Jahren erweitert, so dass genügend Wagen verfügbar sind um einen realistisch langen Zug zu bilden.



L'IFB fait circuler chaque jour des convois de containers entre Zeebrugge (B) et l' Italie. Ceux-ci sont composés de wagons du type Sgns et Sggmrss et sont chargés, en particulier, avec des containers de 45ft. La Collector's Edition de B-Models vous donne la possibilité de réaliser des longs convois. La série des wagons conteneurs sera complétée au fil des années afin de pouvoir disposer assez de wagons.



- 59.100 - AAE Cargo, verhuurd aan IFB, lichtgrijs met IFB logo, opschrift D-AAEC, beladen met 2x 45ft container ECS
- 59.100 - AAE Cargo, verhuurd aan IFB, hellgrau mit IFB Logo, D-AAEC Beschriftung, beladen mit 2x 45ft Container ECS
- 59.100 - AAE Cargo, rented out to IFB, light grey with IFB logo, inscription D-AAEC, loaded with 2x 45ft container ECS
- 59.100 - AAE Cargo, loué à IFB, gris clair avec logo IFB, inscription D-AAEC, chargé avec 2x 45ft conteneur ECS



- 59.101 - Touax, bruin, met geel Touax logo, opschrift B-TOUAX, beladen met 2x 45ft container DHL
- 59.101 - Touax, braun, mit gelbem Touax Logo, B-TOUAX Beschriftung, beladen mit 2x 45ft Container DHL
- 59.101 - Touax, brown, with yellow Touax logo, inscription B-TOUAX, loaded with 2x 45ft container DHL
- 59.101 - Touax, brun, avec logo Touax jaune, inscription B-TOUAX, chargé avec 2x 45ft container DHL

Collectors Edition 2

ERS shuttle Rotterdam - Melzo



ERS Railways laat dagelijks containershuttles rijden tussen Rotterdam (NL) en Melzo (I). Deze bestaan uit wagens type Sgns en Sggmrss. De treinen zijn grotendeels beladen met 45ft containers. Met deze Collector's Edition van B-Models krijgt u de mogelijkheid om deze trein realistisch samen te stellen. De serie zal de komende jaren steeds voortgezet worden, zodat er genoeg wagens beschikbaar voor een trein op realistische lengte.



ERS Railways runs a daily container shuttles between Rotterdam (NL) and Melzo (I). This train consists of container wagons type Sgns and Sggmrss. These trains are mostly loaded with 45ft containers. With this Collector's Edition you get the possibility to build this train very realistically. The serie will be continued over the coming years, so there will be enough wagons available to build a complete train.



Die ERS Railways setzt täglich mehrere Containerzüge zwischen Rotterdam (NL) und Melzo (I) ein. Diese Züge werden zusammengestellt aus Wagen des Typs Sgns und Sggmrss und werden hauptsächlich mit 45ft Containern beladen. Mit dieser Collector's Edition haben Sie die Möglichkeit diesen Zug realistisch nachzubilden. Die Serie wird in den kommenden Jahren erweitert, so dass genügend Wagen verfügbar sind um einen realistisch langen Zug zu bilden.



L'ERS Railways fait circuler chaque jour des convois de containers entre Rotterdam (NL) et Melzo (I). Ceux-ci sont composés de wagons du type Sgns et Sggmrss et sont chargés, en particulier, avec des containers de 45ft. La Collector's Edition de B-Models vous donne la possibilité de réaliser des longs convois. La série des wagons conteneurs sera complétée au fil des années afin de pouvoir disposer assez de wagons..



59.200 - AAE Cargo, verhuurd aan ERS, lichtgrijs, opschrift D-AAEC, beladen met 2x 45ft container Samskip



59.200 - AAE Cargo, vermietet an ERS, hellgrau, D-AAEC Beschriftung , beladen mit 2x 45ft Container Samskip



59.200 - AAE Cargo, rented out to ERS, light grey, inscription D-AAEC, loaded with 2x 45ft container Samskip



59.200 - AAE Cargo, loué à ERS, gris clair, inscription D-AAEC, chargé avec 2x 45ft conteneur Samskip



59.201 - AAE Cargo, verhuurd aan ERS, lichtgrijs, opschrift D-AAEC, beladen met 1x 45ft container Eucon & 1x 45ft container Containerships



59.201 - AAE Cargo, vermietet an ERS, hellgrau, D-AAEC Beschriftung , beladen mit 1x 45ft Container Eucon & 1x 45ft Container Containerships



59.201 - AAE Cargo, rented out to ERS, light grey, inscription D-AAEC, loaded with 1x 45ft container Eucon & 1x 45ft container Containerships



59.201 - AAE Cargo, loué à ERS, gris clair, inscription D-AAEC, chargé avec 1x 45ft conteneur Eucon & 1x 45ft conteneur Containerships

Collectors Edition 3

Ambrogio shuttle Gallarate - Muizen / Neuss



Ambrogio Intermodal laat dagelijks containershuttles rijden tussen Gallarate (I) en Muizen (BE) en tussen Gallarate (I) en Neuss (DE). Deze bestaan uitsluitend uit wagens type Sggmrss. De treinen zijn beladen met 45ft containers en zeilwand containers. Met deze Collector's Edition van B-Models krijgt u de mogelijkheid om deze trein realistisch samen te stellen. De serie zal de komende jaren steeds voortgezet worden, zodat er genoeg wagens beschikbaar zijn voor een trein op realistische lengte.



Ambrogio Intermodal runs a daily container shuttles between Gallarate (I) and Muizen (BE) and between Gallarate (I) and Neuss (DE). This train consists of container wagons type Sggmrss. These trains are loaded with 45ft containers and tarp-sided containers. With this Collector's Edition you get the possibility to build this train very realistically. The serie will be continued over the coming years, so there will be enough wagons available to build a complete train.



Ambrogio Intermodal setzt täglich mehrere Containerzüge zwischen Gallarate (I) und Muizen (BE) und zwischen Gallarate (I) und Neuss (DE) ein. Diese Züge werden zusammengestellt aus Wagen des Typs Sggmrss und werden hauptsächlich mit 45ft Containern beladen. Mit dieser Collector's Edition haben Sie die Möglichkeit diesen Zug realistisch nachzubilden. Die Serie wird in den kommenden Jahren erweitert, so dass genügend Wagen verfügbar sind um einen realistisch langen Zug zu bilden.



Ambrogio Intermodal fait circuler chaque jour des convois de containers entre entre Gallarate (I) et Muizen (BE) et entre Gallarate (I) et Neuss (DE). Ceux-ci sont composés de wagons du type Sggmrss et sont chargés, en particulier, avec des containers de 45ft. La Collector's Edition de B-Models vous donne la possibilité de réaliser des longs convois. La série des wagons conteneurs sera complétée au fil des années afin de pouvoir disposer assez de wagons.







- 59.300 - Ambrogio, grijs met Ambrogio logo, opschrift I-AMBR, met 2x 45ft zeilwand container Ambrogio
- 59.300 - Ambrogio, grau mit Ambrogio Logo, I-AMBR Beschriftung, mit 2x 45ft Cont. mit Plane Ambrogio
- 59.300 - Ambrogio, grey with Ambrogio logo, inscription I-AMBR, with 2x 45ft tarp-side container Ambrogio
- 59.300 - Ambrogio, gris avec Ambrogio logo, inscription I-AMBR, avec 2x 45ft bache conteneur Ambrogio

- 59.301 - andere nummers
- 59.301 - unters. Betriebsn.
- 59.301 - other numbers
- 59.301 - d'autres numéros



- 59.302 - Ambrogio, grijs met Ambrogio logo, opschrift I-AMBR, beladen met 2x 45ft container Ambrogio
- 59.302 - Ambrogio, grau mit Ambrogio Logo, I-AMBR Beschriftung, beladen mit 2x 45ft Container Ambrogio
- 59.302 - Ambrogio, grey with Ambrogio logo, inscription I-AMBR, loaded with 2x 45ft container Ambrogio
- 59.302 - Ambrogio, gris avec Ambrogio logo, inscription I-AMBR, chargé avec 2x 45ft conteneur Ambrogio

Artikel 92.101

-  Set met 3 wagens SBB-Cargo, originele versie, 1° Serie : 1 gele haak
-  Set mit 3 SBB-Cargo Wagen, Ablieferungszustand, Serie 1 : 1 Seilanker
-  Box with 3 cars SBB-Cargo, Original version, Serie 1 : one yellow clamp
-  Coffret avec 3 wagons SBB-Cargo, version original, 1° Serie : 1 crochet jaune







Met dank aan Peter Hürzeler

Special edition : distribution in Europe by B-models, but in Switzerland exclusive sold by EYRO Modellbahn , www.eyro.ch



Prototype

Artikel 92.102

-  Set met 3 wagens SBB-Cargo, originele versie, 2° Serie : 2 gele haken
-  Set mit 3 SBB-Cargo Wagen, Ablieferungszustand, Serie 2 : 2 Seilanker
-  Box with 3 cars SBB-Cargo, Original version, Serie 2 : two yellow clamps
-  Coffret avec 3 wagons SBB-Cargo, version original, 2° Serie : 2 crochets jaune



Met dank aan Peter Hürzeler

Spezial Edition : Vertrieb in Europa durch B-Models, aber in der Schweiz exklusiv vertrieben durch EYRO Modellbahn , www.eyro.ch



Prototype



Prototype

Tads wagon NMBS - SNCB **X-pedys**

Ref. VB-83004 : Set met 3 wagons, groen , **X-pedys** (zoals 83002) : 159,90 euro
Coffret avec 3 wagons, vert , **X-pedys** (comme 83002) : 159,90 euro



Tads wagon NMBS - SNCB **B-cargo**

Ref. VB-83006 : Set met 3 wagons, groen , **B-Cargo** : 159,90 euro
Coffret avec 3 wagons, vert , **B-Cargo** : 159,90 euro



Tads wagon B - ERSA Ermewa

Ref. VB-83007 : Set met 3 wagons, grijs , B-Ersa Ermewa : 159,90 euro
 Coffret avec 3 wagons, gris , B-Ersa Ermewa : 159,90 euro



project : Tads PL - PULAWY



project : PL - PULAWY



Tremie Balastwagon NMBS - SNCB

Ref. VB-84008 : INFRABEL

Set NMBS, 3 balastwagens + belading,
Infrabel, tijdperk VI

Rerun - new numbers

Coffret SNCB, 3 wagons Tremie + chargement,
Infrabel, Epoque VI

NEW 17



Tremie Balastwagon SNCF

Ref. VB-84204 :

Set SNCF, 3 balastwagens + belading,
Direction de l'infrastructure

NEW 17



Neu in unserem Programm für das Jahr 2017 :

New in our program for 2017 :

Digital Installation Decoder

NEW 17

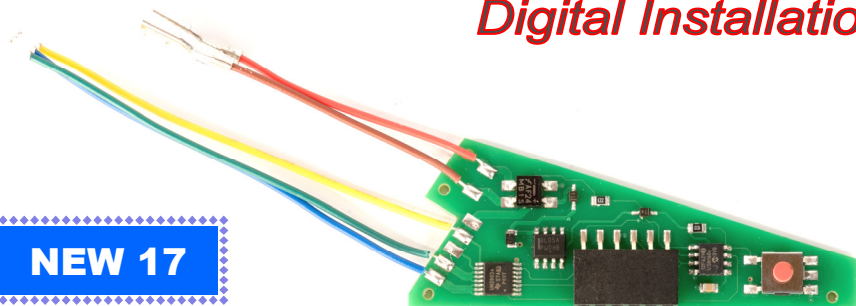

Ref 88.701 : Digital C-rail decoder,
compatibel für Märklin* system

UVP : 19,90 euro



De Belgische seinen - Les signaux belges



Alles in stock - Tous en stock

Nummer	Omschrijving	Prijs
66.310	Ronde seinplaat, 3 lampen : Rood-Geel-Geel <i>Plaque de signalisation ronde à 3 feux : rouge-jaune-jaune.</i>	€ 24,90
66.315	Ronde seinplaat, 3 lampen + V keeper <i>Plaque de signalisation ronde à 3 feux et chevron.</i>	€ 26,90
66.400	Ronde seinplaat, 4 lampen <i>Plaque de signalisation ronde à 4 feux.</i>	€ 26,90
66.405	Ronde seinplaat, 4 lampen + V keeper <i>Plaque de signalisation ronde à 4 feux et chevron.</i>	€ 31,90
66.500	Ronde seinplaat, 5 lampen <i>Plaque de signalisation ronde à 5 feux.</i>	€ 26,90
66.505	Ronde seinplaat, 5 lampen + V keeper <i>Plaque de signalisation ronde à 5 feux et chevron.</i>	€ 31,90
76.400	Rechthoekige seinplaat, 4 lampen <i>Plaque de signalisation rectangulaire à 4 feux.</i>	€ 26,90
76.405	Rechthoekige seinplaat, 4 lampen + V keeper <i>Plaque de signalisation rectangulaire à 4 feux et chevron.</i>	€ 31,90
76.500	Rechthoekige seinplaat, 5 lampen <i>Plaque de signalisation rectangulaire à 5 feux.</i>	€ 26,90
76.505	Rechthoekige seinplaat, 5 lampen + V keeper <i>Plaque de signalisation rectangulaire à 5 feux et chevron.</i>	€ 31,90

Multi Led-Strip Beleuchtung



Ref 66.111 : Waggon-Innenbeleuchtung

12 mini LED : Warm Weiss + Weiss in eine Led-strip !
Flackerschutz und Konstantstromquelle integriert.



De Belgische seinen - Les signaux belges

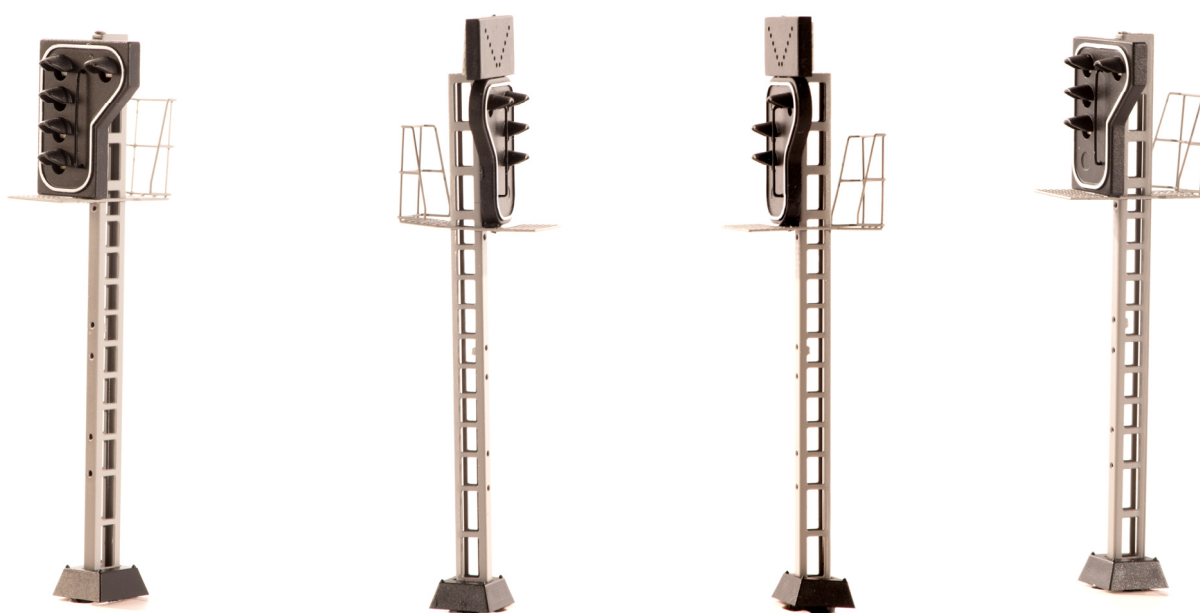

66.000	Z Rangeersein op voet, zelfbouwpakket <i>Signal de manoeuvre à pied (Kit).</i>	€ 12,50
66.000	Rangeersein op voet, gemonteerd <i>Signal de manoeuvre à pied (monté).</i>	€ 16,90
80.121	accessoires : 6 'seinladdertjes' <i>Accessoires : 6 échelles de signal.</i>	€ 4,90
80.122	accessoires : Telefoonkastje met T, overschrijdingskroontje seinnummer bord, blauwe cirkel met pijl <i>Accessoires : Boîte téléphonique avec marquage T, plaque d'immatriculation du signal, cercle bleu avec flèche.</i>	€ 4,90
88.601	Digitale seindecoder met 10 uitgangen <i>Décodeur de Signal digital avec 10 sorties.</i>	€ 49,90

Van Biervliet .com

HO - 1:87

Euro-Tank-Car .eu

HO - 1:87

Scale 1 - 1:32

Modern Knick-tankcar with detailed printings and spring buffers. Tankcar with real 'knick' , also on platform
Moderne Knick-Kesselwagens mit detaillierte Bedruckung und Federpuffer, mit 'knick' am platform !

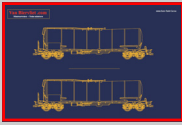

Set of 2 cars : 64,90 euro !
Set mit 2 wagons : 64,90 euro !



VB-81036 : Set 2 wagons ' MOL '

H-MAV



VB-81038 : Set 2 wagons ' Solvay Natronchemie '

NMBS / SNCB



VB-81039 : Set 2 wagons ' GATX '

New car number !



VB-81040 : Set 2 wagons ' Millet '

F-MISA



VB-81041 : Set 2 wagons ' Millet ChemOil '

F-MISA



VB-81042 : Set 2 wagons ' Gatx DHL '

D-GATX



VB-81043 : Set 2 wagons ' GATX ' (kleines logo)

D-GATXD



VB-81044 : Set 2 wagons ' Atir-Rail '

NL-ATTR



VB-81045 : Set 2 wagons ' GATX - ChemOil '

D-GATXD



VB-81046 : Set 2 wagons ' CD Cargo '

CZ-CDCR



VB-81047 : Set 2 wagons ' RYKO '

CZ-RYKO



Spur 1 - 1:32 - Scale 1

Moderne Knick-Kesselwagen mit detaillierte Bedruckung und Federpuffer, mit 'knick' am platform !



Each car has 2 types of couplers in box !



Spur 1 - 1:32 - Scale 1

limitiertes serie Nr 50 stück pro nummer



Spur 1 - 1:32 - Scale 1



Spur 1 - 1:32 - Scale 1



Spur 1 - 1:32 - Scale 1

Moderne Knick-Kesselwagens mit detaillierte Bedruckung und Federpuffer, mit 'knick' am platform !



limitiertes serie Nr 50 stück pro nummer



Prototype

Artikel : SP-1012 : Knick-Kesselwagen ' GATX '

New car number !



Spur 1 - 1:32 - Scale 1

Artikel : SP-1022 :

Knick-Kesselwagen ' Wascosa '

New car number !



Price : 269 euro

PREIS : 269 euro

Prijs : 269 euro

Artikel : SP-1031 :

Knick-Kesselwagen ' KVG '

Tirage de 50 pcs



Price : 269 euro

PREIS : 269 euro

Prijs : 269 euro

Artikel : SP-1042 :

Knick-Kesselwagen ' GATX '

New car number !



Price : 269 euro

PREIS : 269 euro

Prijs : 269 euro

Artikel : SP-1051 :

Knick-Kesselwagen ' Millet '

only 50 pcs of each !



Price : 269 euro

PREIS : 269 euro

Prijs : 269 euro

Ref n° : 90.208 Set InnoWaggon wagens, RockTainer ORE - I'm from Austria



Ref n° : 90.209 Set InnoWaggon wagens, RockTainer ORE - Green Steiermark



Ref n° : 90.211 Set InnoWaggon wagens, RockTainer ORE - yellow



Rerun - new numbers

Ref n° : 90.212 Set InnoWaggon wagens, RockTainer ORE - Grey



Rerun - new numbers

Ref n° : 90.213 Set InnoWaggon wagens, RockTainer ORE - Red



Rerun - new numbers

Ref n° : 90.214 Set InnoWaggon wagens, RockTainer ORE - blue



Rerun - new numbers

Ref n° : 90.106 Set InnoWaggon wagens, beladen mit 6 containers Innofreight



Rerun - new numbers

Ref n° : 90.107 Set InnoWaggon wagens, beladen mit 6 containers Innofreight + VTG



Ref n° : 90.108 Set InnoWaggon wagens, beladen mit 6 containers Knauf + VTG



Ref n° : 90.300 Set InnoWaggon wagens, the INFRA RockTainer



InnoFreight Infra Rocktainer mit Beladung



Ref n° : 90.301 Set InnoWaggon wagens, the INFRA RockTainer

Wie 90.300, mit verschiedene Wagennummern

Like set 90.300 but with other car numbers.

Ref n° : 90.400 Set InnoWaggon wagens, CZ Cargo for Steel Transport

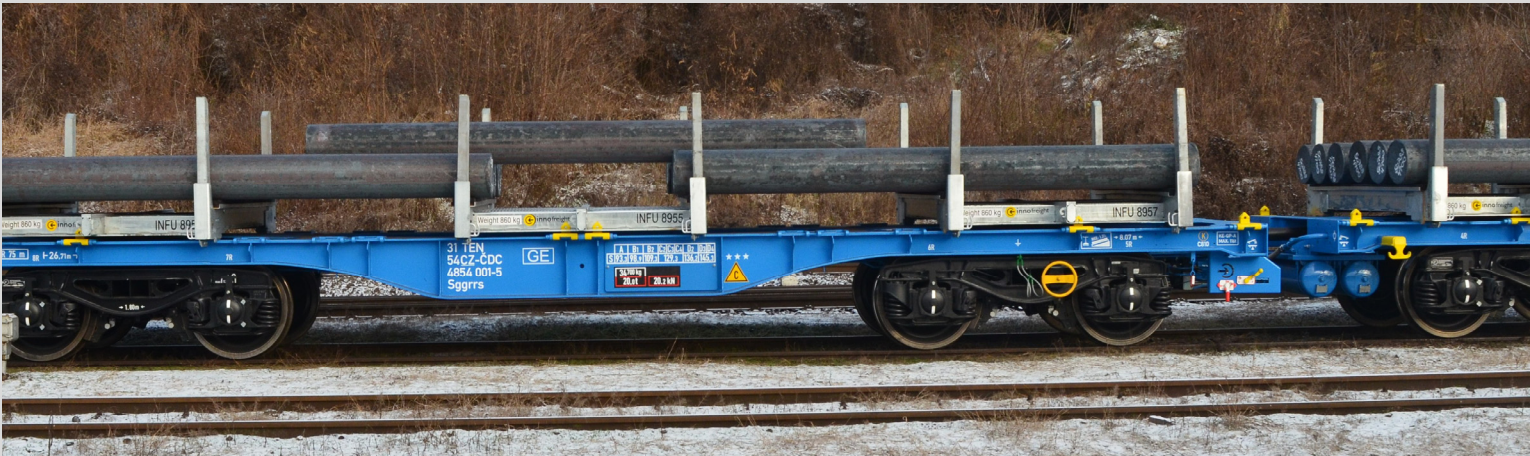

Ref n° : 90.450 Set InnoWaggon wagens, Hectorrail transport of Roundwood for SCA



Check also our website : www.B-models.be for a lot of pictures from the rail innofreight cars

Sgns wagon A-ÖBB , beladen mit containers ‘ Koks - Kohle ‘

Ref n° 90.800.1 : Wagon 1
90.800.2 : Wagon 2, like wagon 1 but with other car and container numbers



Sgns wagon A-RCW , beladen mit containers ‘ Innofreight - Captrain ‘

Ref n° 90.801.1 : Wagon 1
90.801.2 : Wagon 2, like wagon 1 but with other car and container numbers



Containers in project

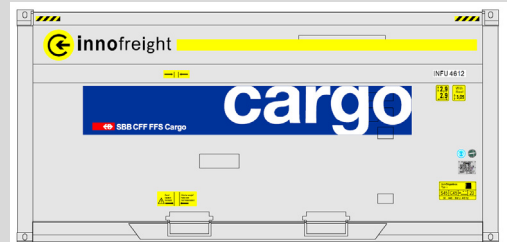
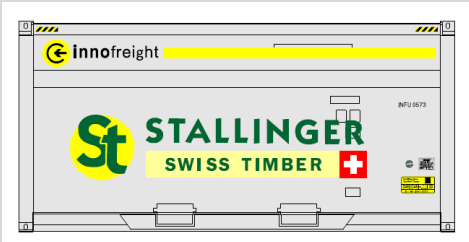

Ref n° : 90.802 Sgns wagon D-AAEC , beladen mit containers ‘ Fortum ‘

Ref n° 90.802.1 : Wagon 1
 90.802.2 : Wagon 2, like wagon 1 but with other car and container numbers
 90.802.3 : Wagon 3, like wagon 1 but with other car and container numbers



InnoFreight delivered 180pcs new XXXL containers to Fortum...these are really big ones : 175m3 loading capacity !! on a 60ft-wagon.



Containers in project

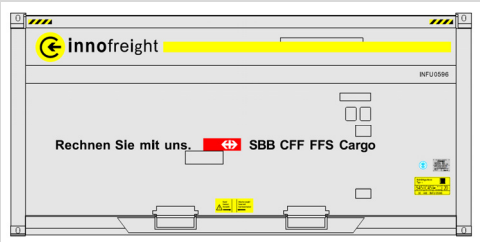

www.B-models.be

E-mail : contact@b-models.be

www.Euro-Tank-Car.eu

www.Budget-Line.com

www.VanBiervliet.com



© Van Biervliet. Brochure is zuiver informatief. Artikelen zolang de voorraad strekt en onder voorbehoud van wijzigingen en/of drukfouten.
Met dank aan de treinspotters en liefhebbers voor het mogen gebruiken van de mooie foto's.
Speciale dank aan : MC, KVDW, PA, SD, PG, S en CC

Verwijzingen naar andere merken of logo's zijn zuiver informatief. Dit enkel om de klant zo goed als mogelijk te informeren.
Deze brochure vervangt alle voorgaande. Brochure januari 2017. Design : Kristof