

# ⓑ - models

## 2019



*Budget - Line*

**Euro-Tank-Car .eu**

**Van Biervliet .com**

€ 2

**B** - models

# AM 54 NMBS / SNCB



AM 54 : model number 088

Ep. IV-V



Version			Versie		
<b>7003.01</b>	<i>2-Rails = CC</i>	Courant continu	<b>7003.01</b>	<i>Gelijkstroom DC</i>	conventioneel
<b>7003.02</b>	"	Courant continu digital	<b>7003.02</b>	"	Digitaal
<b>7003.03</b>	"	CC digital SOUND	<b>7003.03</b>	"	Digitaal Sound

Version			Versie		
<b>7003.04</b>	<i>pour Märklin*</i>	Digital Mfx	<b>7003.04</b>	<i>voor Märklin*</i>	Digitaal Mfx
<b>7003.05</b>	"	Digital SOUND Mfx	<b>7003.05</b>	"	Dig.SOUND Mfx

**OPTIE 1 :** dubbele, wisselende cabineverlichting + interieurverlichting

**OPTION 1 :** double éclairage cabine + éclairage d'intérieur

**OPTION 1 :** changing cabine lights + interior lights

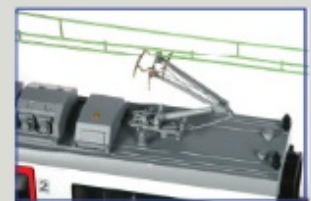
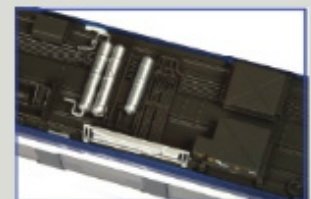
**VB-6002 :** 3-Delig electrisch Treinstel « Desiro 08203 / direction Liège - Guillemins »*gelimiteerde oplage - Limited edition - édition limitée***Versies 3-delige DESIRO / Versions 3 éléments DESIRO**

Version		Versie
VB-6002.2	<i>pour Märklin*</i> Digital Mfx	VB-6002.2 <i>voor Märklin*</i> Digitaal Mfx
VB-6002.4	“ Dig. SOUND Mfx	VB-6002.4 “ Dig.SOUND Mfx

VB-6002.5	<i>2-Rails = CC</i> Courant continu	VB-6002.5 <i>Gelijkstroom</i> conventioneel
VB-6002.6	“ Courant continu digital	VB-6002.6 “ Digitaal
VB-6002.7	“ CC digital SOUND	VB-6002.7 “ Digitaal Sound

**OPTIE 1 :** dubbele, wisselende cabineverlichting + interieurverlichting in de 3 rijtuigen  
+ schakelbaar 'bestemmingsbord' op front.

**OPTION 1 :** double éclairage cabine + éclairage intérieur dans les 3 voitures  
+ l'affichage de destination interchangeable à l'avant



## Ⓑ - models



De elektrische treinstellen AM 56 'BUDD', hun uiterlijk was echter anders vanwege de roestvrij stalen zijkanten gemaakt van golfplaten, die niet moesten worden geverfd, gebouwd volgens de methode ontwikkeld door de Amerikaanse Budd, vandaar de bijnaam die aan dit rollend materieel wordt gegeven. Dit werd ook op grote schaal bij de SNCF toegepast in deze periode.

De AM 56 circuleerde op de verbinding Brussel - Namen - Luxemburg. Later over gans België

*Les automotrices AM 56 'BUDD', leur apparence était différente en raison des côtés en acier inoxydable fabriqués en tôle ondulée, qui ne nécessitaient pas de peinture, construits selon la méthode mise au point par American Budd, d'où le surnom donné à ce matériel roulant.*

*L'AM56 a principalement circulé sur la ligne Bruxelles - Namur - Luxembourg*

# TOP - Neuheit 2019

## AM 56 BUDD



Foto met dank aan ACEC

We brengen in model het nummer 130 met volledig zilveren dak.  
Dit is de eerste versie met enkele koplampen en 2 panto's.  
In sept. 1956 werd dit treinstel zelfs gebruikt voor de inhuldiging van de elektrificatie van de lijn naar Luxemburg.

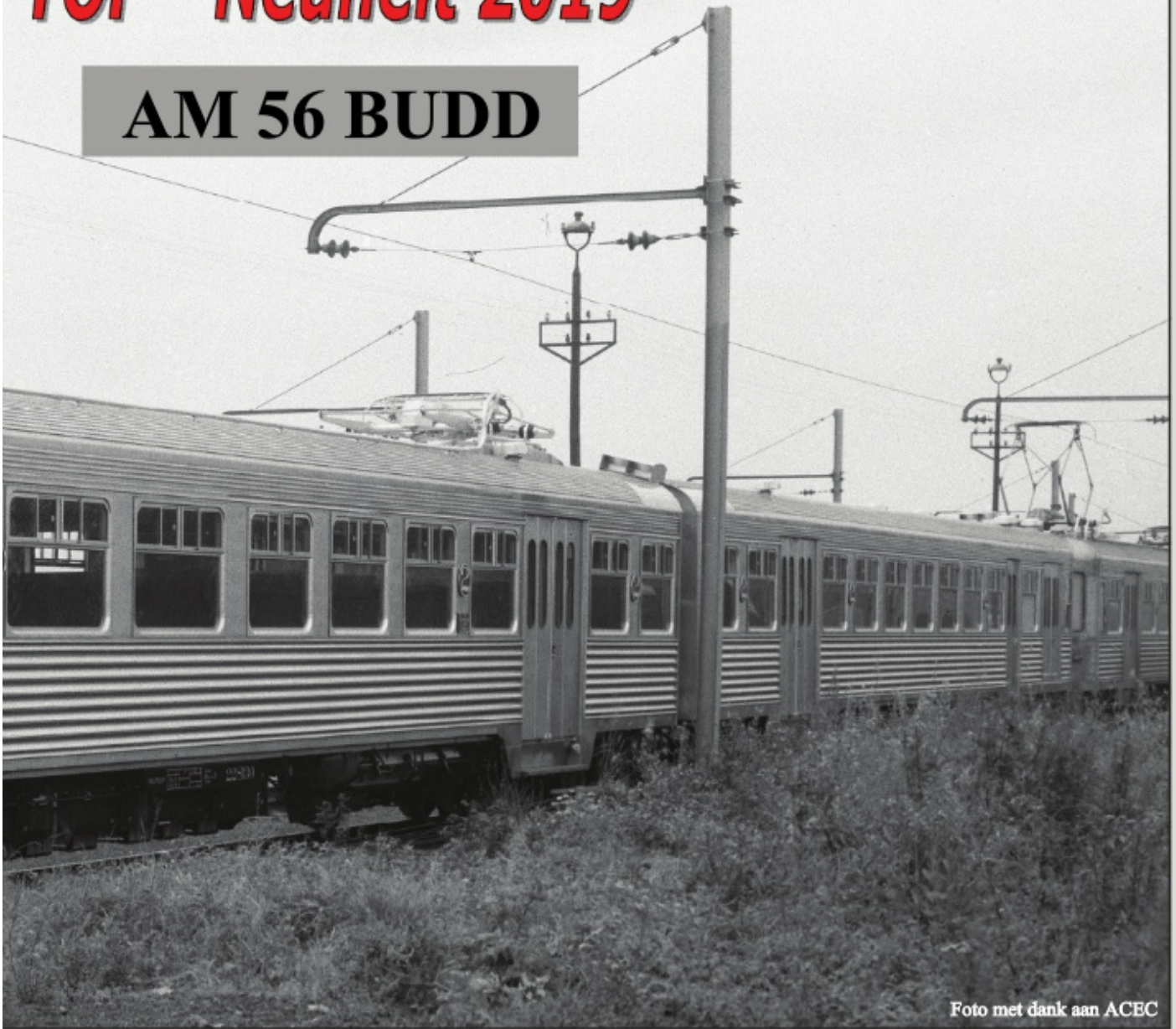

**NEW 19**

## AM 56 BUDD : version originale - ursprüngliche Version



Foto met dank aan ACEC

## AM 56 BUDD : model number 130

Ep. III

Version			Versie		
<b>7101.01</b>	<i>2-Rails = CC</i>	Courant continu	<b>7101.01</b>	<i>Gelijkstroom DC</i>	conventioneel
<b>7101.02</b>	"	Courant continu digital	<b>7101.02</b>	"	Digitaal
<b>7101.03</b>	"	CC digital SOUND	<b>7101.03</b>	"	Digitaal Sound

Version			Versie		
<b>7101.04</b>	<i>pour Märklin*</i>	Digital Mfx	<b>7101.04</b>	<i>voor Märklin*</i>	Digitaal Mfx
<b>7101.05</b>	"	Digital SOUND Mfx	<b>7101.05</b>	"	Dig.SOUND Mfx



## Formneuheit

### OPTIE 1 :

- dubbele, wisselende cabineverlichting
- interieurverlichting in beide rijtuigen
- geïntegreerde Powerpack
- extra schakelbare functies van de interieurverlichting (effecten)

### OPTION 1 :

- double éclairage cabine
- éclairage d'intérieur - dans les 2 wagons
- avec Powerpack
- fonctions supplémentaires d'éclairage intérieur

### OPTION 1 :

- changing cabine lights
- interior lights in both carriages
- integrated Powerpack
- extra switchable functions of interior lights (effects)



AM 86 : order nr VB-4005

NEW 19



Versie met blauwe lijn op de zijkant / version avec ligne bleue sur le côté

Nr 918 : with blue marking line on the side



Version			Versie		
VB-4005.02	<i>pour Märklin*</i>	Digital Mfx	VB-4005.02	<i>voor Märklin*</i>	Digitaal Mfx
VB-4005.04	"	Digital SOUND Mfx	VB-4005.04	"	Dig.SOUND Mfx

VB-4005.05	<i>2-Rails = CC</i>	Courant continu	VB-4005.05	<i>Gelijkstroom DC</i>	conventioneel
VB-4005.06	"	Courant continu digital	VB-4005.06	"	Digitaal
VB-4005.07	"	CC digital SOUND	VB-4005.07	"	Digitaal Sound

**OPTIE 1 :** dubbele, wisselende cabineverlichting + verlichting in de rijtuigen

**OPTION 1 :** double éclairage cabine + éclairage d'intérieur



NEW 19

Order nr : VB-3304 / Loc 2206



Loc 2206  
geel-blauw  
4 lichten  
Volle blauwe band !  
stelplaats St. Ghislain  
Epoche IV

Loc 2206  
Gelb-blau  
4 Frontlampen  
Mit großem blauem Band  
BW: St. Ghislain  
Epoche IV.

Loc 2206  
Jaune-bleue  
4 phares.  
Avec large bande bleue  
Dépôt: St. Ghislain  
Epoque IV

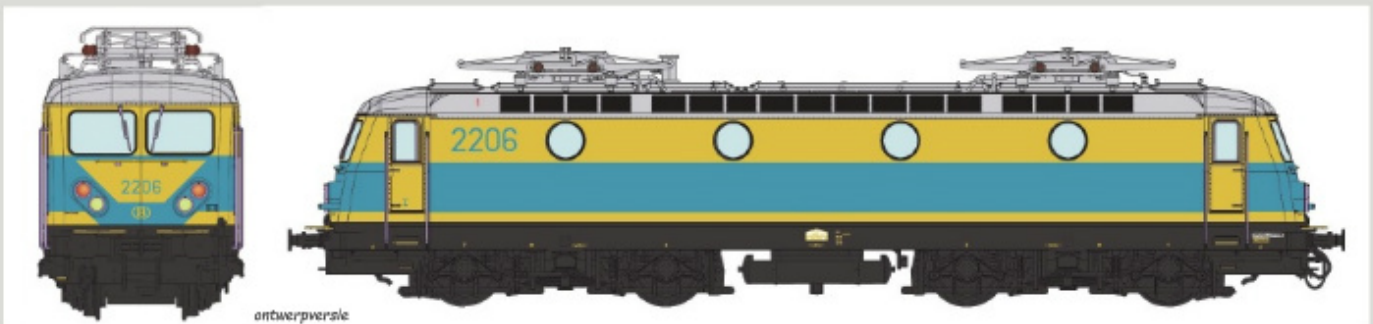

Version			Versie		
VB-3304.02	<i>pour Märklin*</i>	CA Digital Mfx	VB-3304.02	<i>voor Märklin*</i>	AC Digitaal Mfx
VB-3304.04	"	CA Digital SOUND Mfx	VB-3304.04	"	AC Dig.SOUND Mfx

VB-3304.05	<i>2-Rails = CC</i>	Courant continu	VB-3304.05	<i>Gelijkstroom DC</i>	conventioneel
VB-3304.06	"	Courant continu digital	VB-3304.06	"	Digitaal
VB-3304.07	"	CC digital SOUND	VB-3304.07	"	Digitaal Sound

Order nr : VB-3305 / Loc 2242

5 phares - 5 lichten

NEW 19

Formneuheit

Loc 2242

Blauw  
**5 lichten**  
 Met B-logo  
 stelplaats Merelbeke  
 Epoche IV

Loc 2242

Blau  
**5 Frontlampen**  
 Mit B-Logo  
 BW: Merelbeke  
 Epoche IV.

Loc 2242

Bleue  
**5 phares**  
 Avec logo B  
 Dépôt: Merelbeke  
 Epoque IV



Version			Versie		
VB-3305.02	<i>pour Märklin*</i>	CA Digital Mfx	VB-3305.02	<i>voor Märklin*</i>	AC Digitaal Mfx
VB-3305.04	"	CA Digital SOUND Mfx	VB-3305.04	"	AC Dig.SOUND Mfx

VB-3305.05	<i>2-Rails = CC</i>	Courant continu	VB-3305.05	<i>Gelijkstroom DC</i>	conventioneel
VB-3305.06	"	Courant continu digital	VB-3305.06	"	Digitaal
VB-3305.07	"	CC digital SOUND	VB-3305.07	"	Digitaal Sound

5 phares - 5 lichten

Order nr : VB-3306 / Loc 2249

Loc 2249

Groen

**5 lichten**

stelplaats Brussel Zuid

Epoche IV

Loc 2249

Grün

**5 Frontlampen**

BW: Brüssel-Midi.

Epoche IV.

Loc 2249

Verte

**5 phares**

Dépôt: Bruxelles-Midi

Epoche IV



Version			Versie		
VB-3306.02	<i>pour Märklin*</i>	CA Digital Mfx	VB-3306.02	<i>voor Märklin*</i>	AC Digitaal Mfx
VB-3306.04	"	CA Digital SOUND Mfx	VB-3306.04	"	AC Dig.SOUND Mfx

VB-3306.05	<i>2-Rails = CC</i>	Courant continu	VB-3306.05	<i>Gelijkstroom DC</i>	conventioneel
VB-3306.06	"	Courant continu digital	VB-3306.06	"	Digitaal
VB-3306.07	"	CC digital SOUND	VB-3306.07	"	Digitaal Sound

Order nr : VB-3205 / Loc 2507

NEW 19

Loc 2507

blauw  
4 lichten  
Met B-logo  
stelplaats Brussel Zuid  
Epoche IV

Loc 2507

blau  
4 Frontlampen  
Mit B-Logo  
BW: Brüssel-Midi.  
Epoche IV.

Loc 2507

bleue  
4 phares.  
Avec logo B  
Dépôt: Bruxelles-Midi  
Epoche IV



Version			Versie		
VB-3205.02	<i>pour Märklin*</i>	CA Digital Mfx	VB-3205.02	<i>voor Märklin*</i>	AC Digitaal Mfx
VB-3205.04	"	CA Digital SOUND Mfx	VB-3205.04	"	AC Dig.SOUND Mfx

VB-3205.05	<i>2-Rails = CC</i>	Courant continu	VB-3205.05	<i>Gelijkstroom DC</i>	conventioneel
VB-3205.06	"	Courant continu digital	VB-3205.06	"	Digitaal
VB-3205.07	"	CC digital SOUND	VB-3205.07	"	Digitaal Sound

Internationale versie : Nederland - Belgie - Frankrijk  
 Version internationale : Pays-Bas - Belgique - France

Order nr : VB-3105 / Loc 25.5



### VB-3105 : Loc 2556

- Blauw met onderbroken gele band
- met fabrieksplaat en UIC stekker
- Stelplaats : Brussel Zuid
- Tijdperk IV

### VB-3105 : Loc 2556

- Bleue avec ligne jaune.
- avec de plaque d'usine et UIC
- Dépot : Brussel Zuid
- Epoche IV



Version			Versie		
VB-3105.02	<i>pour Märklin*</i>	CA Digital Mfx	VB-3105.02	<i>voor Märklin*</i>	AC Digitaal Mfx
VB-3105.04	"	CA Digital SOUND Mfx	VB-3105.04	"	AC Dig.SOUND Mfx

VB-3105.05	<i>2-Rails = CC</i>	Courant continu	VB-3105.05	<i>Gelijkstroom DC</i>	conventioneel
VB-3105.06	"	Courant continu digital	VB-3105.06	"	Digitaal
VB-3105.07	"	CC digital SOUND	VB-3105.07	"	Digitaal Sound

## Ⓑ - models



Swiss loco G 2000 : Scheuchzer - Rhino 2

**Limitierte Auflage - nur 99 Stück - mit nummeriertem Zertifikat**

Version		
<b>3036.01</b>	2-Rails = CC	Courant continu
<b>3036.02</b>	"	Courant continu digital
<b>3036.03</b>	"	CC digital SOUND

Version		
<b>3036.04</b>	<i>pour Märklin*</i>	Digital Mfx
<b>3036.05</b>	"	Digital SOUND Mfx

**NEW 19**

**Rhino 2**



**NEW sound decoder from ESU V4/M4/Railcom + with original GM sound ! and more than 20 functions !**  
 Digital versions with **Power Pack**. Sound versions with the ESU smoke generator system

If you want a digital version, please order directly this version. The DC normal version can't be modified / upgraded to a digital or digital Sound version because of the Power Pack

### Artikel VB-9214 : CFL loc 1604 with 3 lights



VB-9214.01 DC =

VB-9214.02 DC = Digital

VB-9214.03 DC = dig.Sound

VB-9214.04 AC ~ Digital

VB-9214.05 AC ~ dig.Sound

### Artikel VB-9206 : TMY 1150 Railcare



VB-9206.01 DC =

VB-9206.02 DC = Digital

VB-9206.03 DC = dig.Sound

VB-9206.04 AC ~ Digital

VB-9206.05 AC ~ dig.Sound

Sound versie = with Dynamic Smoke System and Free Power Pack

**LIEFERBAR !**

With sound decoder from ESU V4/M4/Railcom + with original NOHAB sound ! and more than 20 functions !

**ESU SOUND decoder + Powerpack + the ESU smoke generator system**

Artikel VB-9207 : SNCB / NMBS loc 5404 with 5 lights

2<sup>o</sup> production



VB-9207.01 DC =

VB-9207.02 DC = Digital

VB-9207.03 DC = dig.Sound

VB-9207.04 AC - Digital

VB-9207.05 AC - dig.Sound

Artikel VB-9212 : Lollandsbanen M 38



VB-9212.01 DC =

VB-9212.02 DC = Digital

VB-9212.03 DC = dig.Sound

VB-9212.04 AC - Digital

VB-9212.05 AC - dig.Sound

Artikel VB-9213 : DSB 21105



VB-9213.01 DC =

VB-9213.02 DC = Digital

VB-9213.03 DC = dig.Sound

VB-9213.04 AC - Digital

VB-9213.05 AC - dig.Sound



NMBS 5512 New Look

NEW 19



Laatste kans voor een diesel 55 new look versie te reserveren !!

*Dernière chance de réserver une loco diesel 55 en couleur new look !!*



Version			Versie		
<b>20.127</b>	2-Rails = CC	Courant continu	<b>20.127</b>	Gelijkstroom DC	conventioneel
<b>20.827</b>	"	Courant continu digital	<b>20.827</b>	"	Digitaal
<b>21.127</b>	"	CC digital SOUND	<b>21.127</b>	"	Digitaal Sound

Version			Versie		
<b>22.127</b>	pour Märklin*	Digital Mfx	<b>22.127</b>	voor Märklin*	Digitaal Mfx
<b>23.127</b>	"	Digital SOUND Mfx	<b>23.127</b>	"	Dig.SOUND Mfx

# B - models

NMBS 5517 ATB + PZB 90 : ijzeren Rijn-loc

NEW 19



Version			Versie		
20.128	2-Rails = CC	Courant continu	20.128	Gelijkstroom DC	conventioneel
20.828	"	Courant continu digital	20.828	"	Digitaal
21.128	"	CC digital SOUND	21.128	"	Digitaal Sound

Version			Versie		
22.128	pour Märklin*	Digital Mfx	22.128	voor Märklin*	Digitaal Mfx
23.128	"	Digital SOUND Mfx	23.128	"	Dig.SOUND Mfx

**CFL 1810**

20.208 DC =  
 20.908 DC = digital  
 21.208 DC = digit.Sound

22.208 AC ~ digital  
 23.208 AC ~ digit.Sound

**NEW 19**

Ep IV

Depot Luxembourg

**CFL 1802 / Sweden**

20.209 DC =  
 20.909 DC = digital  
 21.209 DC = digit.Sound

22.209 AC ~ digital  
 23.209 AC ~ digit.Sound

**NEW 19**

Artikel VB-9305 : Loc n° 201.031 , Depot Haine St. Pierre

Ep. III

PROTOTYPE



VB-9305.01 DC =

VB-9305.02 DC = Digital

VB-9305.03 DC = dig.Sound

VB-9305.04 AC ~ Digital

VB-9305.05 AC ~ dig.Sound

Digital versions = Power Pack inclusive !

Artikel VB-9306 : Loc n° 5919 , Depot Antwerpen Dam

Ep. IV



PROTOTYPE

**Gele versie met brede groene band ! - Version avec large bande verte !**

VB-9306.01 DC =

VB-9306.02 DC = Digital

VB-9306.03 DC = dig.Sound

VB-9306.04 AC ~ Digital

VB-9306.05 AC ~ dig.Sound

Digital versions = Power Pack inclusive !

Artikel VB-9307 : Loc n° 201.038 , Depot Antwerpen Dam

Ep. III

NEW 19



PROTOTYPE

VB-9307.01 DC =

VB-9307.02 DC = Digital

VB-9307.03 DC = dig. Sound

VB-9307.04 AC ~ Digital

VB-9307.05 AC ~ dig. Sound

Digital versions = Power Pack inclusive !

If you want a digital version, please order directly this version. The DC normal version can't be modified / upgraded to a digital or digital Sound version because of the Power Pack



21

## *Diesel Loc 62 INFRABEL - met 5 lichten !*



## *Diesel Loco 62 INFRABEL - avec 5 phares !*

Version		Versie
<b>VB-9116.01</b>	<i>2-Rails = CC</i> Courant continu	<b>VB-9116.01</b> <i>Gelijkstroom DC</i> conventioneel
<b>VB-9116.02</b>	" Courant continu digital	<b>VB-9116.02</b> " Digitaal
<b>VB-9116.03</b>	" CC digital SOUND	<b>VB-9116.03</b> " Digitaal Sound

Version		Versie
<b>VB-9116.04</b>	<i>pour Märklin*</i> Digital Mfx	<b>VB-9116.04</b> <i>voor Märklin*</i> Digitaal Mfx
<b>VB-9116.05</b>	" Digital SOUND Mfx	<b>VB-9116.05</b> " Dig.SOUND Mfx

# Diesel 90 - 91

VB-5006 : Loc 9117 , depot St. Ghislain

Ep. IV



The " BELGIUM BIG BOY " : with SOUND and Power Pack !

Versies	systeem		Versions	systeem
VB-5006.01	DC		VB-5006.01	2-rail Courant Continu
VB-5006.02	DC digital		VB-5006.02	2-rail CC digital
VB-5006.03	DC digital SOUND		VB-5006.03	2-rail CC digital SON
VB-5006.04	AC dig (mfx)		VB-5006.04	AC dig (mfx)
VB-5006.05	AC dig (mfx) SOUND		VB-5006.05	AC dig (mfx) SON

# Diesel 90 - 91

Das Modell verfügt als standard über eine LED Beleuchtung.  
Standard LED Lichtwechsel rot/weiss.

Feine Details, mit Messingteile.  
Komplett bedruckt, mit scharf gezogenen Linien.  
Digital mit Powerpack !

Le modèle possède un éclairage intérieur LED de série.  
Inversion des feux LED rouge/blanc de série.  
Avec éclairage cabine (digital)

Haute finition des détails, avec des pièces en laiton.  
Complètement lettré avec des lignes très fines  
Version digital avec Powerpack !

**VB-5007 : Loc 9136 \* verlengde versie / plate-forme agrandie / long chassis \***

**NEW 19**

**Formneuheit**



Stelplaats : Merelbeke

Ep. V

Versies	system		Versions	system
VB-5007.01	DC		VB-5007.01	2-rail Courant Continu
VB-5007.02	DC digital		VB-5007.02	2-rail CC digital
VB-5007.03	DC digital SOUND		VB-5007.03	2-rail CC digital SON
VB-5007.04	AC dig (mfx)		VB-5007.04	AC dig (mfx)
VB-5007.05	AC dig (mfx) SOUND		VB-5007.05	AC dig (mfx) SON



# Diesel / rangeerlokje NMBS 90 - 91

## AC versions only for Märklin C-rails !

Model standaard uitgerust met LED verlichting  
Wit/rode wisselende lichten  
Cabine verlichting (digitaal)

Fijne details en messing onderdelen  
Alles bedrukt en scherpe belijning  
Digitale versie met Powerpack !

**VB-5008 :** Loc 9119 , depot Schaarbeek

Ep. IV



Versies	system		Versions	system
VB-5008.01	DC		VB-5008.01	2-rail Courant Continu
VB-5008.02	DC digital		VB-5008.02	2-rail CC digital
VB-5008.03	DC digital SOUND		VB-5008.03	2-rail CC digital SON
VB-5008.04	AC dig (mfx)		VB-5008.04	AC dig (mfx)
VB-5008.05	AC dig (mfx) SOUND		VB-5008.05	AC dig (mfx) SON

Wagen

-

Wagons

-

Cars

45.222 - Set A : 2 erts-wagons 'COCKERILL SAMBRE' NMBS / SNCB

Ep. V-VI

45.223 - Set B : zoals set A maar met andere wagonnummers



45.232 - Set A : 2 erts-wagons 'HAINAUT SAMBRE' NMBS / SNCB

Ep. IV

45.233 - Set B : zoals set A maar met andere wagonnummers



45.234 - Set A : 2 erts-wagons 'S.A. COCKERILL' NMBS / SNCB

Ep. IV

**NEW 19**

45.235 - Set B : zoals set A maar met andere wagonnummers



## Ⓑ - models



Der bekannte Getreidewagen von B-Models ist der einzige der auch in Miniatur die an der Seite typischen Schweißnähte besitzt. Beide Packungen A und B gibt es mit vier unterschiedlichen Betriebsnummern.

45.340 - Set A : set of 2 grain hopper cars ' VTG' D-VTGD

45.341 - Set B : like set A but with different car numbers

**LIEFERBAR !**



45.346 - Set A : Coffret de 2 wagons céréaliers ' Granit Service ' F-GRSE

Ep. VI

45.347 - Set B : comme coffret A mais avec autres numéros d'immatriculation

33 RIV  
87 F - GRSE  
9335 256-2



45.348 - Set A : set van 2 graan wagons ' TMF-CITA Ermewa ' SNCF

Ep. VI

45.349 - Set B : likomme coffret A mais avec autres numéros d'immatriculation



45.350 - Set A : Coffret de 2 wagons céréaliers 'Coopagri-Bretagne' SNCF

Ep. IV

45.351 - Set B : comme coffret A mais avec autres numéros d'immatriculation

**NEW 19**



54.107 - NMBS B-Cargo, groen, beladen met 2x 20ft Tankcontainer TAL



PROTOTYPE

54.108 - SNCB B-ERR, blue, chargé avec 2x 20ft conteneur citerne Gruber



PROTOTYPE

54.109 - CH-SBB, grau mit SBB Cargo logo, beladen mit 2x 20ft Tankcontainer Bertschi (blau)



PROTOTYPE

54.151 - D-ERMD, grau mit Ermewa logo, beladen mit 2 x 30ft Bulkcontainer Bulkhaul





29

**Sgns wagon A-ÖBB , beladen mit containers ‘ Koks - Kohle ‘**

Ref n° 90.800.1 : Wagon 1  
 90.800.2 : Wagon 2, like wagon 1 but with other car and container numbers

**Sgns wagon A-RCW , beladen mit containers ‘ Innofreight - Captrain ‘**

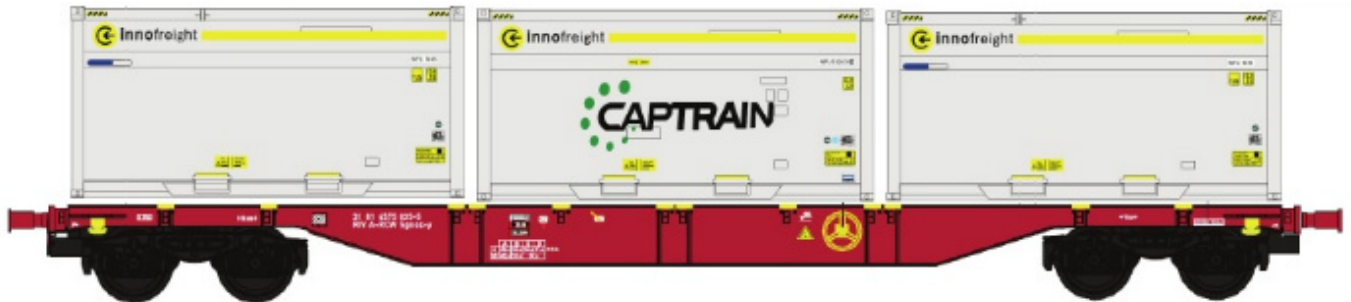
Ref n° 90.801.1 : Wagon 1  
 90.801.2 : Wagon 2, like wagon 1 but with other car and container numbers

**Sgns wagon SBB-Cargo , beladen mit containers ‘ Innofreight - SBB Cargo ‘**

Ref n° 90.804.1 : Wagon 1  
 90.804.2 : Wagon 2, like wagon 1 but with other car and container numbers

**NEW 19**

### Sgns wagon SBB-Cargo , beladen mit containers ‘ Innofreight - Stallinger Swiss Timber ‘

Ref n° 90.805.1 : Wagon 1  
90.805.2 : Wagon 2, like wagon 1 but with other car and container numbers

**NEW 19**



### Sgns wagon D-AAEC , beladen mit containers ‘ Fortum ‘

Ref n° 90.802.1 : Wagon 1  
90.802.2 : Wagon 2, like wagon 1 but with other car and container numbers  
90.802.3 : Wagon 3, like wagon 1 but with other car and container numbers

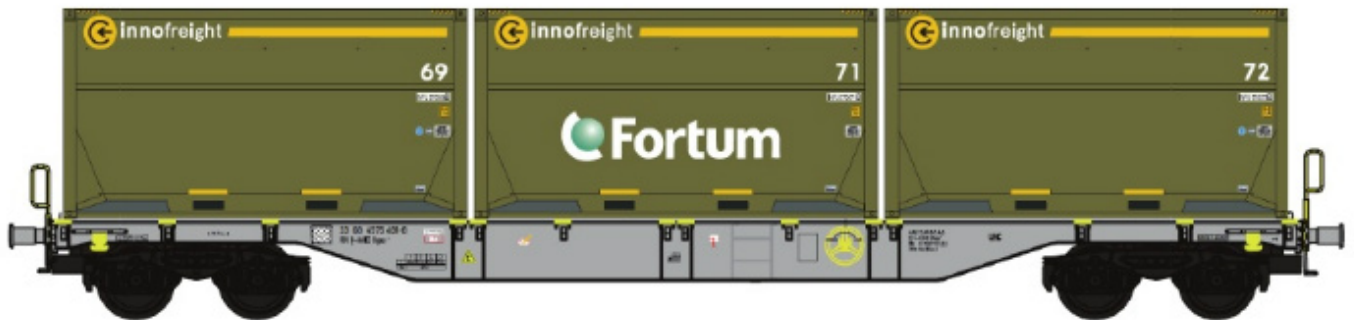

### Sgns wagon D-AAEC , beladen mit containers ‘ Green Cargo ‘

Ref n° 90.803.1 : Wagon 1  
90.803.2 : Wagon 2, like wagon 1 but with other car and container numbers

**NEW 19**



**B** - models

**innofreight**

Ref n° : 90.113 Set InnoWaggon wagens, beladen mit 4 Montainers ' 7 Sev.en / CD Cargo '

**NEW 19**



*Rerun - new numbers*

Ref n° : 90.216 Set InnoWaggon wagens, RockTainer ORE - SZ Cargo / Cinkarna

**NEW 19**



*Rerun - new numbers*

**\*\*\* Congratulations \*\*\* 1000 InnoWaggon \*\*\***

**NEW 19**





Ref n° : 90.114 Set FinnoWaggon (Finland) wagens ' VR Transpoint '

NEW 19



Rerun - new numbers

Ref n° : 90.451 Set InnoWaggon wagens, VTG cars, transport of Roundwood

NEW 19



Celebration model Ref n° : 90.115

NEW 19



## Ⓑ - models

Ref. 54.204 Set A : with 3 wood loaded Sgns cars D-AAEC : Rush Rail

54.205 Set B : same as set A but with other car numbers

NEW 19

RUSH RAIL



9 Timber Bunks painted and PRINTED with Rush Rail

Loaded with real wood !



34

Ref. 54.206 Set A : same Rush Rail cars but now with car numbers on grey box !

54.207 Set B : same as set A but with other car numbers

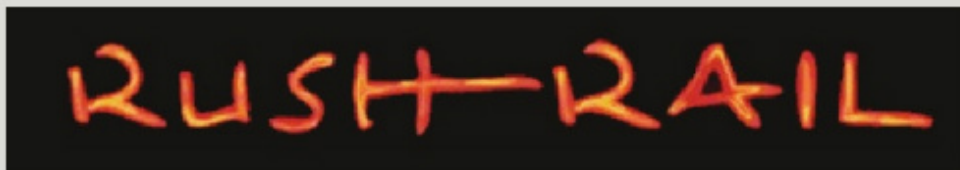

NEW 19



9 Timber Bunks painted and PRINTED with Rush Rail

Loaded with real wood !



**B** - models

# METAL EDITION

## Container cars Sggmrss 90

Die B-Models Modelle haben metallene Rahmen, dadurch haben die Wagen ein ausreichendes Eigengewicht um ein problemloses fahren auf der Anlage zu gewährleisten .

*The scale models of these wagons that B-Models makes have metal frames, so they are heavy enough to be used unloaded.*

De modellen van B-Models zijn uitgevoerd in metaal, zodat ze zwaar genoeg zijn om ook als lege wagen in een trein te rijden.

**55.102 Hupac, lichtgrijs met Hupac logo, opschrift CH-HUPAC, beladen met 2x 45f container Ge-eX**



**59.101 Touax, braun mit gelbem DHL Logo, B-TOUAX Beschriftung, beladen mit 2x 45ft Container DHL**

ausverkauft









**Metal Frame**







## Ⓑ - models







-  55.100 - Crossrail, blauw, opschrift D-XRAIL, beladen met 2x 45ft container P&O Ferrymasters
-  55.100 - Crossrail, blau, D-XRAIL, beladen mit 2x 45ft Container P&O Ferrymasters
-  55.100 - Crossrail, blue, D-XRAIL, loaded with 2x 45ft container P&O Ferrymasters
-  55.100 - Crossrail, bleu, D-XRAIL, chargé avec 2x 45ft conteneur P&O Ferrymasters







-  55.103 - AAE Cargo, grijs, D-AAEC, geen huurdersopschriften, beladen met 1x 40ft koel container Maersk & 1x 40ft koel container Maersk Sealand
-  55.103 - AAE Cargo, grau, D-AAEC, keine Mieteranschriften, beladen mit 1x 40ft Kühlcontainer Maersk & 1x 40ft Kühlcontainer Maersk Sealand
-  55.103 - AAE Cargo, grey, D-AAEC, no rental inscriptions, loaded with 1x 40ft reefer container Maersk & 1x 40ft reefer container Maersk Sealand
-  55.103 - AAE Cargo, gris, D-AAEC, sans inscriptions locataire, chargé avec 1x 40ft frigo conteneur Maersk & 1x 40ft frigo conteneur Maersk Sealand

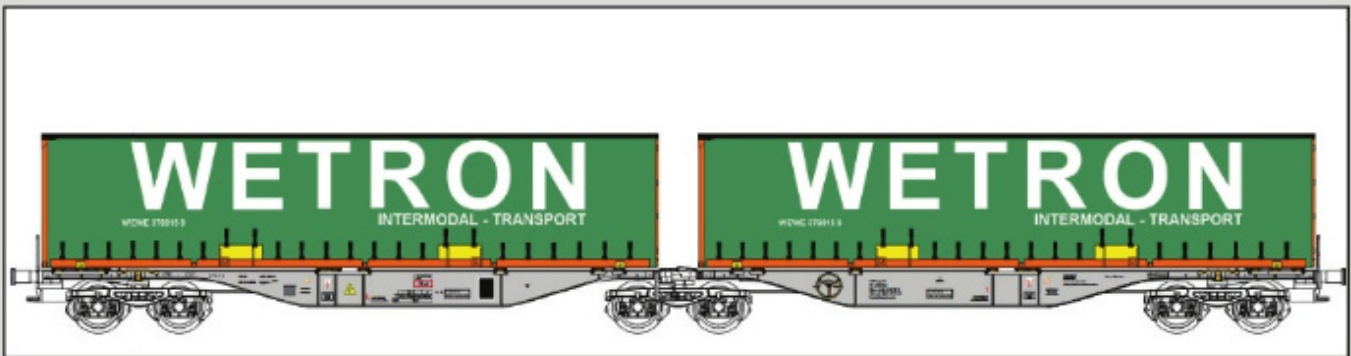





-  55.104 - AAE Cargo, verhuurd aan TRW, lichtgrijs met TRW logo, opschrift D-AAEC, beladen met 2x 45ft zeilwand container Ewals Cargo Care
-  55.104 - AAE Cargo, vermietet an TRW, hellgrau mit TRW Logo, Anschriften D-AAEC, beladen mit 2x 45ft Container mit Plane Ewals Cargo Care
-  55.104 - AAE Cargo, rented out to TRW, light grey with TRW logo, inscription D-AAEC, loaded with 2x 45ft tarp-side container Ewals Cargo Care
-  55.104 - AAE Cargo, loué à TRW, gris clair, avec logo TRW, inscription D-AAEC, chargé avec 2x 45ft bache conteneur Ewals Cargo Care







-  55.105 - AAE Cargo, lichtgrijs, verhuurd aan TX Logistiek, opschrift D-AAEC, beladen met 2x 45ft zeilwand container Wetron
-  55.105 - AAE Cargo, hellgrau, vermietet an TX Logistiek, Anschriften D-AAEC, beladen mit 2x 45ft Container mit Plane Wetron
-  55.105 - AAE Cargo, light grey, rented out to TX Logistiek, inscription D-AAEC, loaded with 2x 45ft tarp-side container Wetron
-  55.105 - AAE Cargo, gris clair, loué à TX Logistiek, inscription D-AAEC, chargé avec 2x 45ft bache container Wetron



-  59.100 - AAE Cargo, verhuurd aan IFB, lichtgrijs met IFB logo, opschrift D-AAEC, beladen met 2x 45ft container ECS
-  59.100 - AAE Cargo, vermietet an IFB, hellgrau mit IFB Logo, D-AAEC Beschriftung , beladen mit 2x 45ft Container ECS
-  59.100 - AAE Cargo, rented out to IFB, light grey with IFB logo, inscription D-AAEC, loaded with 2x 45ft container ECS
-  59.100 - AAE Cargo, loué à IFB, gris clair avec logo IFB, inscription D-AAEC, chargé avec 2x 45ft conteneur ECS











-  59.201 - AAE Cargo, verhuurd aan ERS, lichtgrijs, opschrift D-AAEC, beladen met 1x 45ft container Eucon & 1x 45ft container Containerships
-  59.201 - AAE Cargo, vermietet an ERS, hellgrau, D-AAEC Beschriftung , beladen mit 1x 45ft Container Eucon & 1x 45ft Container Containerships
-  59.201 - AAE Cargo, rented out to ERS, light grey, inscription D-AAEC, loaded with 1x 45ft container Eucon & 1x 45ft container Containerships
-  59.201 - AAE Cargo, loué à ERS, gris clair, inscription D-AAEC, chargé avec 1x 45ft conteneur Eucon & 1x 45ft conteneur Containerships

## Ⓑ - models

59.200 AAE Cargo, verhuurt an ERS, D-AAEC Beschriftung , beladen mit 2x 45ft Container Samskip



-  59.300 - Ambrogio, grijs met Ambrogio logo, opschrift I-AMBR, met 2x 45ft zeilwand container Ambrogio
-  59.300 - Ambrogio, grau mit Ambrogio Logo, I-AMBR Beschriftung , mit 2x 45ft Cont. mit Plane Ambrogio
-  59.300 - Ambrogio, grey with Ambrogio logo, inscription I-AMBR, with 2x 45ft tarp-side container Ambrogio
-  59.300 - Ambrogio, gris avec Ambrogio logo, inscription I-AMBR, avec 2x 45ft bache conteneur Ambrogio

-  59.301 - andere nummers
-  59.301 - unters. Betriebsn.
-  59.301 - other numbers
-  59.301 - d'autres numéros





59.200 AAE Cargo, loué à ERS, gris clair, inscription D-AAEC, chargé avec 2x 45ft conteneur Samskip



59.302 - Ambrogio, grijs met Ambrogio logo, opschrift I-AMBR, beladen met 2x 45ft container Ambrogio



59.302 - Ambrogio, grau mit Ambrogio Logo, I-AMBR Beschriftung, beladen mit 2x 45ft Container Ambrogio







59.302 - Ambrogio, grey with Ambrogio logo, inscription I-AMBR, loaded with 2x 45ft container Ambrogio

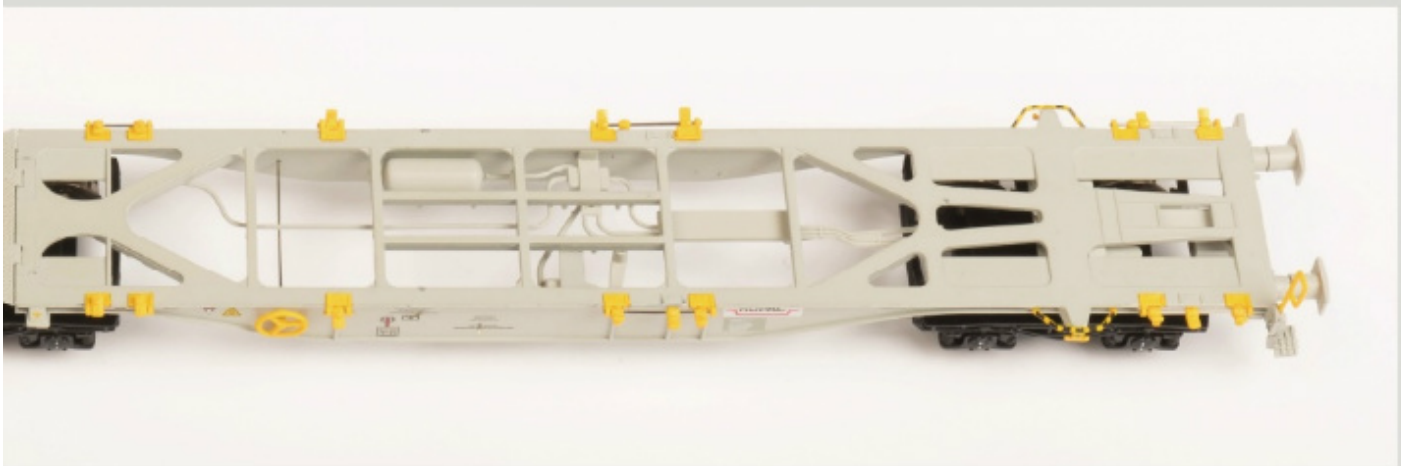





59.302 - Ambrogio, gris avec Ambrogio logo, inscription I-AMBR, chargé avec 2x 45ft conteneur Ambrogio







## Ⓑ - models

-  59.300 - Ambrogio, grijs met Ambrogio logo, opschrift I-AMBR, met 2x 45ft zeilwand container Ambrogio
-  59.300 - Ambrogio, grau mit Ambrogio Logo, I-AMBR Beschriftung , mit 2x 45ft Cont. mit Plane Ambrogio
-  59.300 - Ambrogio, grey with Ambrogio logo, inscription I-AMBR, with 2x 45ft tarp-side container Ambrogio
-  59.300 - Ambrogio, gris avec Ambrogio logo, inscription I-AMBR, avec 2x 45ft bache conteneur Ambrogio

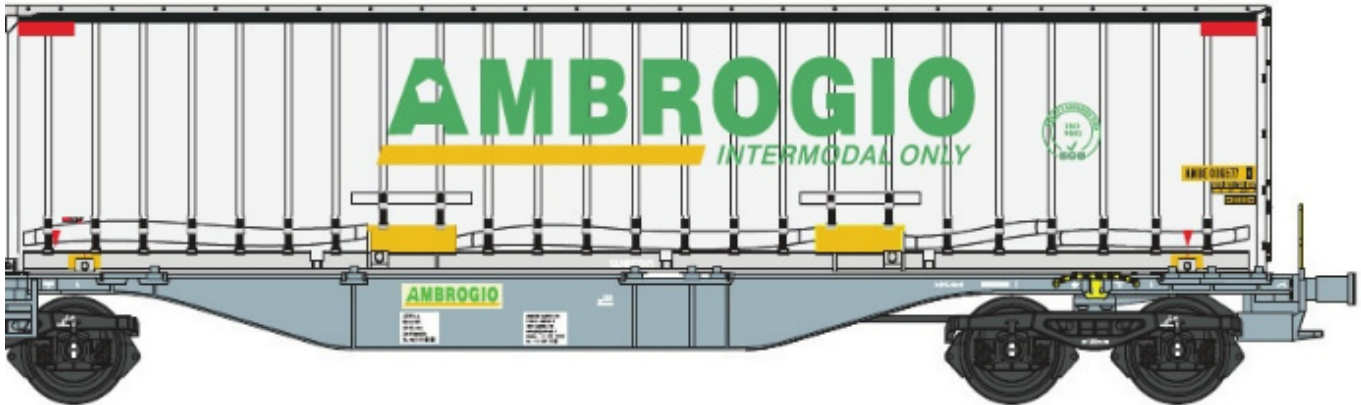
-  59.301 - andere nummers
-  59.301 - unters. Betriebsn.
-  59.301 - other numbers
-  59.301 - d'autres numéros





-  59.302 - Ambrogio, grijs met Ambrogio logo, opschrift I-AMBR, beladen met 2x 45ft container Ambrogio
-  59.302 - Ambrogio, grau mit Ambrogio Logo, I-AMBR Beschriftung , beladen mit 2x 45ft Container Ambrogio
-  59.302 - Ambrogio, grey with Ambrogio logo, inscription I-AMBR, loaded with 2x 45ft container Ambrogio
-  59.302 - Ambrogio, gris avec Ambrogio logo, inscription I-AMBR, chargé avec 2x 45ft conteneur Ambrogio



## Ⓑ - models

Artikel 92.104

# LIEFERBAR !



B-models Set 92.104 mit 3 SBB-Cargo Wagen, Serie 2 : 2 Seilanker



Artikel 92.105

LIEFERBAR !



B-models Set 92.105 mit 3 SBB-Cargo Wagen, Serie 2 : 2 Seilanker  
Version SBB-CFF mit Logo ' Schweizer Zucker '



# Ⓑ - models

Artikel 92.106

# LIEFERBAR !



Set mit 3 SBB-Cargo Wagen, Serie 2 : 2 Seilanker  
Version CH-SBBC mit Logo 'Zucker - Sucre - Zucchero '



Artikel 92.107 : Set mit 3 Wagen, Set 1

NEW 19

Artikel 92.108 : Set mit 3 Wagen, Set 2, mit neuen Betriebsnummern

NEW 19



Set met 3 wagens SBB-Cargo, 2° Serie : 2 gele haken  
 Versie CH-SBBC met rood logo 'CACAO' (Nederland/Belgie/Zwitserland)  
 (Niederlande / Belgien / Schweiz)



Set met 3 SBB-Cargo Wagen, Serie 2 : 2 Seilanker  
 Version CH-SBBC mit rotem Logo 'CACAO' (Niederlande / Belgien / Schweiz)

CACAO

The "CHOCOLATE TRAIN"

CACAO



designversion





## The new Sugar car of VTG

 Volledig nieuw ontwikkelde wagen, nog nooit op de markt gebracht in schaal HO : de Uagnpps wagen van VTG  
Deze wagen gebruikt men voor het vervoer van suiker en rijdt dagelijks in België (oa Antwerpen & Tiense Suiker)

 Völlig neu entwickelter Wagen, neu und noch nie im Maßstab H0 auf den Markt gebracht : Der Uagnpps-Wagen von VTG. Diese Wagen werden für den Transport von Zucker.



 Complete new development of this car type, this car is never be made before in scale HO : the Uagnpps car Of VTG. This car is dedicated to the transport of sugar.

 Nouveau développement entier d'un wagon jamais commercialisé à l'échelle HO: le wagon Uagnpps de VTG. Ce wagon est utilisé pour le transport de sucre.





Artikel 92.500

-  Set mit 3 Wagen, Ablieferungszustand, **Serie 1** - GKZ 9342 : Die ersten 40 Wagen (nr 014-053)
-  Set met 3 wagens , originele versie, **1° Serie** - GKZ 9342 : reeks van eerste 40 wagens (nr 014-053)
-  Box with 3 cars , Original version, **Serie 1** - GKZ 9342 : first production of 40 wagons (n° 014-053)
-  Coffret avec 3 wagons, version original, **1° Serie** - GKZ 9342 : 1°production de 40 wagons (014-053)





Artikel 92.501

Wagen nr : 37 80 9347 094-6  
 37 80 9347 096-1  
 37 80 9347 097-9

-  Set mit 3 Wagen, **Serie 2** - GKZ 9347, 200 Wagen : **Set 1**
-  Set met 3 wagens , **2° Serie** - GKZ 9347, 200 wagens : **Set 1**
-  Box with 3 cars , **Serie 2** - GKZ 9347, 200 wagens : **Box 1**
-  Coffret avec 3 wagons, **2° Serie** - GKZ 9347, 200 wagons : **Coffret 1**

Artikel 92.502

Wagen nr : 37 80 9347 104-3  
 37 80 9347 105-0  
 37 80 9347 117-5

-  Set mit 3 Wagen, **Serie 2** - GKZ 9347, 200 Wagen : **Set 2** , mit neuen Betriebsnummern
-  Set met 3 wagens , **2° Serie** - GKZ 9347, 200 wagens : **Set 2** , andere nummers vd wagens
-  Box with 3 cars , **Serie 2** - GKZ 9347, 200 wagens : **Box 2** , other car numbers
-  Coffret avec 3 wagons, **2° Serie** - GKZ 9347, 200 wagons : **Coffret 2** , avec autres numéros d'immatr.



## The new Sugar car of VTG



Ⓑ - models

Ⓑ - models



# Tads wagon NMBS - SNCB **B-cargo**

Ref. VB-83008 :

Set met 3 wagons, groen , **B-Cargo**

Coffret avec 3 wagons, vert , **B-Cargo**

**LIEFERBAR !**



# Tads wagon NMBS - SNCB X-pedys

Ref. VB-83009 :

Set met 3 wagons, groen , X-pedys

Coffret avec 3 wagons, vert , X-pedys

**LIEFERBAR !**



**B** - models

# Tads wagon B - CARGO **Trans Engrais**

Ref. VB-83010 :**NEW 19**

Set met 3 wagons, groen, B-cargo / TRANS ENGRAIS

Coffret avec 3 wagons, vert , **B-Cargo / TRANS ENGRAIS**

# Tads wagon B - ERSA Ermewa

Ref. VB-83011 :

NEW 19

Set met 3 wagons, grijs, B-Ersa / Ermewa (zoals 83007 maar met andere nummers)

Coffret avec 3 wagons, gris, B-Ersa / Ermewa (comme 83007 mais d'autres numéros)



# Set Colli wagons NMBS - SNCB

**Ref. 45.805 :**

Set NMBS, 3 colli wagens type Gkkims  
tijdperk IV

**NEW 19**

*Coffret SNCB, 3 colis wagons type Gkkims  
Epoque IV*





# Tremie Balastwagon NMBS - SNCB

**Ref. VB-84009 :**

Set NMBS, 3 balastwagens + belading,  
tijdperk IV - onderhoud door Saint-Ghislain

**NEW 19**

*Coffret SNCB, 3 wagons Tremie + chargement,  
Epoque IV - entretien par Saint-Ghislain*



## Tads Schwenkdachwagen D-NACCO

Ep. VI

**NEW 19**

 Ref. [VB-83201](#) : Set mit 3 Schwenkdachwagens Tads , gelb

Formneuheit

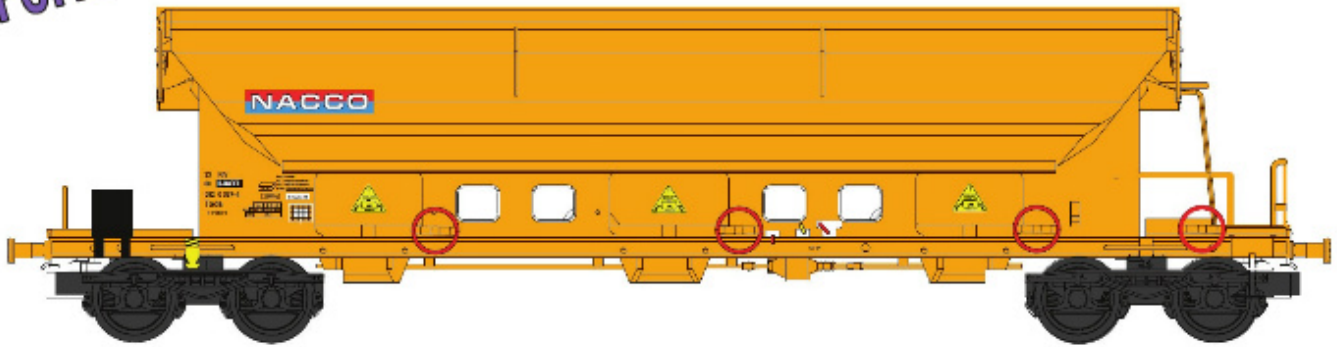
*Designversion*

## Tads Schwenkdachwagen DB NACCO

Ep. VI

**NEW 19**

 Ref. [VB-83202](#) : Set mit 3 Schwenkdachwagens Tads , blau / grün

Formneuheit

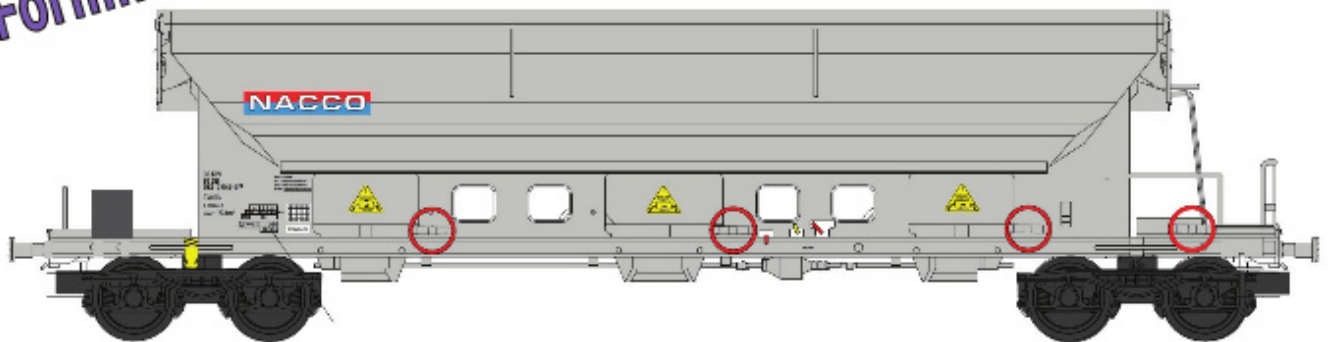
*Designversion*

# Tremie Balastwagon SNCF

Ref. VB-84204 :

Coffret SNCF, 3 wagons Tremie + chargement,  
Direction de l'équipement (SNCF / SNCB)

**LIEFERBAR !**



# Tremie Balastwagon SNCF

## Ref. VB-84205 :

Coffret SNCF, 3 wagons Tremie + chargement,  
Direction de l'équipement / TGV Mediterranee

Set SNCF, 3 balastwagens + belading,  
Direction de l'équipement / TGV Mediterranee

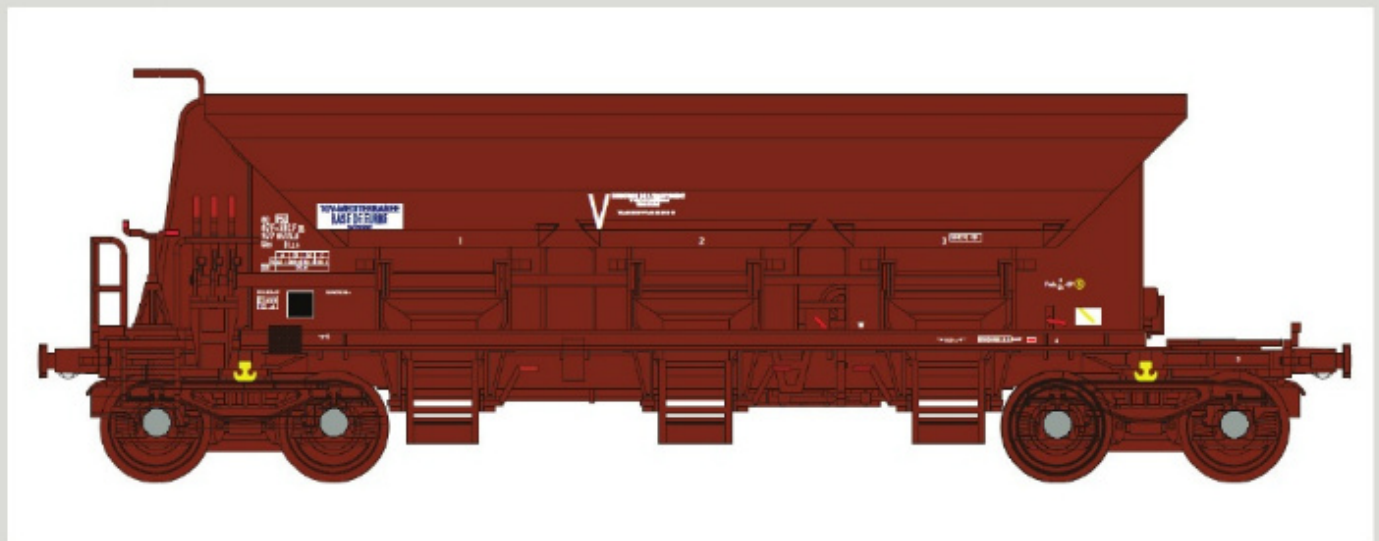

# Tremie Balastwagon SNCF

Ref. VB-84206 :

**NEW 19**

Coffret F-SNCF, 3 wagons Tremie + chargement,  
'INFRA V' (SNCF / SNCB)



Modern Knick-tankcar with detailed printings and spring buffers. Tankcar with real 'knick', also on platform  
 Moderne Knick-Kesselwagens mit detaillierte Bedruckung und Federpuffer, mit 'knick' am platform !



Set of 2 cars : 69,90 euro !  
 Set mit 2 wagons : 69,90 euro !



VB-81042 : Set 2 wagons '

Gatx DHL '

D-GATX



VB-81046 : Set 2 wagons ' CD Cargo '

CZ-CDCR



VB-81047 : Set 2 wagons ' Air Liquide '

SNCF

NEW 19



Alle verwijzingen naar andere merken of logo's in deze brochure zijn zuiver informatief. Dit enkel om de klant zo goed als mogelijk te informeren. Onder voorbehoud van wijzigingen en/of drukfouten.

VB-81048 : Set 2 wagons ' GATX ' gelb (kleines logo)

D-GATXD

NEW 19

*Rerun - new numbers*

VB-81049 : Set 2 wagons ' Wascosa JET A-1 '

CZ-WASCO

NEW 19

*Rerun - new numbers*

VB-81050 : Set 2 wagons ' Pannonia Ethanol '

CZ-WASCO

NEW 19



VB-81051 : Set 2 wagons ' Wascosa '

CZ-WASCO

NEW 19



Modern Knick-tankcar with detailed printings and spring buffers. Tankcar with real 'knick', also on platform  
 Moderne Knick-Kesselwagens mit detaillierte Bedruckung und Federpuffer, mit 'knick' am platform !



Set of 2 cars : 69,90 euro !  
 Set mit 2 wagons : 69,90 euro !



VB-81052 : Set 2 wagons ' GATX '

D-GATX

**NEW 19**



VB-81053 : Set 2 wagons ' L'Air Liquide '

SNCF

**NEW 19**



VB-81054 : Set 2 wagons ' Ermewa / Pannonia Ethanol '

CZ-ERMW

**NEW 19**



Alle verwijzingen naar andere merken of logo's in deze brochure zijn zuiver informatief. Dit enkel om de klant zo goed als mogelijk te informeren. Onder voorbehoud van wijzigingen en/of drukfouten.



# Trains for Fun

**Ref 9901 : Mc Donald's loco G2000 , depot Roeselare / Belgium**

Ep. VII

9901.01 DC =

9901.02 DC = digital

9901.03 DC = digit.Sound

9901.04 AC ~ digital

9901.05 AC ~ digit.Sound

NEW 19

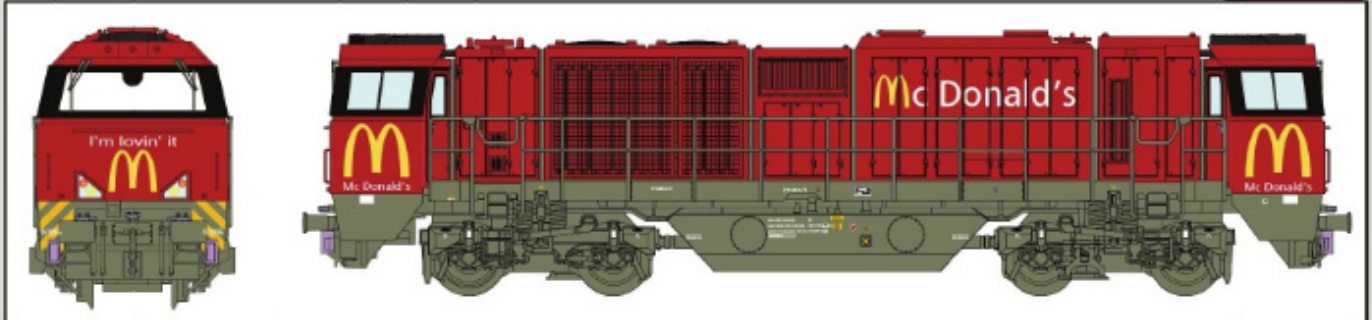

**Ref 9902 : INFRABEL loco G2000 + 3 wagons infrabel**

Ep. VII

9902.01 DC =

9902.02 DC = digital

9902.03 DC = digit.Sound

9902.04 AC ~ digital

9902.05 AC ~ digit.Sound

NEW 19

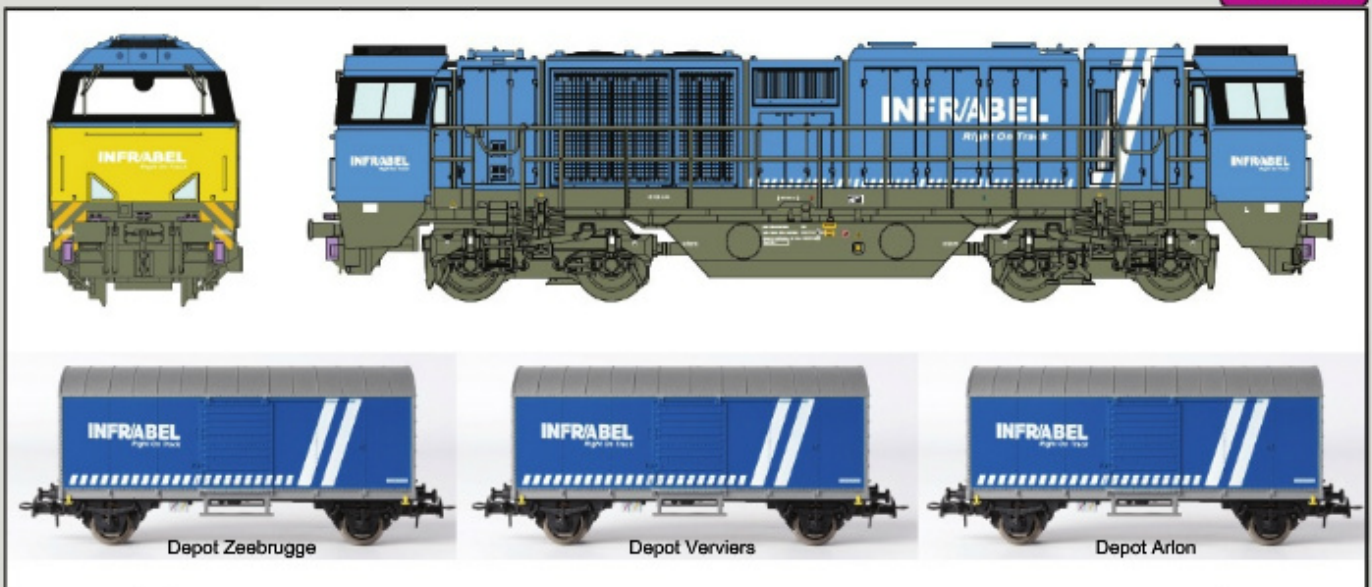

**Ref 9903 : Extra set met 3 wagons INFRABEL**

Ep. VII



www. Euro-Tank-Car .eu

# Spur 1 - 1:32 - Scale 1

Moderne Kesselwagens mit detaillierte Bedruckung mit 'knick' am platform !

Artikel : SP-1012 :

Knick-Kesselwagen ' GATX '

New car number !



Price : 279 euro

PREIS : 279 euro

Prijs : 279 euro

Artikel : SP-1022 :

Knick-Kesselwagen ' Wascosa '

New car number !



# Spur 1 - 1:32 - Scale 1

**Preisgünstig !**

· Klauenkupplung liegt bei

**Preisgünstig !**

Artikel : SP-1031 : Knick-Kesselwagen ' KVG '



limitiertes serie Nr 50 stück pro nummer

Artikel : SP-1061 : Knick-Kesselwagen ' Wascosa '

**New car 2019 !**



www. Euro-Tank-Car .eu

# Spur 1 - 1:32 - Scale 1

**Preisgünstig !**

· Klauenkupplung liegt bei

**Preisgünstig !**

Artikel : SP-1071 :

Knick-Kesselwagen ' GATX '

**New car 2019 !**



only 50 pcs of each !

**Price : 279 euro**

**PREIS : 279 euro**

**Prijs : 279 euro**

limitiertes serie Nr 50 stück pro nummer

Artikel : SP-1081 :

Knick-Kesselwagen ' Wascosa '

**New car 2019 !**



only 50 pcs of each !

# Spur 1 - 1:32 - Scale 1

Moderne Kesselwagens mit detaillierte Bedruckung mit 'knick' am platform !

Artikel : SP-1031 : Knick-Kesselwagen ' KVG '

Nur 50 Stück !



Artikel : SP-1031 : Knick-Kesselwagen ' KVG '

only 50 pcs of each !



Artikel : SP-1061 : Knick-Kesselwagen ' Wascosa '

Nur 50 Stück !



[www.B-models.be](http://www.B-models.be)

E-mail : [contact@b-models.be](mailto:contact@b-models.be)

[www.Euro-Tank-Car.eu](http://www.Euro-Tank-Car.eu)

[www.Budget-Line.com](http://www.Budget-Line.com)

[www.VanBiervliet.com](http://www.VanBiervliet.com)

© Van Biervliet. Brochure is zuiver informatief. Artikelen zolang de voorraad strekt en onder voorbehoud van wijzigingen en/of drukfouten.

Met dank aan de treinspotters en liefhebbers voor het mogen gebruiken van de mooie foto's.

Speciale dank aan : MC, KVDW, EP, KF, AV, PA, SD, PG, S en CC.

Verwijzingen naar andere merken of logo's zijn zuiver informatief. Dit enkel om de klant zo goed als mogelijk te informeren.

Deze brochure vervangt alle voorgaande. Brochure januari 2019. Design : Kristof