

H0

2019/20



PRODUKT- ÜBERSICHT

PRODUCT OVERVIEW



LOKS UND WAGEN IN SPUR H0
LOCOMOTIVES AND WAGONS IN GAUGE H0





ENTDECKEN SIE IHRE PERSÖNLICHEN LIEBLINGSMODELLE IN SPUR H0!

DISCOVER YOUR PERSONAL FAVOURITE
MODELS IN GAUGE H0!

D – Herzlich willkommen zu unserer neuen Produktübersicht in Spur H0! Auf über 80 Seiten stellen wir Ihnen das gesamte BRAWA Sortiment der Spurweite H0 vor. Unter den mehr als 100 Lokomotiven finden Sie echte Highlights wie z. B. die Dampflokom BR 01, die Ellok E44 oder die Diesellok V36. Wir wünschen viel Freude beim Entdecken Ihrer persönlichen Modellfavoriten!

EN – Welcome to our new product overview of the H0 gauge! We present the complete BRAWA H0 gauge range on more than 80 pages. Among the models, you will find real highlights, including the steam locomotive BR 01, electric locomotive E44 or the diesel locomotive V36. We hope you enjoy discovering your own favourite models!

YouTube



Besuchen Sie uns auf Youtube und entdecken Sie die digitalen Funktionen des BRAWA Twindexx Vario® IC2!

Visit our Youtube Channel and discover the digital functions of the BRAWA Twindexx Vario® IC2!



Lokomotiven	04	Locomotives
Dampflokomotiven	06	Steam Locomotives
Elektrolokomotiven	11	Electric Locomotives
Diesellokomotiven	18	Diesel Locomotives
Triebwagen	24	Railcars
Wagen	28	Wagons
Personenwagen	30	Passenger Coaches
Güterwagen	46	Freight Cars



AB SOFORT JÄHRLICH: VORFREUDE AUF LIEBE ZUM DETAIL

ANNUALLY, STARTING NOW:
ANTICIPATION OF LOVE FOR DETAIL



Die jährlich erscheinenden BRAWA Produktübersichten für H0 und N sowie den neuen Zubehörkatalog für beide Spurweiten erhalten Sie ab sofort bei Ihrem Fachhändler.

The annual BRAWA Product Overviews for H0 and N, as well as the new accessories catalogue for both gauges, are now available from your specialist dealer.

D – Mit der aktuellen Produktübersicht bietet Ihnen BRAWA ab sofort einen Gesamtüberblick über alle Loks, Personen- und Güterwagen. Durch ein neues Layout und die Trennung nach Spurweiten sind unsere Druckschriften deutlich kompakter aufgebaut und davon profitieren Sie. Die Ausgaben für Spur H0 und Spur N erscheinen nun **jährlich** und ersetzen den Hauptkatalog, der bisher alle zwei Jahre neu aufgelegt wurde. Ergänzend bieten wir Ihnen mit dem Zubehörkatalog eine Komplettübersicht über alle Zubehörprodukte in den Spurweiten H0 und N. Zusätzlich zu den neuen Produktübersichten erscheint natürlich auch in Zukunft zu Beginn jeden Jahres wie gewohnt der BRAWA Neuheitenprospekt.

Detaillierte Informationen zu den einzelnen Modellen finden Sie auf unserer Website, die Ihnen auch zahlreiche weitere Optionen bietet – von produktspezifischen Downloads über Videos und Sounddateien bis zu Empfehlungen für die Zusammenstellung epochengerechter Zugkombinationen.

EN – With the current product overview, BRAWA now offers you a complete round-up of all locomotives, passenger coaches and goods wagons. Due to a new layout and separation according to gauge, our printed material is much more compact, which benefits you. The issues for H0 gauge and N gauge are published **annually** and replace the main catalogue, which was previously reissued every two years. In addition, the accessories catalogue offers you a complete overview of all accessory products in gauges H0 and N. And in addition to the new product overviews, the BRAWA New Items Brochure will of course be published at the beginning of each year as usual.

Detailed information on the individual models can be found on our website, which also offers you numerous other options, from product-specific downloads to videos and sound files through to recommendations for putting together train combinations in a historically accurate manner.



ECHTER MEHRWERT: DIE BRAWA WEBSITE

REAL ADDED VALUE: THE BRAWA WEBSITE



- 01 AUSFÜHRLICHE INFORMATIONEN ZU DEN DETAILS DER MODELLVARIANTEN MIT ERLÄUTERUNG ALLER ICONS
COMPREHENSIVE INFORMATION ON THE DETAILS OF THE MODEL VARIANTS WITH EXPLANATION OF ALL ICONS
- 02 INFORMATIONEN ZUR AUSZEICHNUNG VON MODELEN
INFORMATION ON AWARDS, HONOURS AND DISTINCTIONS RECEIVED BY MODELS
- 03 AUSFÜHRLICHE BESCHREIBUNG DER MODELLEDETAILS UND DER ZUSATZFUNKTIONEN DER DIGITALEN VERSION
DETAILED DESCRIPTIONS OF THE MODEL DETAILS AND ADDITIONAL FUNCTIONS OF THE DIGITAL VERSION
- 04 FUNKTIONSÜBERSICHT DER MODELLVARIANTEN
FUNCTIONAL OVERVIEW OF THE MODEL VARIANTS
- 05 BEDIENUNGSANLEITUNGEN MIT ERSATZTEILLISTEN UND FUNKTIONSÜBERSICHTEN ZUM HERUNTERLADEN
OPERATING INSTRUCTIONS WITH SPARE PARTS LISTS AND FUNCTION OVERVIEWS FOR DOWNLOAD

- 06 KOMFORTABLES "SPRUNGMENÜ" ZUR SCHNELLEREN NAVIGATION
CONVENIENT "GOTO MENU" FOR FASTER NAVIGATION
- 07 INFORMATIONEN UND FOTOS ZU DEN VORBILDERN UNSERER MODELLE
INFORMATION ABOUT AND PHOTOS OF THE REAL STOCK OUR MODELS ARE BASED ON
- 08 ÜBERSICHTLICHE AUFLISTUNG WEITERER MODELLE DER GLEICHEN BAUREIHE
CLEARLY ARRANGED LISTS OF ADDITIONAL MODELS OF THE SAME SERIES
- 09 INFORMATIVE PRODUKT- ODER WERKSTATTVIDEOS
INFORMATIVE PRODUCT AND WORKSHOP VIDEOS
- 10 PRODUKTEMPFEHLUNGEN FÜR DIE EPOCHENGERECHTE ZUSAMMENSTELLUNG EINES ZUGES
PRODUCT RECOMMENDATIONS FOR ASSEMBLING TRAINS IN A HISTORICALLY ACCURATE MANNER





LOKOMOTIVEN

LOCOMOTIVES

Dampflokomotiven	06	Steam Locomotives
Elektrolokomotiven	11	Electric Locomotives
Diesellokomotiven	18	Diesel Locomotives
Triebwagen	24	Railcars



DAMPFLOKOMOTIVE BR 01 DER DRG

STEAM LOCOMOTIVE BR 01 DRG

MASSSTÄBLICHER ABSTAND ZWISCHEN
LOKOMOTIVE UND TENDER
SCALE DISTANCE BETWEEN LOCOMOTIVE AND TENDER

FAHRWERK BELEUCHTET
ILLUMINATED UNDERCARRIAGE

LAUTSPRECHER IN DER RAUCHKAMMER
EINGEBAUT (NUR BEI DIGITAL EXTRA)
SPEAKER INSTALLED IN THE SMOKE CHAMBER
(DIGITAL EXTRA ONLY)



Best.-Nr. Order no. **40900** Analog BASIC+ 20 Digital BASIC+ 20 D&H **40901*** Digital EXTRA 20 D&H **40902*** Digital EXTRA 20 D&H **40903*** Digital EXTRA 20 D&H

Betriebs-Nr. | Road no.: 01 193

*40901+40902+40903: werkseitig ausverkauft | sold out

Abb. zeigt Handmuster | Picture show layout version

D – Erst recht spät, 1936/37 erhält die Rbd Köln für den Verkehr am Rhein die Loks 01 192 – 198 zugewiesen. 01 193 wird am 21.12.36 abgenommen und dem Bw Deutzerfeld zugewiesen. In den Aufgabenbereich der Loks fällt auch die Bespannung des legendären „Rheingold-Expresses“, die sie von der BR 18.5 übernehmen. Bereits seit 1930 befördert das Bw Offenburg ihn mit 01 am Oberrhein bis Basel. In Köln übersteht 01 193 auch den Krieg und gelangt 1948 nach Hamm. Hier befährt sie mit zahlreichen Schwesterloks bis 1959 die Ost-West-Achse Aachen – Hannover und wird dann nach Paderborn überstellt. 1960 erhält sie in Nied einen neuen Hochleistungskessel. Nach nur fünf Jahren wird sie 1964 nach Rheine weitergeleitet, wie von Paderborn aus wendet sie in Kassel und nach Norden in Bremen, Emden und Oldenburg. Für den Einsatz in die Niederlande haben die Rheiner 01 oft einen Tender 2.2T30. Die zunehmende Zuweisung von 01.10 lässt die 01 überflüssig werden, 001 193-2 wird bereits am 21.06.68 ausgemustert. Die Gustav Ahrens GmbH zerlegt sie im September und Oktober 1969 in Essen-Rellinghausen.

EN – The Cologne Reichsbahn directorate did not receive the 01 192 – 198 locomotives for operations along the Rhine until 1936/1937, which was very late indeed. 01 193 was phased out on 21.12.1936 and assigned to the Deutzerfeld railway depot. The area of responsibility for the locomotive included the route of the legendary “Rheingold-Express”, assumed from the BR 18.5. As early as 1930, the Offenburg railway depot operated it with an 01 vehicle along the Upper Rhine to Basel. The 01 193 also survived the war in Cologne and moved to Hamm in 1948. Here, it operated on the East-West axis between Aachen and Hanover with numerous sister locomotives until 1959 and was then transferred to Paderborn. A new high-performance boiler was installed in Nied in 1960. In 1964, it was passed on to Rheine after only five years. As was the case with trains starting in Paderborn, it turned in Kassel and travelled north to Bremen, Emden and Oldenburg. The “Rheiner 01” vehicles were often installed with a 2.2T30 Tender for utilisation in The Netherlands. The increasing allocation of the 01.10 meant that the 01 became expendable, the 001 193-2 was decommissioned as early as 21.06.1968. Gustav Ahrens GmbH dismantled it in Essen-Rellinghausen in September and October 1969.

Rmin 360* Rmin 420 PluX 22 4

PASSENDE WAGEN FINDEN SIE AUF SEITE 36+37
RELATED CARS ARE ON PAGE 36+37

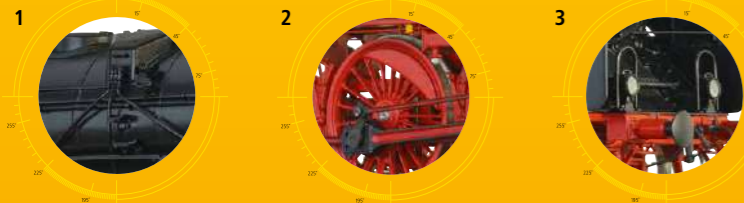

- 1 LEITUNGEN & STELLSTANGEN EINZELN ANGESETZT
EXTRA MOUNTED LINES & PULL ROD
- 2 SPEICHENRÄDER & DURCHBROCHENER BARRENRAHMEN AUS METALL
METAL SPOKED WHEELS & PERFORATED SECTIONAL FRAME
- 3 EPOCHENGERECHTE BELEUCHTUNG MIT LED'S
TRUE-TO-EPOCH LIGHTING WITH LED'S

Dampflokomotive BR 01 der DRG Steam Locomotive BR 01 DRG



Best.-Nr. Order no. **40916** =Analog Basic+ **40917** ~Digital Basic+ **40918*** =Digital EXTRA **40919** ~Digital EXTRA

Betriebs-Nr. | Road no.: 01 032

*40918: werkseitig ausverkauft | sold out

Ausführliche Informationen zur Dampflokomotive BR 01 finden Sie auf der BRAWA Website – wir wünschen Ihnen viel Spaß beim Entdecken zahlreicher Details!

More information about the steam locomotive BR 01 is available on the BRAWA website. We wish you much fun while discovering lots of details!

Dampflokomotive BR 01 der DB Steam Locomotive BR 01 DB



Best.-Nr. Order no. **40904** =Analog Basic+ **40905** ~Digital Basic+ **40906*** =Digital EXTRA **40907** ~Digital EXTRA

Betriebs-Nr. | Road no.: 01 173

*40906: werkseitig ausverkauft | sold out

Dampflokomotive BR 001 der DB Steam Locomotive BR 001 DB



Best.-Nr. Order no. **40908** =Analog Basic+ **40909** ~Digital Basic+ **40910** =Digital EXTRA **40911** ~Digital EXTRA

Betriebs-Nr. | Road no.: 001 088-4

Funktionen Functions	Analog BASIC+ =	Digital BASIC+ ~	Digital EXTRA =	Digital EXTRA ~
Lichtwechsel Light change	+	+	+	+
Feuerflackern Fire flickering			+	+
Führerstandbeleuchtung Driver cabin lighting	⊕ ¹⁾	⊕ ¹⁾	+	+
Triebwerksbeleuchtung Engine lighting			+	+
Rauchgenerator Smoke generator			+	+
Digitalschnittstelle Digital interface	PluX22	PluX22	PluX22	PluX22
Decoder		+	+	+
Sound			+	+

¹⁾ Funktion steht nur im Digitalbetrieb zur Verfügung | Function only available in digital mode



© RVM SAMMLUNG EISENBahnSTIFTUNG

DAMPFLOKOMOTIVE PR. G10 DER P.ST.E.V.

STEAM LOCOMOTIVE PR. G10 P.ST.E.V.

KOHLE-IMITATION HERAUSNEHMBAR
REMOVABLE COAL IMITATION

ANTRIEB IN KESSEL UND RAHMEN
DRIVE IN BOILER AND FRAME

NACHBILDUNG DES BLECHRAHMENS MIT
DURCHBRÜCHEN, SCHRAUBEN UND NIETE
REPLICA OF THE METAL FRAME WITH
OPENINGS, SCREWS AND RIVETS

VORBILD | ORIGINAL

1. Baujahr | Year of construction
1910

Gesamtlänge | Length
18,91 m

Geschwindigkeit | Velocity
60 km/h

Dienstmasse | Service weight
76,6 t

PS | HP
1100



Best.-Nr. Order no.	40800			40801			40802			40803			
Betriebs-Nr. Road no.: Magdeburg 5416													

P.St.E.V.

Hinweis zum Mindestradius der BR 57.10: Die Modelle der Dampflok BR 57.10 sind technisch für den Betrieb ab Mindestradius R 360 mm geeignet. Für optimale Fahreigenschaften empfehlen wir den Einsatz ab R 420 mm, aufgrund der vorbildnahen Umsetzung des Fahrwerks. | The models of BR 57.10 are technically suitable for R 360. For best driving characteristics we recommend the use on R 420, because of the true-to-original realization of the chassis.

SO SCHÖN KLINGT LIEBE ZUM DETAIL
Laden Sie sich jetzt die BRAWA Lok-Sounds mit klangvollen Details herunter – für eine originalgetreue Geräuschkulisse auf Ihrer Modellbahnanlage.

THE SWEET SOUND OF ATTENTION TO DETAIL
Download the richly detailed BRAWA locomotive sounds for true-to-life background noise on your model railway set.

DOWNLOAD

Dampflokomotive pr. G10 der K.P.E.V.

Steam Locomotive pr. G10 K.P.E.V.

Best.-Nr. Order no.	40840	40841	40842	40843	
	=Analog Basic+	=Digital Basic+	=Digital EXTRA	=Digital EXTRA	

Betriebs-Nr. | Road no.: 5490 Königsberg

Dampflokomotive G10 der P.St.E.V.

Steam Locomotive G10 P.St.E.V.

P.St.E.V.

Best.-Nr. Order no.	40860	40861	40862	40863	
	=Analog Basic+	=Digital Basic+	=Digital EXTRA	=Digital EXTRA	

Betriebs-Nr. | Road no.: 5683 Halle

Dampflokomotive 57.10 der DRG

Steam Locomotive 57.10 DRG

Best.-Nr. Order no.	40868	40869	40870	40871	
	=Analog Basic+	=Digital Basic+	=Digital EXTRA	=Digital EXTRA	

Betriebs-Nr. | Road no.: 57 2191

Dampflokomotive 57.10 der DRG

Steam Locomotive 57.10 DRG

Best.-Nr. Order no.	40856*	40857	40858	40859	
	=Analog Basic+	=Digital Basic+	=Digital EXTRA	=Digital EXTRA	

Betriebs-Nr. | Road no.: 57 1673

*40856: werkseitig ausverkauft | sold out

Dampflokomotive 57.10 der DB

Steam Locomotive 57.10 DB

Best.-Nr. Order no.	40844	40845	40846	40847	
	=Analog Basic+	=Digital Basic+	=Digital EXTRA	=Digital EXTRA	

Betriebs-Nr. | Road no.: 57 1390

Dampflokomotive 57.10 der DB

Steam Locomotive 57.10 DB

Best.-Nr. Order no.	40808*	40809	40810*	40811	
	=Analog Basic+	=Digital Basic+	=Digital EXTRA	=Digital EXTRA	

Betriebs-Nr. | Road no.: 57 2070

*40808+40810: werkseitig ausverkauft | sold out

Dampflokomotive 57.10 der DB

Steam Locomotive 57.10 DB

Best.-Nr. Order no.	40864	40865	40866	40867	
	=Analog Basic+	=Digital Basic+	=Digital EXTRA	=Digital EXTRA	

Betriebs-Nr. | Road no.: 57 2146

Dampflokomotive 657 der ÖBB

Steam Locomotive 657 ÖBB

Best.-Nr. Order no.	40820	40821	40822	40823	
	=Analog Basic+	=Digital Basic+	=Digital EXTRA	=Digital EXTRA	

Betriebs-Nr. | Road no.: 657.1915

Dampflokomotive 050 B der SNCF

Steam Locomotive 050 B SNCF

Best.-Nr. Order no.	40824	40825	40826	40827	
	=Analog Basic+	=Digital Basic+	=Digital EXTRA	=Digital EXTRA	

Betriebs-Nr. | Road no.: 050 B 646

Dampflokomotive 61 a der NSB

Steam Locomotive 61 a NSB

Best.-Nr. Order no.	40852	40853	40854	40855	
	=Analog Basic+	=Digital Basic+	=Digital EXTRA	=Digital EXTRA	

Betriebs-Nr. | Road no.: 57 3431

Dampflokomotive 057 der DB

Steam Locomotive 057 DB

Best.-Nr. Order no.	40812	40813	40814	40815	
	=Analog Basic+	=Digital Basic+	=Digital EXTRA	=Digital EXTRA	

Betriebs-Nr. | Road no.: 057 070-5



DAMPFLOKOMOTIVE 98.10

STEAM LOCOMOTIVE 98.10

Dampflokomotive 98.10 der DRG / Grupp. Bayern
Steam Locomotive 98.10 DRG / Grupp. Bayern



Best.-Nr. Order no.	40570* =Analog Basic+	40571* ~Digital Basic+	40572 =Digital EXTRA	40573 ~Digital EXTRA	
------------------------	---------------------------------	----------------------------------	--------------------------------	--------------------------------	--

Betriebs-Nr. | Road no.:

*40570+40571: werkseitig ausverkauft | sold out

Dampflokomotive 98.10 der DRG / Grupp. Bayern
Steam Locomotive 98.10 DRG / Grupp. Bayern



Best.-Nr. Order no.	40578 =Analog Basic+	40579 ~Digital Basic+	40580 =Digital EXTRA	40581 ~Digital EXTRA	
------------------------	--------------------------------	---------------------------------	--------------------------------	--------------------------------	--

Betriebs-Nr. | Road no.: 98 1005

Dampflokomotive 98.10 der DB
Steam Locomotive 98.10 DB



Best.-Nr. Order no.	40574 =Analog Basic+	40575 ~Digital Basic+	40576 =Digital EXTRA	40577 ~Digital EXTRA	
------------------------	--------------------------------	---------------------------------	--------------------------------	--------------------------------	--

Betriebs-Nr. | Road no.: 98 1016



DAMPFLOKOMOTIVE 178

STEAM LOCOMOTIVE 178

Dampflokomotive 178 der BBÖ
Steam Locomotive 178 BBÖ



BB
Österreich

Best.-Nr. Order no.	40796 =Analog Basic+	40798 =Digital EXTRA	
------------------------	--------------------------------	--------------------------------	--

Betriebs-Nr. | Road no.: 178802

Dampflokomotive 422 der CSD
Steam Locomotive 422 CSD



ČSD

Best.-Nr. Order no.	40792 =Analog Basic+	40794* =Digital EXTRA	
------------------------	--------------------------------	---------------------------------	--

Betriebs-Nr. | Road no.: 422.0115

*40794: werkseitig ausverkauft | sold out



ELEKTROLOKOMOTIVE 211 DER DR

ELECTRIC LOCOMOTIVE 211 DR

EINZEL ANGESETZTE
GRIFFSTANGEN UND LEITERN
EXTRA MOUNTED STEPS AND HANDRAILS

ORIGINALGETREUER STROMABNEHMER
TRUE-TO-ORIGINAL PANTOGRAPH

MIT VORBIDLGERECHTEM SOUND
TRUE-TO-ORIGINAL SOUND



Best.-Nr. Order no.	43106 Analog BASIC+	43108 Digital EXTRA		
------------------------	----------------------------------	----------------------------------	--	--

Betriebs-Nr. | Road no.: 211 071-6

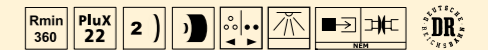

Elektrolokomotive 211 der DR
Electric Locomotive 211 DR



Best.-Nr. Order no.	43110 =Analog Basic+	43112 =Digital EXTRA	
------------------------	--------------------------------	--------------------------------	--

Betriebs-Nr. | Road no.: 211 049-2



Dampflokomotive 178 der BBÖ
Steam Locomotive 178 BBÖ



BB
Österreich

Best.-Nr. Order no.	40796 =Analog Basic+	40798 =Digital EXTRA	
------------------------	--------------------------------	--------------------------------	--

Betriebs-Nr. | Road no.: 178802

Dampflokomotive 422 der CSD
Steam Locomotive 422 CSD



ČSD

Best.-Nr. Order no.	40792 =Analog Basic+	40794* =Digital EXTRA	
------------------------	--------------------------------	---------------------------------	--

Betriebs-Nr. | Road no.: 422.0115

*40794: werkseitig ausverkauft | sold out

Elektrolokomotive E11 der DR
Electric Locomotive E11 DR



Best.-Nr. Order no.	43114 =Analog Basic+	43116 =Digital EXTRA	
------------------------	--------------------------------	--------------------------------	--

Betriebs-Nr. | Road no.: E11 033

Elektrolokomotive 211 der DR
Electric Locomotive 211 DR



Best.-Nr. Order no.	43118 =Analog Basic+	43120 =Digital EXTRA	
------------------------	--------------------------------	--------------------------------	--

Betriebs-Nr. | Road no.: 211 015-3

Elektrolokomotive E42 der DR
Electric Locomotive E42 DR



Best.-Nr. Order no.	43122 =Analog Basic+	43124 =Digital EXTRA	
Betriebs-Nr. Road no.: E42 015			

Elektrolokomotive 242 der DR
Electric Locomotive 242 DR



Best.-Nr. Order no.	43126 =Analog Basic+	43128 =Digital EXTRA	
Betriebs-Nr. Road no.: 242 002-4			

You Tube

Besuchen Sie uns auch auf YouTube und entdecken Sie weitere Funktionen der E44!

Visit our YouTube channel and discover more features about the E44.

WWW.BRAWA.DE

i

Eine detaillierte Funktionsübersicht der E44 finden Sie auf unserer Website anhand der Artikel-Nr.
A detailed overview of functions about the E44 can be found on our website.

Elektrolokomotive E44^w der DRG
Electric Locomotive E44^w DRG



Best.-Nr. Order no.	43420 =Analog Basic+	43421 ~Digital Basic+	43422 =Digital EXTRA	43423 ~Digital EXTRA	
Betriebs-Nr. Road no.: E44 165 ^w					

Elektrolokomotive E44 der DB
Electric Locomotive E44 DB



Best.-Nr. Order no.	43404 =Analog Basic+	43405 ~Digital Basic+	43406 =Digital EXTRA	43407 ~Digital EXTRA	
Betriebs-Nr. Road no.: E44 100					

Elektrolokomotive E44^w der DB
Electric Locomotive E44^w DB



Best.-Nr. Order no.	43408 =Analog Basic+	43409 ~Digital Basic+	43410 =Digital EXTRA	43411 ~Digital EXTRA	
Betriebs-Nr. Road no.: E44 181 ^w					

Elektrolokomotive E44 der DR
Electric Locomotive E44 DR



Best.-Nr. Order no.	43436 =Analog Basic+	43437 ~Digital Basic+	43438 =Digital EXTRA	43439 ~Digital EXTRA	
Betriebs-Nr. Road no.: E44 134					

Elektrolokomotive 144 der DB
Electric Locomotive 144 DB



Best.-Nr. Order no.	43412 =Analog Basic+	43413 ~Digital Basic+	43414 =Digital EXTRA	43415 ~Digital EXTRA	
Betriebs-Nr. Road no.: 144 119-5					

Elektrolokomotive 244 der DR
Electric Locomotive 244 DR



Best.-Nr. Order no.	43416 =Analog Basic+	43417 ~Digital Basic+	43418 =Digital EXTRA	43419 ~Digital EXTRA	
Betriebs-Nr. Road no.: 244 069-1					

Elektrolokomotive 145 der DB
Electric Locomotive 145 DB



Best.-Nr. Order no.	43428 =Analog Basic+	43429 ~Digital Basic+	43430 =Digital EXTRA	43431 ~Digital EXTRA	
Betriebs-Nr. Road no.: 145 168-1					

Elektrolokomotive 144 der DB
Electric Locomotive 144 DB



Best.-Nr. Order no.	43432 =Analog Basic+	43433 ~Digital Basic+	43434 =Digital EXTRA	43435 ~Digital EXTRA	
Betriebs-Nr. Road no.: 144 071-8					

ELEKTROLOKOMOTIVE E44 DER DRG

ELECTRIC LOCOMOTIVE E44 DRG

STROMABNEHMER DER BAUART SBS 10
PANTOGRAPH TYPE SBS 10

FREI STEHENDE DACHLEITUNGEN
FREE STANDING ROOF LINES

VORBILDNAHE DETAILIERUNG DER DREHGESTELLE MIT VIELEN EXTRA ANGESETZTEN TEILEN
TRUE-TO-ORIGINAL DETAILING OF THE BOGIES WITH MANY EXTRA PARTS

Best.-Nr. Order no.	43400 =Analog BASIC+	43401 Digital BASIC+	43402 Digital EXTRA	43403 EXTRA	
Betriebs-Nr. Road no.: E44 007					



ELEKTROLOKOMOTIVE E75 DER DRG

ELECTRIC LOCOMOTIVE E75 DRG



Best.-Nr. Order no.	43200* =Analog Basic+ [Analog Basic+ icon]	43201 =Digital Basic+ [Digital Basic+ icon]	43202* =Digital EXTRA [Digital EXTRA icon]	43203 =Digital EXTRA [Digital EXTRA icon]	[III NEM icon]
------------------------	---	--	---	--	----------------

Betriebs-Nr. | Road no.: E75 06

43200+43202: werkseitig ausverkauft | sold out

Abb. zeigt Handmuster | Picture show layout version

D – Als Weiterentwicklung der E77 bestellte die DRG 1926 weitere Elektrolokomotiven für den Einsatz im süd- und mitteldeutschen Netz. Während die elektrische Ausrüstung fast unverändert blieb, wurde ein neuer einteiliger Fahrzeugrahmen mit der Achsfolge 1'BB1' konstruiert. Durch die Änderungen des Laufwerks setzte man die zulässige Höchstgeschwindigkeit auf 70 km/h fest und erhoffte sich so eine bessere Verwendbarkeit in gemischten Plänen für Reise- und Güterzüge. Von den geplanten 79 Loks gelangten die E75 01-12 nach Süddeutschland, die E75 51-69 wurden nach Leipzig West, Wahren, Bitterfeld und Magdeburg-Buckau geliefert. Die DB besaß nach Ausmusterung der Kriegsschadloks 22 Maschinen, die im süddeutschen Netz im gemischten Dienst eingesetzt wurden. Ab 1968 wurden die 19 noch vorhandenen Triebfahrzeuge in die neue BR 175 umgezeichnet. Die E75 59 blieb erhalten und gehört heute der Deutsche Bahn Stiftung.

EN – In 1926, DRG ordered further electric locomotives as improvements on the E77 for operation in the southern and central German network. While the electrical systems remained virtually unchanged, a new, one-part vehicle frame was designed with the axle sequence 1'BB1'. The locomotive body was similar to the E061 range. Due to the running gear changes, the maximum permissible speed was set at 70 km/h, raising hopes of better utility in mixed passenger and goods train schedules. 79 locomotives were planned. E75 01-12 went to south Germany, while the E75 51-69 went to Leipzig West, Wahren, Bitterfeld and Magdeburg-Buckau. After decommissioning war-damaged locomotives, DB owned 22 engines which were used in mixed service in the south German network. From 1968, the remaining 19 tractive units were redesignated BR 175.



Elektrolokomotive E75 der DRG

Electric Locomotive E75 DRG



Best.-Nr. Order no.	43228 =Analog Basic+ [Analog Basic+ icon]	43229 =Digital Basic+ [Digital Basic+ icon]	43230 =Digital EXTRA [Digital EXTRA icon]	43231 =Digital EXTRA [Digital EXTRA icon]	[II NEM icon]
------------------------	--	--	--	--	---------------

Betriebs-Nr. | Road no.: E75 62

Elektrolokomotive E75 der DRG

Electric Locomotive E75 DRG



Best.-Nr. Order no.	43236 =Analog Basic+ [Analog Basic+ icon]	43238 =Digital EXTRA [Digital EXTRA icon]	43239 =Digital EXTRA [Digital EXTRA icon]	[II NEM icon]
------------------------	--	--	--	---------------

Betriebs-Nr. | Road no.: E75 53

Elektrolokomotive E75 der DB

Electric Locomotive E75 DB



Best.-Nr. Order no.	43216* =Analog Basic+ [Analog Basic+ icon]	43217 =Digital Basic+ [Digital Basic+ icon]	43218 =Digital EXTRA [Digital EXTRA icon]	43219 =Digital EXTRA [Digital EXTRA icon]	[III NEM icon]
------------------------	---	--	--	--	----------------

Betriebs-Nr. | Road no.: E75 66

*43216: werkseitig ausverkauft | sold out

Elektrolokomotive E75 der DB

Electric Locomotive E75 DB



Best.-Nr. Order no.	43232 =Analog Basic+ [Analog Basic+ icon]	43233 =Digital Basic+ [Digital Basic+ icon]	43234 =Digital EXTRA [Digital EXTRA icon]	43235 =Digital EXTRA [Digital EXTRA icon]	[III NEM icon]
------------------------	--	--	--	--	----------------

Betriebs-Nr. | Road no.: E75 55

Elektrolokomotive 175 der DB

Electric Locomotive 175 DB



Best.-Nr. Order no.	43220 =Analog Basic+ [Analog Basic+ icon]	43221 =Digital Basic+ [Digital Basic+ icon]	43222 =Digital EXTRA [Digital EXTRA icon]	43223 =Digital EXTRA [Digital EXTRA icon]	[IV NEM icon]
------------------------	--	--	--	--	---------------

Betriebs-Nr. | Road no.: 175 054-6

Elektrolokomotive 175 der DB Stiftung

Electric Locomotive 175 DB Stiftung



Best.-Nr. Order no.	43224 =Analog Basic+ [Analog Basic+ icon]	43225 =Digital Basic+ [Digital Basic+ icon]	43226 =Digital EXTRA [Digital EXTRA icon]	43227 =Digital EXTRA [Digital EXTRA icon]	[VI NEM icon]
------------------------	--	--	--	--	---------------

Betriebs-Nr. | Road no.: 175 059-5

Elektrolokomotive E75 der DB

Electric Locomotive E75 DB



Best.-Nr. Order no.	43204* =Analog Basic+ [Analog Basic+ icon]	43205 =Digital Basic+ [Digital Basic+ icon]	43206* =Digital EXTRA [Digital EXTRA icon]	43207 =Digital EXTRA [Digital EXTRA icon]	[III NEM icon]
------------------------	---	--	---	--	----------------

Betriebs-Nr. | Road no.: E75 05

*43204+43206: werkseitig ausverkauft | sold out

Elektrolokomotive 175 der DB

Electric Locomotive 175 DB



Best.-Nr. Order no.	43208* =Analog Basic+ [Analog Basic+ icon]	43209 =Digital Basic+ [Digital Basic+ icon]	43210* =Digital EXTRA [Digital EXTRA icon]	43211 =Digital EXTRA [Digital EXTRA icon]	[IV NEM icon]
------------------------	---	--	---	--	---------------

Betriebs-Nr. | Road no.: 175 009-0

*43208+43210: werkseitig ausverkauft | sold out

Elektrolokomotive E75 der DB Stiftung

Electric Locomotive E75 DB Stiftung



Best.-Nr. Order no.	43240 =Analog Basic+ [Analog Basic+ icon]	43242 =Digital EXTRA [Digital EXTRA icon]	43243 =Digital EXTRA [Digital EXTRA icon]	[IV NEM icon]	[V NEM icon]
------------------------	--	--	--	---------------	--------------

Betriebs-Nr. | Road no.: E75 09

[WWW.BRAWA.DE](http://www.brawa.de)

Ausführliche Informationen zu unseren Produkten und Services finden Sie auf der BRAWA Website – wir wünschen Ihnen viel Spaß beim Entdecken zahlreicher Details!

More information about our products and services is available on the BRAWA website. We wish you much fun while discovering lots of details!

ELEKTROLOKOMOTIVE E95 DER DRG

ELECTRIC LOCOMOTIVE E95 DRG

MIT VORBILDGERECHTEM SOUND
TRUE-TO-ORIGINAL SOUND

BEIDE LOKHÄLFTEN MOTORISIERT
BOTH LOCOMOTIVES HALVES MOTORIZED

EPOCHENGERECHTE LED BELEUCHTUNG
TRUE-TO-EPOCH LED LIGHTING



Best.-Nr. Order no.	43158	Analog BASIC+	43159	Digital BASIC+	D&H	43160*	Digital EXTRA	D&H	43161	Digital EXTRA	D&H	II NEU
------------------------	--------------	------------------	--------------	-------------------	-----	---------------	------------------	-----	--------------	------------------	-----	-----------

Betriebs-Nr. | Road no.: E95 01

*43160: werkseitig ausverkauft | sold out

D – Die Deutsche Reichsbahn Gesellschaft wurde 1937 per Gesetz aufgelöst und als Sondervermögen direkt dem Verkehrsminister als Mitglied der Reichsregierung unterstellt. Die neue Rechtsform zeigte sich auch äußerlich an den Lokomotiven, die ein neues Eigentumschild erhielten, eine Verschmelzung von Reichsadler und Parteisymbol. Auch die sechs Lokomotiven der Baureihe E95 erhielten nach und nach dieses neue Symbol. Alle Loks der Baureihe E95 waren zu diesem Zeitpunkt im Bw Hirschberg in Schlesien stationiert.

EN – The Deutsche Reichsbahn Gesellschaft was dissolved in 1937 in accordance with the law and the Deutsche Reichsbahn was directly assigned as special assets to the Transport Minister as member of the German Government. The new legal structure also became evident on the outside of the locomotives, which were given a new identity of ownership, a combination of the imperial eagle and the party symbol. The 6 locomotives in the E95 series were also gradually adorned with this new identity. All locomotives in the E95 series were stationed at this time at the Hirschberg depot in Silesia.



ELEKTROLOKOMOTIVE 186 "ALPINIST" DER BLS

ELECTRIC LOCOMOTIVE 186 "ALPINIST" BLS

VORBILDICHE SILHOUETTE DER DREHGESTELLE
TRUE-TO-EPOCH MODEL SILHOUETTE OF THE BOGIES

LÄNDERSPEZIFISCHE STROMABNEHMER
COUNTRY-SPECIFIC PANTOGRAPHS

LÄNDERSPEZIFISCHE LICHTSIGNALLE INKL. FERNLICHT (NUR BEI DIGITAL EXTRA)
COUNTRY-SPECIFIC LIGHT SIGNALS INCL. FRONT LAMPS (DIGITAL EXTRA ONLY)



Best.-Nr. Order no.	43994	Analog BASIC	43996	Analog BASIC+	43997	Digital BASIC+	D&H	43998	Digital EXTRA	D&H	43999	Digital EXTRA	D&H	VI NEU
------------------------	--------------	-----------------	--------------	------------------	--------------	-------------------	-----	--------------	------------------	-----	--------------	------------------	-----	-----------

Betriebs-Nr. | Road no.: 91 85 4486 504-4



Elektrolokomotive 186 der CROSSRAIL

Electric Locomotive 186 CROSSRAIL



Best.-Nr. Order no.	43800	43802	43803	43804	43805	VI NEU
	=Analog Basic	=Analog Basic+	=Digital Basic+	=Digital EXTRA	=Digital EXTRA	

Betriebs-Nr. | Road no.: 91 80 6186 150-9

Elektrolokomotive Re der Green Cargo

Electric Locomotive Re Green Cargo



Best.-Nr. Order no.	43964	43966	43967	43968	43969	VI NEU
	=Analog Basic	=Analog Basic+	=Digital Basic+	=Digital EXTRA	=Digital EXTRA	

Betriebs-Nr. | Road no.: 91 74 000 1428-3

Elektrolokomotive 119 der CargoNet

Electric Locomotive 119 CargoNet



Best.-Nr. Order no.	43988	43990	43991	43992	VI NEU
	=Analog Basic+	=Digital Basic+	=Digital EXTRA	=Digital EXTRA	

Betriebs-Nr. | Road no.: 91 76 0119 002-3

Elektrolokomotive E95 der DRG

Electric Locomotive E95 DRG



Best.-Nr. Order no.	43162	43163	43164	43165*	II NEU
	=Analog Basic+	=Digital Basic+	=Digital EXTRA	=Digital EXTRA	

Betriebs-Nr. | Road no.: E95 06

*43165: werkseitig ausverkauft | sold out

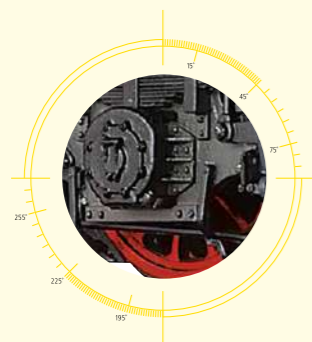

VORBILD | ORIGINAL

- 1. Baujahr | Year of construction
1927
- Gesamtlänge | Length
20,9 m
- Geschwindigkeit | Velocity
70 km/h
- Dienstmasse | Service weight
138,5 t
- PS | HP
2778

WWW.BRAWA.DE



Eine detaillierte Funktionsübersicht der BR186 finden Sie auf unserer Website.
A detailed overview of functions about the BR186 can be found on our website.

DIESELLOKOMOTIVE V60 DER DB

DIESEL LOCOMOTIVE V60 DB



FAHRWERK BELEUCHTET
ILLUMINATED UNDERCARRIAGE

GEÄTZTER KÜHLERSCHUTZ UND
AUFSTIEGSTRITTE
ETCHED RADIATOR GRILLE AND STEPS

ROT-WEISSER LICHTWECHSEL
RED/WHITE LIGHT CHANGE



VORBILD | ORIGINAL

- 1. Baujahr | Year of construction
1955
- Gesamtlänge | Length
10,45 m
- Geschwindigkeit | Velocity
60 km/h
- Dienstmasse | Weight
49,5 t
- PS | HP
650

Best.-Nr. Order no.	42400	Analog BASIC+	42402	Digital EXTRA	Digitale Kuppung	Energie Speicher	D&H	42403	Digital EXTRA	Digitale Kuppung	Energie Speicher	D&H	III NEU
------------------------	--------------	------------------	-------	------------------	---------------------	---------------------	-----	-------	------------------	---------------------	---------------------	-----	------------

Betriebs-Nr. | Road no.: V60 583



Abb. zeigt Handmuster | Picture show layout version

DIESELLOKOMOTIVE V90 DER DB

DIESEL LOCOMOTIVE V90 DB

VOLLSTÄNDIGE NACHBILDUNG DES
BREMSGESTÄNGES
REPRODUCTION OF THE BRAKE LINKAGE

BAUREIHENSPEZIFISCHE
VORBAUTEN MIT DURCHBROCHENEN
KÜHLERJALOUSIEN
SERIES SPECIFIC STEMS WITH OPEN
WORK RADIATOR SHUTTER

DIGITALKUPPLUNG (NUR BEI
DIGITAL EXTRA)
DIGITAL COUPLING (DIGITAL EXTRA
ONLY)



Best.-Nr. Order no.	41544	Analog BASIC	41546	Analog BASIC+	Energie Speicher	D&H	41547	Digital BASIC+	Energie Speicher	D&H	41548	Digital EXTRA	Digitale Kuppung	Energie Speicher	D&H	III NEU
------------------------	--------------	-----------------	-------	------------------	---------------------	-----	-------	-------------------	---------------------	-----	-------	------------------	---------------------	---------------------	-----	------------

Betriebs-Nr. | Road no.: V90 039

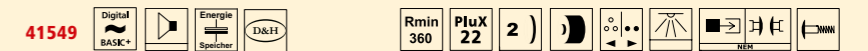

DieSELLOKOMOTIVE 261 der DB

DieSEL Locomotive 261 DB



Best.-Nr. Order no.	42404	=Analog Basic+	42406	=Digital EXTRA	42407	=Digital EXTRA	IV NEU
------------------------	--------------	----------------	-------	----------------	-------	----------------	-----------

Betriebs-Nr. | Road no.: 261 158-0

DieSELLOKOMOTIVE 362 der DB AG

DieSEL Locomotive 362 DB AG



Best.-Nr. Order no.	42408	=Analog Basic+	42410	=Digital EXTRA	42411	=Digital EXTRA	V NEU
------------------------	--------------	----------------	-------	----------------	-------	----------------	----------

Betriebs-Nr. | Road no.: 362 768-4

DieSELLOKOMOTIVE 290 der DB

DieSEL Locomotive 290 DB



Best.-Nr. Order no.	41550*	=Analog Basic	41551	=Analog Basic+	41552	=Digital Basic+	41553	=Digital EXTRA	41554	=Digital EXTRA	IV NEU
------------------------	---------------	---------------	-------	----------------	-------	-----------------	-------	----------------	-------	----------------	-----------

Betriebs-Nr. | Road no.: 290 132-0

*41550: werkseitig ausverkauft | sold out

DieSELLOKOMOTIVE 291 der DB

DieSEL Locomotive 291 DB



Best.-Nr. Order no.	41556	=Analog Basic	41558	=Analog Basic+	41559	=Digital Basic+	41560	=Digital EXTRA	41561	=Digital EXTRA	IV NEU
------------------------	--------------	---------------	-------	----------------	-------	-----------------	-------	----------------	-------	----------------	-----------

Betriebs-Nr. | Road no.: 291 020-6

DieSELLOKOMOTIVE 362 der DB AG

DieSEL Locomotive 362 DB AG



Best.-Nr. Order no.	42412	=Analog Basic+	42414	=Digital EXTRA	42415	=Digital EXTRA	VI NEU
------------------------	--------------	----------------	-------	----------------	-------	----------------	-----------

Betriebs-Nr. | Road no.: 362 390-7



Ausführliche Informationen zur DieSELlok V60 finden Sie auf der BRAWA Website – wir wünschen Ihnen viel Spaß beim Entdecken zahlreicher Details!

More information about the diesel locomotive V60 is available on the BRAWA website. We wish you much fun while discovering lots of details!

DieSELLOKOMOTIVE 294 der DB

DieSEL Locomotive 294 DB



Best.-Nr. Order no.	41568	=Analog Basic	41570	=Analog Basic+	41571	=Digital Basic+	41572	=Digital EXTRA	41573	=Digital EXTRA	VI NEU
------------------------	--------------	---------------	-------	----------------	-------	-----------------	-------	----------------	-------	----------------	-----------

Betriebs-Nr. | Road no.: 294 154-0

DieSELLOKOMOTIVE 295 "Metrans Hamburg" der Metrans

DieSEL Locomotive 295 "Metrans Hamburg" Metrans



Best.-Nr. Order no.	41532	=Analog Basic	41534	=Analog Basic+	41535	=Digital Basic+	41536	=Digital EXTRA	41537	=Digital EXTRA	VI NEU
------------------------	--------------	---------------	-------	----------------	-------	-----------------	-------	----------------	-------	----------------	-----------

Betriebs-Nr. | Road no.: 295 092-1

II METRANS



DIESELLOKOMOTIVE 212 DER DB

DIESEL LOCOMOTIVE 212 DB



Best.-Nr. Order no.	42860 =Analog Basic+	42861 =Digital Basic+	42862 =Digital EXTRA	42863 =Digital EXTRA
Betriebs-Nr. Road no.: 212 074-9				

Diesellokomotive 213 "Bahnbau Gruppe" der DB AG
Diesel Locomotive 213 "Bahnbau Gruppe" DB AG

DB

Best.-Nr. Order no.	42876 =Analog Basic+	42877 =Digital Basic+	42878 =Digital EXTRA	42879 =Digital EXTRA	VI
Betriebs-Nr. Road no.: 213 332-0					

Diesellokomotive 213 "Rennsteigbahn" der RBG
Diesel Locomotive 213 "Rennsteigbahn" RBG

VI

Best.-Nr. Order no.	42884 =Analog Basic+	42885 =Digital Basic+	42886 =Digital EXTRA	42887 =Digital EXTRA	VI
Betriebs-Nr. Road no.: 213 334-6					

UNSER VORBILD IST DAS ORIGINAL
Spannende Informationen zu den Vorbildern unserer Modelle finden Sie unter www.brawa.de

OUR MODELS ARE BASED ON THE ORIGINALS
Find out exciting information about the originals of our models at www.brawa.de

Diesellokomotive 261 der DB AG
Diesel Locomotive 261 DB AG

DB

Best.-Nr. Order no.	41800 =Analog Basic+	41802 =Digital EXTRA	41803 =Digital EXTRA	VI
Betriebs-Nr. Road no.: 261 050-9				

Diesellokomotive V100.20 der DB
Diesel Locomotive V100.20 DB

DB

Best.-Nr. Order no.	42868 =Analog Basic+	42869 =Digital Basic+	42870* =Digital EXTRA	42871 =Digital EXTRA	IV
Betriebs-Nr. Road no.: V 100 2007					

Diesellokomotive 213 der DB
Diesel Locomotive 213 DB

DB

Best.-Nr. Order no.	42864 =Analog Basic+	42865 =Digital Basic+	42866 =Digital EXTRA	42867 =Digital EXTRA	IV
Betriebs-Nr. Road no.: 213 340-3					

Diesellokomotive 265 der DB AG
Diesel Locomotive 265 DB AG

DB

Best.-Nr. Order no.	42732 =Analog Basic+	42734 =Digital EXTRA	42735 =Digital EXTRA	VI
Betriebs-Nr. Road no.: 265 022-4				

Diesellokomotive 261 der DB AG
Diesel Locomotive 261 DB AG

DB

Best.-Nr. Order no.	42792 Ausverk./Sold out	42794 =Digital Basic+	42795 =Digital EXTRA	42796 =Digital EXTRA	VI
Betriebs-Nr. Road no.: 261 036-8					

Diesellokomotive 847 der Sersa
Diesel Locomotive 847 Sersa

sersa

Best.-Nr. Order no.	42872 =Analog Basic+	42873 =Digital Basic+	42874 =Digital EXTRA	42875 =Digital EXTRA	V
Betriebs-Nr. Road no.: Am 847 951-1					

Diesellokomotive BR 211 der Salzburger Lokalbahn
Diesel Locomotive BR 211 Salzburger Lokalbahn

SLB

Best.-Nr. Order no.	42880 =Analog Basic+	42881 =Digital Basic+	42882 =Digital EXTRA	42883 =Digital EXTRA	VI
Betriebs-Nr. Road no.: V 86					

Diesellokomotive 132 der DR
Diesel Locomotive 132 DR

DR

Best.-Nr. Order no.	41434 =Analog Basic+	41436 =Digital EXTRA	VI
Betriebs-Nr. Road no.: 132 673-5			

Diesellokomotive 232 der DB AG
Diesel Locomotive 232 DB AG

DB

Best.-Nr. Order no.	41446 =Analog Basic+	41448 =Digital EXTRA	41449 =Digital EXTRA	V
Betriebs-Nr. Road no.: 232 297-2				



VERBRENNUNGSTRIEBWAGEN VT 60.5 UND STEUERWAGEN VS 145 DER DB

DIESEL RAILCAR VT 60.5 AND CONTROL CAR VS 145 DB

KURZKUPPLUNGSKINEMATIK
SHORT COUPLING KINEMATICS

ANTRIEB AUF ZWEI AXSEN
DRIVE TO TWO AXLES

VORBILDGETREUE WELLRADSCHLEIBEN
TRUE TO ORIGINAL CORRUGATED WHEEL DISKS



Best.-Nr. Order no.	44704	Analog BASIC+	44705	Digital BASIC+	D&H	44706	Digital EXTRA	Digital Kupplung	Energie Speicher	D&H	44707	Digital EXTRA	Digital Kupplung	Energie Speicher	D&H	III NEH
------------------------	--------------	------------------	--------------	-------------------	-----	--------------	------------------	---------------------	---------------------	-----	--------------	------------------	---------------------	---------------------	-----	------------

Betriebs-Nr. | Road no.: VT60 505; VS145 232

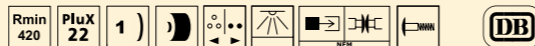

44707: werkseitig ausverkauft | sold out

Abb. zeigt Illustration | Picture show illustration

Verbrennungstriebwagen VT 137 und Beiwagen VS145 der DRG, Doppelheit

Diesel Railcar VT 137 and Trailer VS145 DRG, Double unit



Best.-Nr. Order no.	44700	44701	44702	44703	II NEH
	=Analog Basic+	~Digital Basic+	=Digital EXTRA	~Digital EXTRA	

Betriebs-Nr. | Road no.: VT 137 355; VS 145 246

Verbrennungstriebwagen VT 137 der DR

Diesel Railcar VT 137 DR

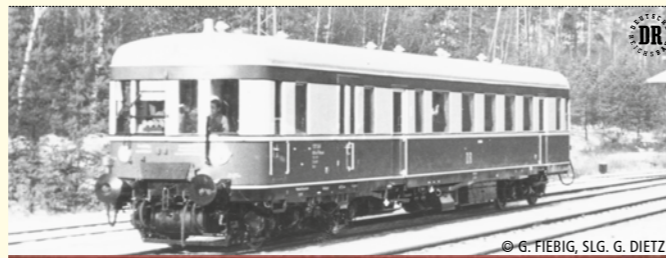

Best.-Nr. Order no.	44712*	44713	44714	44715	III NEH
	=Analog Basic+	~Digital Basic+	=Digital EXTRA	~Digital EXTRA	

Betriebs-Nr. | Road no.: VT 137 366

*44712: werkseitig ausverkauft | sold out

Verbrennungstriebwagen 660 und Beiwagen BR 945 der DB

Diesel Railcar 660 and Trailer BR 945 DB



Best.-Nr. Order no.	44708	44709*	44710	44711	IV NEH
	=Analog Basic+	~Digital Basic+	=Digital EXTRA	~Digital EXTRA	

Betriebs-Nr. | Road no.: 660 516-6; 945 832-4

*44709: werkseitig ausverkauft | sold out



[WWW.BRAWA.DE](http://www.brawa.de)

Ausführliche Informationen zu unseren Produkten und Services finden Sie auf der BRAWA Website – wir wünschen Ihnen viel Spaß beim Entdecken zahlreicher Details!

More information about our products and services is available on the BRAWA website. We wish you much fun while discovering lots of details!

Verbrennungstriebwagen VT137 der DR

Diesel Railcar VT137 DR



Best.-Nr. Order no.	44378	44379	44380	44381	III NEH
	=Analog Basic+	~Digital Basic+	=Digital EXTRA	~Digital EXTRA	

Betriebs-Nr. | Road no.: VT137 007

Verbrennungstriebwagen Cmdo 9 der NSB

Diesel Railcar Cmdo 9 NSB



Best.-Nr. Order no.	44800	44802	44803	III NEH
	=Analog Basic+	=Digital EXTRA	~Digital EXTRA	

Betriebs-Nr. | Road no.: 18292

Verbrennungstriebwagen VT 137 und Beiwagen VT 147 der DR

Diesel Railcar VT 137 and Trailer VT 147 DR



Best.-Nr. Order no.	44394	44396	44397	III NEH
	=Analog Basic+	=Digital EXTRA	~Digital EXTRA	

Betriebs-Nr. | Road no.: VT 137 013 HI; VB 147 022 HI

Verbrennungstriebwagen VT 62.9 und Beiwagen VB 147 der DB

Diesel Railcar VT 62.9 and Trailer VB 147 DB



Best.-Nr. Order no.	44386	44388	44389	III NEH
	=Analog Basic+	=Digital EXTRA	~Digital EXTRA	

Betriebs-Nr. | Road no.: VT 62 905 Han; VB 147 015 Han

Verbrennungstriebwagen VT 137 und Beiwagen VB147 der DRG

Diesel Railcar VT 137 and Trailer VB 147 DRG



Best.-Nr. Order no.	44382	44384	44385	II NEH
	=Analog Basic+	=Digital EXTRA	~Digital EXTRA	

Betriebs-Nr. | Road no.: 876 Wuppertal; 956 Wuppertal

Verbrennungstriebwagen VT 62.9 der DB

Diesel Railcar VT 62.9 DB



Best.-Nr. Order no.	44374	44375	44376	44377	III NEH
	=Analog Basic+	~Digital Basic+	=Digital EXTRA	~Digital EXTRA	

Betriebs-Nr. | Road no.: VT 62 902

Elektrotriebwagen ET 65 der SVG

Electric Railcar ET 65 SVG

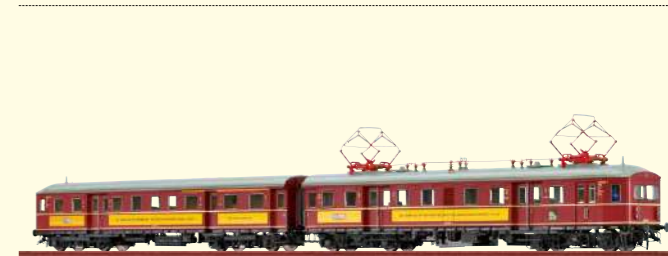

Best.-Nr. Order no.	44088	44089	44090*	44091*	V NEH
	=Analog Basic+	~Digital Basic+	=Digital EXTRA	~Digital EXTRA	

Betriebs-Nr. | Road no.: 465 005-7; 865 611-8

*44090+44091: werkseitig ausverkauft | sold out

TWINDEXX VARIO® IC2-DOPPELSTOCK-WAGENSET DER DB AG, 3ER-SET

TWINDEXX VARIO® IC2-DOUBLE-DECK COACHES DB AG, SET OF 3



Best.-Nr. Order no.	44504*	Analog BASIC+	44507	Digital EXTRA	44514	Digital EXTRA	VI NEMO
------------------------	---------------	------------------	--------------	------------------	--------------	------------------	------------

Betriebs-Nr. | Road no.: 50 80 86-81 873-1 / 50 80 26-81 402-2 / 50 80 26-81 469-1

*44504: werkseitig ausverkauft | sold out

D – Intercity 2 (IC 2) ist der neue Name für die seit dem Fahrplanwechsel zum 13.12.2015 eingesetzten TWINDEXX-Vario® Züge bei DB Fernverkehr. Der TWINDEXX-Vario® ist eine Weiterentwicklung der bewährten Doppelstockplattform aus Görlitz. Pro Zug stehen 468 Sitzplätze, davon 70 in der 1. Klasse sowie 10 Fahrradstellplätze zur Verfügung. Die zulässige Höchstgeschwindigkeit der Züge beträgt 160 km/h. Schon im Jahr 2010 erhielt Bombardier Transportation einen ersten Auftrag über 27 fünfteilige Doppelstockwagenzüge in Kombination mit Lokomotiven der BR 146.5 aus einem vorab geschlossen Rahmenvertrag über insgesamt 800 Doppelstockwagen mit der DB AG. Mittlerweile wurde aus diesem Rahmenvertrag 69 Zügeinheiten mit insgesamt 328 einzelnen Wagen abgerufen.

EN – Intercity 2 (IC 2) is the new name for the DB Fernverkehr AG TWINDEXX Vario® trains introduced following the timetable change on 13.12.2015. The TWINDEXX-Vario® is a further development of the tried-and-trusted double-deck platform from Görlitz. Each train has 468 seats, 70 of which are in 1st class, as well as 10 bicycle parking spaces. The trains have a maximum permissible speed of 160 km/h. It was right back in 2010 that Bombardier Transportation received its first order for 27 five-part double-deck trains in combination with BR 146.5 locomotives. These were ordered under a framework contract for a total of 800 double-deck coaches that had already been concluded with DB AG in advance. Since then, 69 train units comprising a total of 328 individual coaches have been called off under this framework contract.



TWINDEXX VARIO® IC2-DOPPELSTOCK-WAGENSET DER DB REGIO, 3ER-SET

TWINDEXX VARIO® DOUBLE-DECK TRAIN DB REGIO, 3-UNIT



Best.-Nr. Order no.	44500	Analog BASIC+	44502	Digital EXTRA	D&H	44503	Digital EXTRA	D&H	VI NEMO
------------------------	--------------	------------------	--------------	------------------	-----	--------------	------------------	-----	------------

Betriebs-Nr. | Road no.: 91 80 0445 062-6; 50 80 26-81 539-1; 91 80 0445 056-8

D – Doppelstockzüge bilden bereits seit vielen Jahren erfolgreich das Rückgrat im Regionalverkehr. Insbesondere auf Strecken mit geringer Bahnsteiglänge und hohem Fahrgastaufkommen sind Doppelstockzüge die ideale Lösung. Das bewährte Einzelwagenkonzept der TWINDEXX Vario Doppelstockflotte wird nun durch einen elektrischen Triebwagen ergänzt. Bombardier Transportation wird 16 Bombardier TWINDEXX Vario Triebzüge mit Regionalzug-Ausstattung an die Deutsche Bahn AG liefern. Die neuen vierteiligen Triebzüge der Generation Do 2010 setzen sich aus jeweils zwei Triebwagen und zwei Mittelwagen zusammen. Mit dem neu entwickelten angetriebenen TWINDEXX Vario Triebwagen können die Züge nun auch als reine Doppelstock-Triebzüge eingesetzt werden.

EN – For many years now, double-decker trains have successfully formed the backbone of regional traffic. Double-decker trains are the ideal solution, especially on routes with low platform lengths and a high volume of passengers. The tried-and-tested single-wagon concept of the TWINDEXX Vario double-decker fleet is now being supplemented with an electrical railcar. Bombardier Transportation will supply 16 Bombardier TWINDEXX Vario railcars with regional train equipment to Deutsche Bahn AG. The new four-part railcars from the "Do 2010" generation consist of 2 railcars and 2 middle wagons respectively. With the newly-developed driven TWINDEXX Vario railcar, it is now possible to utilise the trains as pure double-decker multiple unit trains.



TWINDEXX Vario® IC2-Mittelwagen 1. Klasse der DB AG
TWINDEXX Vario® IC2 middle Wagon 1st class DB AG

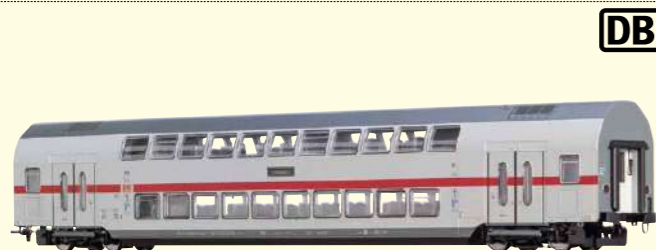

Best.-Nr. Order no.	44505*	=Analog Basic+	44508	=Digital EXTRA	44515*	=Digital EXTRA	VI NEMO
------------------------	---------------	----------------	--------------	----------------	---------------	----------------	------------

Betriebs-Nr. | Road no.: 50 80 16-81 171-5

*44505+44515: werkseitig ausverkauft | sold out

TWINDEXX Vario® IC2-Mittelwagen 2. Klasse der DB AG
TWINDEXX Vario® IC2 middle Wagon 2nd class DB AG



Best.-Nr. Order no.	44506*	=Analog Basic+	44509	=Digital EXTRA	44516*	=Digital EXTRA	VI NEMO
------------------------	---------------	----------------	--------------	----------------	---------------	----------------	------------

Betriebs-Nr. | Road no.: 50 80 26-81 468-3

*44506+44516: werkseitig ausverkauft | sold out

You Tube

*
Besuchen Sie uns auf Youtube und entdecken Sie die digitalen Funktionen des BRAWA Twindexx Vario® IC2!

Visit our Youtube Channel and discover the digital functions of the BRAWA Twindexx Vario® IC2!

TWINDEXX Vario® Mittelwagen 1./2. Klasse der DB Regio
TWINDEXX Vario® IC2 middle Wagon 1./2nd class DB AG



Best.-Nr. Order no.	44510	=Analog Basic+	44512	=Digital EXTRA	44513	=Digital EXTRA	VI NEMO
------------------------	--------------	----------------	--------------	----------------	--------------	----------------	------------

Betriebs-Nr. | Road no.: 50 80 36-81 163-8

Abb. zeigt N-Modell | Pictures show N-Model

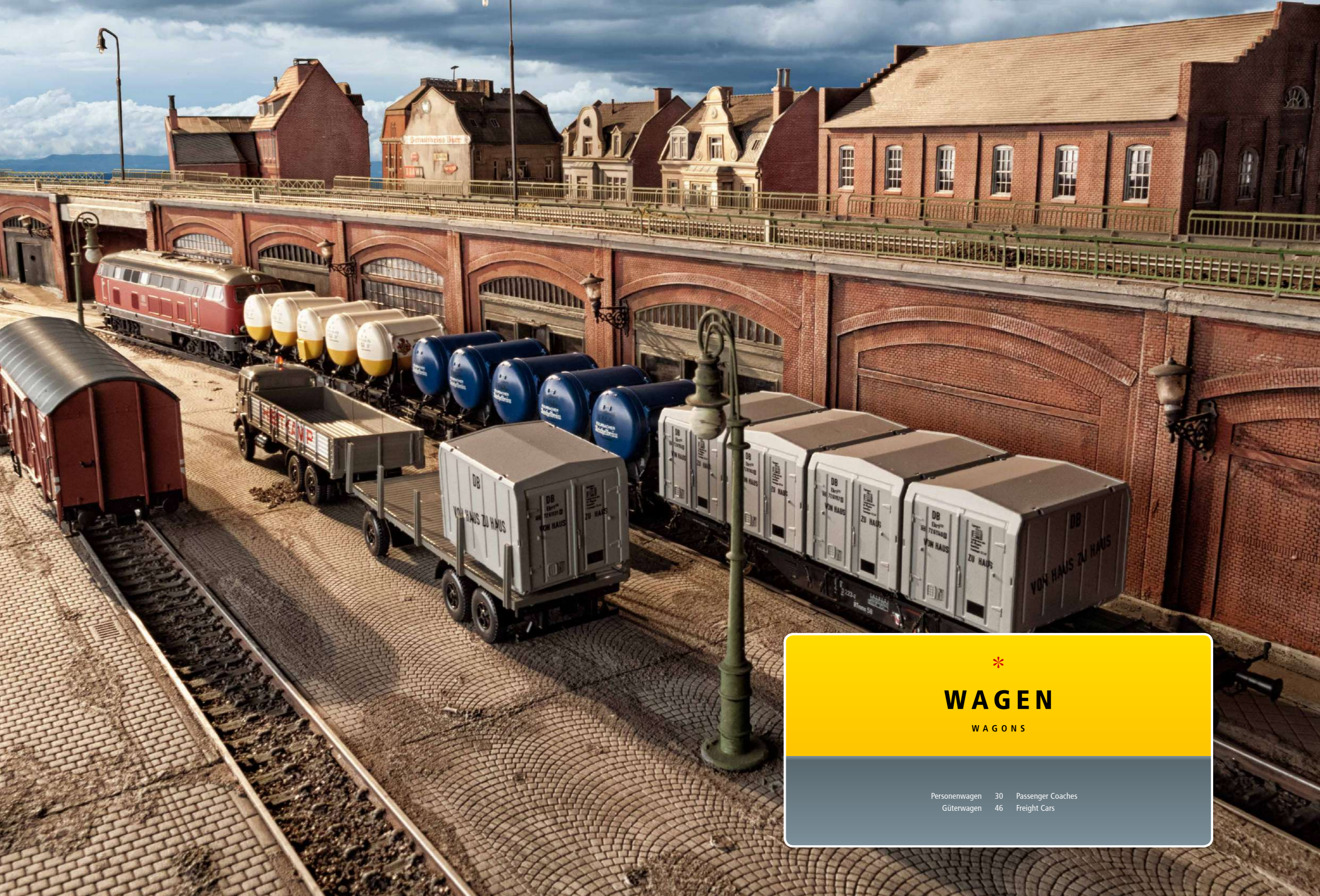

WAGEN

WAGONS

Personenwagen	30	Passenger Coaches
Güterwagen	46	Freight Cars



EILZUGWAGEN BC4I DER DRG

FAST TRAIN COACHES BC4I DRG



Best.-Nr.
Order no. **46150**



Betriebs-Nr. | Road no.: 33 581 Nür



- 1 NACHBILDUNG DER DACHNIETEN
REPLICA OF THE RIVETS ON THE ROOF
- 2 PASSGENAU EINGESETZTE FENSTER
IN-PLANE ASSEMBLED WINDOWS
- 3 EXAKT NACHGEBILDETE GÖRLITZ III LEICHT DREHGESTELLE
PRECISE REPLICA OF THE GÖRLITZ III BOGIES WITH QUADRUPLE SPRING SYSTEM



Eilzugwagen C4i der DRG
Fast Train Coaches C4i DRG



Best.-Nr.
Order no. **46151**



Betriebs-Nr. | Road no.: 73 441 Nür

Eilzugwagen C4i der DRG
Fast Train Coaches C4i DRG



Best.-Nr.
Order no. **46152**



Betriebs-Nr. | Road no.: 73 428 Nür

Eilzugwagen BC4i der DRG
Fast Train Coaches BC4i DRG



Best.-Nr.
Order no. **46180**



Betriebs-Nr. | Road no.: 33 698 Nür

Eilzugwagen C4i der DRG
Fast Train Coaches C4i DRG



Best.-Nr.
Order no. **46181**



Betriebs-Nr. | Road no.: 73428 Reg

Eilzugwagen AB4yswe der DB
Fast Train Coaches AB4yswe DB



Best.-Nr.
Order no. **46153**



Betriebs-Nr. | Road no.: 33 602 Ffm

Eilzugwagen B4ywe der DB
Fast Train Coaches B4ywe DB



Best.-Nr.
Order no. **46154**



Betriebs-Nr. | Road no.: 73 582 Ffm

Eilzugwagen B4ywe der DB
Fast Train Coaches B4ywe DB



Best.-Nr.
Order no. **46155**



Betriebs-Nr. | Road no.: 74 002 Ffm

Eilzugwagen WL4ü-36/50 der DSG
Fast Train Coaches WL4ü-36/50 DSG



Best.-Nr.
Order no. **46169**



Betriebs-Nr. | Road no.: 19 110

Eilzugwagen WG4ü-36/50 der DB
Fast Train Coaches WG4ü-36/50 DB



Best.-Nr.
Order no. **46170**



Betriebs-Nr. | Road no.: 74 454 Köl

Eilzugwagen APw4yse-36/54 der DB
Fast Train Coaches APw4yse-36/54 DB



Best.-Nr.
Order no. **46172**



Betriebs-Nr. | Road no.: 25 295 Hmb

Eilzugwagen B4ye-36/50 der DB
Fast Train Coaches B4ye-36/50 DB



Best.-Nr.
Order no. **46174**



Betriebs-Nr. | Road no.: 73 864 Ffm

Eilzugwagen B4ye-36/50 der DB
Fast Train Coaches B4ye-36/50 DB



Best.-Nr.
Order no. **46175**



Betriebs-Nr. | Road no.: 74 249 Ffm

Eilzugwagen BR4ye-36/51 der DB
Fast Train Coaches BR4ye-36/51 DB



Best.-Nr.
Order no. **46176**



Betriebs-Nr. | Road no.: 73 844 Ffm

Eilzugwagen WG4ü-36/50 der DB
Fast Train Coaches WG4ü-36/50 DB



Best.-Nr.
Order no. **46187**



Betriebs-Nr. | Road no.: 10 815 Han

Eilzugwagen APw4yse der DB
Fast Train Coaches APw4yse DB



Best.-Nr.
Order no. **46189**



Betriebs-Nr. | Road no.: 25 294 Hmb

Eilzugwagen ABghe der DR
Fast Train Coaches ABghe DR



Best.-Nr.
Order no. **46182**



Betriebs-Nr. | Road no.: 244-136

Eilzugwagen Bghe der DR
Fast Train Coaches Bghe DR



Best.-Nr.
Order no. **46183**



Betriebs-Nr. | Road no.: 245-310

Eilzugwagen C4üPWL der DSG
Fast Train Coaches C4üPWL DSG



Best.-Nr.
Order no. **46168**

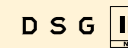

Betriebs-Nr. | Road no.: 19 104 Han



Eilzugwagen WR4yke-36-49 der DSG

Fast Train Coaches WR4yke-36-49 DSG



Best.-Nr. Order no. **46191** **DSG** III
 Betriebs-Nr. | Road no.: 555

Eilzugwagen AB4ipü der ÖBB

Fast Train Coaches AB4ipü ÖBB



Best.-Nr. Order no. **46165** **ÖBB** III
 Betriebs-Nr. | Road no.: 22 543

Eilzugwagen Bye 667 der DB

Fast Train Coaches Bye 667 DB



Best.-Nr. Order no. **46157** **DB** IV
 Betriebs-Nr. | Road no.: 50 80 28-11 477-7 Hmb

Eilzugwagen Bye 667 der DB

Fast Train Coaches Bye 667 DB



Best.-Nr. Order no. **46158** **DB** IV
 Betriebs-Nr. | Road no.: 50 80 28-11 617-8 Hmb

Eilzugwagen WGYe 831.1 der DB

Fast Train Coaches WGYe 831.1 DB



Best.-Nr. Order no. **46171** **DB** IV
 Betriebs-Nr. | Road no.: 50 80 89-53 705-6

Eilzugwagen WL4ü-36/50 der DSG

Fast Train Coaches WL4ü-36/50 DSG

SCHLAFWAGEN VORBILDGETREU MIT NACHBILDUNG DER BETTEN
 SLEEPING CAR TRUE TO THE ORIGINAL WITH REPLICA OF THE BEDS

VARIANTENBEZOGENE ÜBERGÄNGE (OFFEN, FALTENBALG ODER GUMMIWULST)
 VARIANT RELATED TRANSITIONS (OPEN, BELLOWS OR RUBBER BULGE)



Best.-Nr. Order no. **46186** **DSG** III
 Betriebs-Nr. | Road no.: 19 105

Eilzugwagen ABühe der DR

Fast Train Coaches ABühe DR



Best.-Nr. Order no. **46159** **DR** IV
 Betriebs-Nr. | Road no.: 57 50 38-14 667-7 Hal

Eilzugwagen Bühe der DR

Fast Train Coaches Bühe DR



Best.-Nr. Order no. **46160** **DR** IV
 Betriebs-Nr. | Road no.: 57 50 27-14 582-1 Hal

Eilzugwagen Bühe der DR

Fast Train Coaches Bühe DR



Best.-Nr. Order no. **46161** **DR** IV
 Betriebs-Nr. | Road no.: 57 50 27-14 589-6 Hal

Eilzugwagen Bye 667 der DB

Fast Train Coaches Bye 667 DB



Best.-Nr. Order no. **46177** **DB** IV
 Betriebs-Nr. | Road no.: 50 80 28-11 344-9

Eilzugwagen Bye 667 der DB

Fast Train Coaches Bye 667 DB



Best.-Nr. Order no. **46178** **DB** IV
 Betriebs-Nr. | Road no.: 50 80 28-11 524-6

Eilzugwagen BRYe 693 der DB

Fast Train Coaches BRYe 693 DB



Best.-Nr. Order no. **46179** **DB** IV
 Betriebs-Nr. | Road no.: 50 80 85-11 026-2

Eilzugwagen B4ipü der ÖBB

Fast Train Coaches B4ipü ÖBB



Best.-Nr. Order no. **46166** **ÖBB** III
 Betriebs-Nr. | Road no.: 32 122

Eilzugwagen B4ye der ÖBB

Fast Train Coaches B4ye ÖBB



Best.-Nr. Order no. **46167** **ÖBB** III
 Betriebs-Nr. | Road no.: 32 161

Eilzugwagen A5B5tiz der SNCF

Fast Train Coaches A5B5tiz SNCF



Best.-Nr. Order no. **46162** **SNCF** III
 Betriebs-Nr. | Road no.: 11820

Eilzugwagen B9ti der SNCF

Fast Train Coaches B9ti SNCF



Best.-Nr. Order no. **46163** **SNCF** III
 Betriebs-Nr. | Road no.: 14917

Eilzugwagen B9ti der SNCF

Fast Train Coaches B9ti SNCF



Best.-Nr. Order no. **46164** **SNCF** III
 Betriebs-Nr. | Road no.: 14914

Eilzugwagen AByse 630 der DB

Fast Train Coaches AByse 630 DB



Best.-Nr. Order no. **46156** **DB** IV
 Betriebs-Nr. | Road no.: 50 80 37-11 549-3 Hmb

Eilzugwagen ADyse 641 der DB

Fast Train Coaches ADyse 641 DB

NACHBILDUNG DES GEPÄCKABTEILS
 REPLICA OF THE LUGGAGE COMPARTMENT

VORBILDGETREU VERSCHLOSSENE EINSTIEGSTÜREN
 TRUE-TO-ORIGINAL CLOSED ENTRY DOORS



Best.-Nr. Order no. **46173** **DB** IV
 Betriebs-Nr. | Road no.: 50 80 81-11 003-5

GEPÄCKWAGEN MPW4IE DER DB

LUGGAGE CAR MPW4IE DB

PERSONENWAGEN ABYEE DER MAV

PASSENGER COACH ABYEE MAV



Best.-Nr. 46251
Order no.

Betriebs-Nr. | Road no.: 113 710 Ffm

Best.-Nr. 46034
Order no.

Betriebs-Nr. | Road no.: 50 55 31-55 019-0

Gepäckwagen MPW4ie der DB, 2er-Set
Luggage Car MPW4ie DB, set of 2

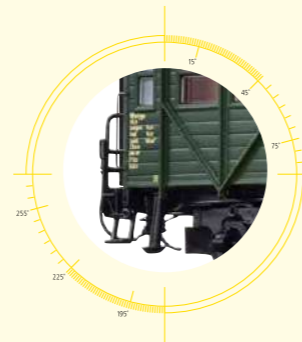

Best.-Nr. 46252
Order no.

Betriebs-Nr. | Road no.: 113 967 Hmb

D – Durch die zunehmende Erneuerung des Wagenparks sowie die Einführung neuer Triebwagen sind bei der DB etliche „Halberstädter“ entbehrlich geworden. Dadurch ergab sich für die Ungarische Staatsbahn die Möglichkeit insgesamt ca. 300 Aby und Byz Wagen zur Modernisierung ihres eigenen Fahrzeugparks von der DB zu erwerben. Die Wagen präsentieren sich mittlerweile fast alle in einer an das DB Farbschema angeglichene grau-blauen Lackierung. Eingesetzt werden die Wagen durch die MÁV Tochtergesellschaft MÁV-START.

EN – Quite a number of "Halberstädter" coaches were made dispensable within the Deutsche Bundesbahn (DB) due to the advancing renewal of the rolling stock and the introduction of new railcars. This gave the Hungarian State Railway (MÁV) the opportunity of acquiring a total of around 300 Aby and Byz coaches from the DB in order to modernise their own rolling stock. Meanwhile, almost all of these coaches appear in a grey-blue paint coat adapted to the DB colour scheme. The coaches are being employed by MÁV's subsidiary MÁV-START.



Betriebs-Nr. abweichend | Deviating road no.

Gepäckwagen MPW4i der DB
Luggage Car MPW4i DB



Best.-Nr. 46257
Order no.

Betriebs-Nr. | Road no.: 113 880 Kar

Gepäckwagen MD4yge der DB
Luggage Car MD4yge DB



Best.-Nr. 46258
Order no.

Betriebs-Nr. | Road no.: 113 993 Stg

Gepäckwagen MDyg 986 der DB
Luggage Car MDyg 986 DB



Best.-Nr. 46253
Order no.

Betriebs-Nr. | Road no.: 50 80 92-11 491-9



Personenwagen Byee der MAV
Passenger Coach Byee MAV



Best.-Nr. 46035
Order no.

Betriebs-Nr. | Road no.: 50 55 21-55 041-6

Gepäckwagen MDyg 986 der DB
Luggage Car MDyg 986 DB



Best.-Nr. 46254
Order no.

Betriebs-Nr. | Road no.: 50 80 92-11 301-0

Gepäckwagen MDyg 986 der DB
Luggage Car MDyg 986 DB



Best.-Nr. 46256
Order no.

Betriebs-Nr. | Road no.: 50 80 92-40 906-1

Gepäckwagen MDyg 986 der DB
Luggage Car MDyg 986 DB



Best.-Nr. 46259
Order no.

Betriebs-Nr. | Road no.: 50 80 92-11 823-3 Ffm

Personenwagen ABYz der GYSEV
Passenger Coach ABYz GYSEV



Best.-Nr. 46036
Order no.

Betriebs-Nr. | Road no.: 51 43 31-30 004-6

Personenwagen BDyz der GYSEV
Passenger Coach BDyz GYSEV



Best.-Nr. 46037
Order no.

Betriebs-Nr. | Road no.: 51 43 84-33 003-1

RHEINGOLD

RHEINGOLD

SCHNELLZUGWAGEN 5ER-SET DER DRG

RHEINGOLD EXPRESS TRAIN CAR SET OF 5 DRG

Schnellzugwagen SA4üK-28 der DRG
Express Train Coach SA4ü-28 DRG



Best.-Nr. Order no. **45916** = **45917** **45918** **45919**

Betriebs-Nr. | Road no.: 10 502 Köln

Alle Abb. zeigen Handmuster | All pictures show layout versions

Schnellzugwagen SA4üK-28 der DRG
Express Train Coach SA4üK-28 DRG



Betriebs-Nr. | Road no.: 10 501 Köln

Salonwagen 1. Klasse, mit Küche | Salon coach 1st class with kitchen

Schnellzugwagen SB4ü-28 der DRG
Express Train Coach SB4ü-28 DRG



Betriebs-Nr. | Road no.: 10 702 Köln

Salonwagen 1. Klasse | Salon coach 1st class

Schnellzugwagen SB4üK-29 der DRG
Express Train Coach SB4üK-29 DRG



Betriebs-Nr. | Road no.: 10 707 Köln

Salonwagen 2. Klasse, mit Küche | Salon coach 2nd class with kitchen

Gepäckwagen SPw4ü-28 der DRG
Express Train Coach SPw4ü-28 DRG



Betriebs-Nr. | Road no.: 105 001 Köln

DIE WAGEN DES RHEINGOLD-EXPRESS IN DEN NACHKRIEGSJAHREN

THE CARRIAGES OF THE RHEINGOLD EXPRESS IN THE POST-WAR YEARS

Schnellzugwagen B4üe-28/52 "F-Zugwagen" der DB
Express Train Car B4üe-28/52 "F-Zugwagen" DB



Best.-Nr. Order no. **46410**

Betriebs-Nr. | Road no.: 10 702 Au

Schnellzugwagen B4üe-28/52 "F-Zugwagen" der DB
Express Train Car B4üe-28/52 "F-Zugwagen" DB



Best.-Nr. Order no. **46411**

Betriebs-Nr. | Road no.: 10 706 Han

Schnellzugwagen B4üe-28/52 "F-Zugwagen" der DB
Express Train Car B4üe-28/52 "F-Zugwagen" DB



Best.-Nr. Order no. **46412**

Betriebs-Nr. | Road no.: 10 708 Esn

Schnellzugwagen Pw4ü-28 der DB
Express Train Car Pw4ü-28 DB



Best.-Nr. Order no. **46413**

Betriebs-Nr. | Road no.: 105 001 Köl

Schnellzugwagen WR4ü-28/51 der DSG
Express Train Car WR4ü-28/51 DSG



Best.-Nr. Order no. **46414**

Betriebs-Nr. | Road no.: 1232

Schnellzugwagen WGükle-29/50 der DB
Express Train Car WGükle-29/50 DB



Best.-Nr. Order no. **46415**

Betriebs-Nr. | Road no.: 10 803 Mü

Schnellzugwagen Aüe 305 der DB
Express Train Car Aüe 305 DB



Best.-Nr. Order no. **46416**

Betriebs-Nr. | Road no.: 51 80 18-43 060-4

Schnellzugwagen Aüe 305 der DB
Express Train Car Aüe 305 DB



Best.-Nr. Order no. **46417**

Betriebs-Nr. | Road no.: 51 80 18-43 061-2

Schnellzugwagen Düe 949 der DB
Express Train Car Düe 949 DB



Best.-Nr. Order no. **46418**

Betriebs-Nr. | Road no.: 51 80 92-43 311-0

Schnellzugwagen WRü(e) 151 der DB
Express Train Car WRü(e) 151 DB



Best.-Nr. Order no. **46419**

Betriebs-Nr. | Road no.: 51 80 88-46 232-1

Schnellzugwagen WGük 822 der DB
Express Train Car WGük 822 DB



Best.-Nr. Order no. **46420**

Betriebs-Nr. | Road no.: 51 80 89-43 522-7

WWW.BRAWA.DE



Alle Informationen wie z.B. LüP oder der Tauschradsatz für Wechselstrom finden Sie auf unserer Website.

All information such as LüP or the exchange wheel set for AC can be found on our website.

FÜR EINEN ORIGINALGETREUEN FAHRBETRIEB AUF IHRER ANLAGE EMPFEHLEN WIR IHNEN DIE DAMPFLOK BR 01 AUF SEITE 6+7
FOR A TRUE TO ORIGINAL TRAIN OPERATION WE RECOMMEND THE STEAM LOCOMOTIVE BR 01 ON PAGE 6+7



SILBERLINGE – DIE PERSONENWAGEN DER DB

SILBERLINGE – PASSENGER COACHES DB

Steuerwagen BPw4nf-59 der DB
Controll Car BPw4nf-59 DB



Best.-Nr. 46503 Analog BASK+ 2212 46504 Digital BASK+ 2212 46523 Analog BASK+ 2212 III NEU

Betriebs-Nr. | Road no.: 96 360

PluX 22, DB, III NEU

Hasenkasten inkl. LED-Stirnbeleuchtung | "Hasenkasten" incl. LED front lights

Steuerwagen BDnf 738 der DB
Controll Car BDnf DB



Best.-Nr. 46508 Analog BASK+ 2212 46509 Digital BASK+ 2212 46527 Analog BASK+ 2212 IV NEU

Betriebs-Nr. | Road no.: 50 80 82-34 101-9

PluX 22, DB, IV NEU

Karlsruher Kopf inkl. LED-Stirnbeleuchtung und Zugzielbeleuchtung | "Karlsruhe version incl. LED front lights and train destination lights

Nahverkehrswagen AB4n-59 der DB
Passenger Coach AB4n-59 DB



Best.-Nr. 46500 Analog BASK+ 2212 46520 Analog BASK+ 2212 III NEU

Betriebs-Nr. | Road no.: 31 053

1./2. Klasse Wagen | Coach 1st/2nd class

Nahverkehrswagen B4nb-59 der DB
Passenger Coach B4nb-59 DB



Best.-Nr. 46501 Analog BASK+ 2212 46521 Analog BASK+ 2212 III NEU

Betriebs-Nr. | Road no.: 41 059

2. Klasse Wagen | Coach 2nd class

Nahverkehrswagen ABn 703 der DB
Passenger Coach ABn 703 DB



Best.-Nr. 46505 Analog BASK+ 2212 46524 Analog BASK+ 2212 IV NEU

Betriebs-Nr. | Road no.: 50 80 31-11 224-4

1./2. Klasse Wagen | Coach 1st/2nd class

Nahverkehrswagen Bn 719 der DB
Passenger Coach Bn 719 DB



Best.-Nr. 46506 Analog BASK+ 2212 46525 Analog BASK+ 2212 IV NEU

Betriebs-Nr. | Road no.: 50 80 22-11 067-2

2. Klasse Wagen | Coach 2nd class

Nahverkehrswagen B4nb-59 der DB
Passenger Coach B4nb-59 DB



Best.-Nr. 46502 Analog BASK+ 2212 46522 Analog BASK+ 2212 III NEU

Betriebs-Nr. | Road no.: 41 245

2. Klasse Wagen | Coach 2nd class

UNSER VORBILD IST DAS ORIGINAL
Spannende Informationen zu den Vorbildern unserer Modelle finden Sie unter www.brawa.de

OUR MODELS ARE BASED ON THE ORIGINALS
Find out exciting information about the originals of our models at www.brawa.de

Nahverkehrswagen Bn 719 der DB
Passenger Coach Bn 719 DB



Best.-Nr. 46507 Analog BASK+ 2212 46526 Analog BASK+ 2212 IV NEU

Betriebs-Nr. | Road no.: 50 80 22-11 090-4

2. Klasse Wagen | Coach 2nd class

MINTLINGE – DIE PERSONENWAGEN DER DB

MINTLINGE – PASSENGER COACHES DB

Steuerwagen BDnrdzf 463 der DB AB
 Controll Car BDnrdzf 463 DB AG



Best.-Nr. 46513 Analog 46514 Digital 46531 Analog
 Order no. BASK+ 2212 BASK+ 2212 BASK+ 2212

Betriebs-Nr. | Road no.: 50 80 82-34 090-4
 PluX 22, DB logo, and other technical icons.

Karlsruher Kopf inkl. LED-Stirnbeleuchtung und Zugzielbeleuchtung | Karlsruhe version incl. LED front lights and train destination lights

ROTLINGE – DIE PERSONENWAGEN DER DB

ROTLINGE – PASSENGER COACHES DB

Steuerwagen Bnrdzf 483.1 der DB AG
 Controll Car Bnrdzf 483.1 DB AG



Best.-Nr. 46518 Analog 46519 Digital 46535 Analog
 Order no. BASK+ 2212 BASK+ 2212 BASK+ 2212

Betriebs-Nr. | Road no.: 50 80 80-35 191-1
 PluX 22, DB logo, and other technical icons.

Wittenberger Kopf inkl. LED-Stirnbeleuchtung und Zugzielbeleuchtung | Wittenberg version incl. LED front lights and train destination lights

Nahverkehrswagen ABnrz 403 der DB AG
 Passenger Coach ABnrz 403 DB AG



Best.-Nr. 46510 46528
 Order no. 2212 = 2212

Betriebs-Nr. | Road no.: 50 80 31-34 345-4

1./2. Klasse Wagen | Coach 1st/2nd class

*
SCHIENENKLASSIKER DES NAHVERKEHRS
CLASSICS OF LOCAL TRANSPORT

- Variantengerechte Bauartunterschiede
- Unterschiedlich ausgeführte Wagenböden mit versch. Heizungsbauarten
- Genaue Nachbildung der Minden-Deutz leicht Drehgestelle MD 42/MD 43
- Mehrteilige Inneneinrichtungen der Epoche entsprechend

- True-to-original construction differences
- Different roof designs with accurate reproduction of welding seams
- Accurate reproduction of Minden-Deutz MD 42 or MD 43 light bogie
- Multi-part interior fittings corresponding to the period

WWW.BRAWA.DE

Ausführliche Informationen zu unseren Produkten und Services finden Sie auf der BRAWA Website – wir wünschen Ihnen viel Spaß beim Entdecken zahlreicher Details!

More information about our products and services is available on the BRAWA website. We wish you much fun while discovering lots of details!

Nahverkehrswagen ABnrz 418.4 der DB AG
 Passenger Coach ABnrz 418.4 DB AG



Best.-Nr. 46515 46532
 Order no. 2212 = 2212

Betriebs-Nr. | Road no.: 50 80 31-34 266-2

1./2. Klasse Wagen | Coach 1st/2nd class

Nahverkehrswagen Bnr 436 der DB AG
 Passenger Coach Bnr 436 DB AG



Best.-Nr. 46511 46529
 Order no. 2212 = 2212

Betriebs-Nr. | Road no.: 50 80 22-33 600-4

2. Klasse Wagen | Coach 2nd class

Nahverkehrswagen Bnr 436 der DB AG
 Passenger Coach Bnr 436 DB AG



Best.-Nr. 46512 46530
 Order no. 2212 = 2212

Betriebs-Nr. | Road no.: 50 80 22-34 314-1

2. Klasse Wagen | Coach 2nd class

Nahverkehrswagen Bnrz 446.0 der DB AG
 Passenger Coach Bnrz 446.0 DB AG



Best.-Nr. 46516 46533
 Order no. 2212 = 2212

Betriebs-Nr. | Road no.: 50 80 22-34 119-4

2. Klasse Wagen | Coach 2nd class

Nahverkehrswagen Bnrz 446.0 der DB AG
 Passenger Coach Bnrz 446.0 DB AG



Best.-Nr. 46517 46534
 Order no. 2212 = 2212

Betriebs-Nr. | Road no.: 50 80 22-34 801-7

2. Klasse Wagen | Coach 2nd class



PERSONENWAGEN CID 21 DER DRG

PASSENGER COACH CID 21 DRG

EXTRA ANGESETZTE WENDLERLÜFTER
EXTRA MOUNTED WENDLER FAN

ORIGINALGETREUE INNENEINRICHTUNG
TRUE-TO-ORIGINAL INTERIOR FITTINGS

DREIDIMENSIONAL AUSGEBILDETES DIX-GITTER
THREE-DIMENSIONAL DIX-GRID



Best.-Nr.
Order no. **45763**



Betriebs-Nr. | Road no.: 81 401 Nürnberg

D – Zwischen 1921 und 1923 entstanden 2236 Wagen der Bauart Di 21, mit leicht abweichender Inneneinrichtung noch 397 Wagen der Bauart Di 21a. Kein anderer deutscher Personenwagen sollte je wieder eine solche Stückzahl erreichen. Die Wagen boten 66 Sitzplätze in der 4. Klasse. Bei einer Länge über Puffer von 13 920 mm hatten sie einen Radstand von 8500 mm, was einen ruhigen Wagenlauf ergab. Nach Abschaffung der 4. Klasse im Jahr 1928 wurden die Wagen in die 3. Klasse hochgestuft und in Cid 21 umbenannt.

EN – From 1921 to 1923, a total of 2,236 Di 21 type coaches were built. 397 Di 21a-type coaches with slightly different interior fittings were also built. No other German passenger coach was ever built in such a large number. The coaches could seat 66 passengers in fourth class. They had a length over buffers of 13 920 mm and an 8,500 mm wheelbase, which ensured that they ran very quietly. When fourth class was abolished in 1928, the coaches were upgraded to third class and given the designation Cid 21.



Personenwagen Bi 21 der DB
Passenger Coach Bi 21 DB



Best.-Nr.
Order no. **45764**



Betriebs-Nr. | Road no.: 81 257 Ksl

Personenwagen Bitr der DR
Passenger Coach Bitr DR



Best.-Nr.
Order no. **45765**



Betriebs-Nr. | Road no.: 340-345

Personenwagen BPosti der DR
Passenger Coach BPosti DR



Best.-Nr.
Order no. **45766**



Betriebs-Nr. | Road no.: 311-608

Personenwagen Civ-33 der DB
Passenger Coach Civ-33 DB



Best.-Nr.
Order no. **45540**



Betriebs-Nr. | Road no.: 85 778 Ksl

Personenwagen Ci-33 der DB
Passenger Coach Ci-33 DB



Best.-Nr.
Order no. **45541**



Betriebs-Nr. | Road no.: 85 871 Ksl

Personenwagen VB 140 der DB
Passenger Coach VB 140 DB



Best.-Nr.
Order no. **45544**



Betriebs-Nr. | Road no.: 140 397 Kar

Personenwagen VB 140 der DB
Passenger Coach VB 140 DB



Best.-Nr.
Order no. **45543**



Betriebs-Nr. | Road no.: 140 402 Kar

Personenwagen Cu der kkStB
Passenger Coach Cu kkStB



Best.-Nr.
Order no. **45643**



Betriebs-Nr. | Road no.: 9104

Personenwagen Cu der ÖBB
Passenger Coach Cu ÖBB



Best.-Nr.
Order no. **45645**



Betriebs-Nr. | Road no.: 47 162

Personenwagen Cu der ÖBB
Passenger Coach Cu ÖBB



Best.-Nr.
Order no. **45646**



Betriebs-Nr. | Road no.: 47 104

Personenwagen Cu der BBÖ
Passenger Coach Cu BBÖ



Best.-Nr.
Order no. **45649**



Betriebs-Nr. | Road no.: 47 042

Personenwagen Cu der BBÖ
Passenger Coach Cu BBÖ

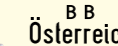

Best.-Nr.
Order no. **45650**



Betriebs-Nr. | Road no.: 47 101

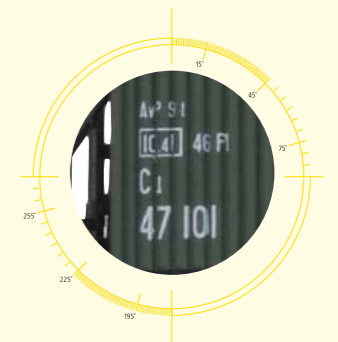

Aktuelles von BRAWA automatisch erfahren
Einfach unter www.brawa.de den kostenlosen BRAWA Newsletter abonnieren.

Automatically receive news from BRAWA

Simply subscribe to the free BRAWA newsletter at www.brawa.de and you'll always know what's currently happening.





ABTEIL- UND UMBAUWAGEN TÄGLICHE REISEMÖGLICHKEIT FÜR MILLIONEN

COMPARTMENT AND CONVERTED COACH
DAILY TRAVEL OPPORTUNITY FOR MILLIONS

Personenwagen B3tr der DB
Passenger Coach B3tr DB



Best.-Nr.
Order no. **45489**



Betriebs-Nr. | Road no.: 053 456 Han

Personenwagen C3 der DRG
Passenger Coach C3 DRG



Best.-Nr.
Order no. **45486**



Betriebs-Nr. | Road no.: 57 252 Altona

Personenwagen B3 der DB
Passenger Coach B3 DB



Best.-Nr.
Order no. **45488**



Betriebs-Nr. | Road no.: 057 780 Han

Personenwagen C3tr der DRG
Passenger Coach C3tr DRG



Best.-Nr.
Order no. **45487**



Betriebs-Nr. | Road no.: 59 899 Altona

Personenwagen B3yge der DB, 2er-Set
Passenger Coach B3yge DB, set of 2



Best.-Nr.
Order no. **46306**



Betriebs-Nr. | Road no.: 87 026 Kar; 87 027 Kar

Personenwagen AB3yge & B3YGE der DB, 2er-Set
Passenger Coach AB3yge & B3YGE DB, set of 2



Best.-Nr.
Order no. **46307**



Betriebs-Nr. | Road no.: 37 545 Kar; 87 112 Kar

Personenwagen B3yge & BPW3YGE der DB, 2er-Set
Passenger Coach B3yge & BPW3YGE DB, set of 2



Best.-Nr.
Order no. **46308**



Betriebs-Nr. | Road no.: 87 111 Kar; 99 318 Kar

Personenwagen B3yge der DB, 2er-Set
Passenger Coach B3yge DB, set of 2



Best.-Nr.
Order no. **46309**



Betriebs-Nr. | Road no.: 50 80 23-11 102-6 Reg; 50 80 23-11 122-4 Reg

Personenwagen Bghw der DR
Passenger Coach Bghw DR



Best.-Nr.
Order no. **45374**



Betriebs-Nr. | Road no.: 50 50 28-13 288-2

Personenwagen Bghw der DR
Passenger Coach Bghw DR



Best.-Nr.
Order no. **45375**



Betriebs-Nr. | Road no.: 50 50 28-13 676-8



GEDECKTER GÜTERWAGEN GMHHS 30 DER DB

COVERED FREIGHT CAR GMHHS 30 DB

DURCHBROCHENE
WAGENKASTENSTÜTZE
PERFORATED COACH
BODY SUPPORTS

EINZEL ANGESETZTE
GRIFSTANGEN UND TRITTE
EXTRA MOUNTED HANDRAILS
AND STEPS

EINZEL ANGESETZTE
ACHSLAGERDECKEL
INDIVIDUALLY MOUNTED
AXLE BOX COVER



Best.-Nr.
Order no. **47958**

Betriebs-Nr. | Road no.: 224 482

Gedekter Güterwagen Grs der DRG
Covered Freight Car Grs DRG



Best.-Nr.
Order no. **47948**

Betriebs-Nr. | Road no.: 28 300

Gedekter Güterwagen Gms 30 "Libella" der DB
Covered Freight Car Gms 30 "Libella" DB



Best.-Nr.
Order no. **47936**

Betriebs-Nr. | Road no.: 225 466

Gedekter Güterwagen Gms 30 "EUROP" der DB
Covered Freight Car Gms 30 "EUROP" DB



Best.-Nr.
Order no. **47949**

Betriebs-Nr. | Road no.: 221 847

Gedekter Güterwagen Gms 30 "Anker Brot" der ÖBB
Covered Freight Car Gms 30 "Anker Brot" ÖBB



Best.-Nr.
Order no. **47940**

Betriebs-Nr. | Road no.: 140 333

Gedekter Güterwagen Gms 30 "PEZ" der ÖBB
Covered Freight Car Gms 30 "PEZ" ÖBB



Best.-Nr.
Order no. **47941**

Betriebs-Nr. | Road no.: 140 477

Gedekter Güterwagen Gms der ÖBB
Covered Freight Car Gms ÖBB



Best.-Nr.
Order no. **47952**

Betriebs-Nr. | Road no.: 140 061

Gedekter Güterwagen Gms der ÖBB
Covered Freight Car Gms ÖBB



Best.-Nr.
Order no. **47962**

Betriebs-Nr. | Road no.: 141 709

Gedekter Güterwagen Gms 30 "EUROP" der SAAR
Covered Freight Car Gms 30 "EUROP" SAAR



Best.-Nr.
Order no. **47973**

Betriebs-Nr. | Road no.: 17 002

Gedekter Güterwagen Kr "EUROP" der SNCF
Covered Freight Car Kr "EUROP" SNCF



Best.-Nr.
Order no. **47953**

Betriebs-Nr. | Road no.: 7440903

Gedekter Güterwagen Gklm 200 der DB
Covered Freight Car Gklm 200 DB



Best.-Nr.
Order no. **47951**

Betriebs-Nr. | Road no.: 21 80 145 2 994-3

Gedekter Güterwagen Gklm 200 der DB
Covered Freight Car Gklm 200 DB



Best.-Nr.
Order no. **47959**

Betriebs-Nr. | Road no.: 01 80 145 3 885-6

Gedekter Güterwagen Hkms der DR
Covered Freight Car Hkms DR



Best.-Nr.
Order no. **47961**

Betriebs-Nr. | Road no.: 27 50 222 7038-1

Gedekter Güterwagen Gms 30 "EUROP" der DB
Covered Freight Car Gms 30 "EUROP" DB



Best.-Nr.
Order no. **47950**

Betriebs-Nr. | Road no.: 228 096

Gedekter Güterwagen Grs "ALAK" der Brit-US-Zone
Covered Freight Car Grs "ALAK" Brit-US-Zone



Best.-Nr.
Order no. **47956**

Betriebs-Nr. | Road no.: 5088

Gedekter Güterwagen Mrhhs der DR
Covered Freight Car Mrhhs DR



Best.-Nr.
Order no. **47960**

Betriebs-Nr. | Road no.: 07-56-71

AKTUELLES VON BRAWA AUTOMATISCH ERFAHREN
AUTOMATICALLY RECEIVE NEWS FROM BRAWA



Einfach unter www.brawa.de den kostenlosen BRAWA Newsletter abonnieren
und Sie wissen immer, was gerade läuft.

Simply subscribe to the free BRAWA newsletter at www.brawa.de and you'll always know what's
currently happening.

WWW.BRAWA.DE/NEWSLETTER

Offener Güterwagen Saarbrücken der K.P.E.V.
Open Freight Car Saarbrücken K.P.E.V.



Best.-Nr.
Order no. **48802**

Betriebs-Nr. | Road no.: 57 811



Offener Güterwagen Otw "Eschweiler Bergwerksverein Grube Anna"
Open Freight Car Otw "Eschweiler Bergwerksverein Grube Anna"



Best.-Nr.
Order no. **48803**

Betriebs-Nr. | Road no.: 307



Schienenwagen S51a Köln der DRG
Rail Car S51a Köln DRG



Best.-Nr.
Order no. **47218**

Betriebs-Nr. | Road no.: 15 582



Schienenwagen RRlyw der CFL
Rail Car RRlyw CFL



Best.-Nr.
Order no. **47231**

Betriebs-Nr. | Road no.: 42423



Schienenwagen Rrywv der SNCF
Rail Car Rrywv SNCF



Best.-Nr.
Order no. **47232**

Betriebs-Nr. | Road no.: 198285



Rungenwagen Rmms der FS
Stake Car Rmms FS



Best.-Nr.
Order no. **47114**

Betriebs-Nr. | Road no.: 31 83 395 9 085-9



Rungenwagen Remms 665 der DB
Stake Car Remms 665 DB



Best.-Nr.
Order no. **47116**

Betriebs-Nr. | Road no.: 31 80 394 8 280-3



Rungenwagen Rmms der SNCB
Stake Car Rmms SNCB



Best.-Nr.
Order no. **47118**

Betriebs-Nr. | Road no.: 31 88 397 1064-3



Schienenwagen R672 der DB
Rail Car R672 DB



Best.-Nr.
Order no. **47219**

Betriebs-Nr. | Road no.: 30 80 380 0 416-3



WWW.BRAWA.DE



Alle Informationen wie z.B. LüP oder der Tauschradsatz für Wechselstrom finden Sie auf unserer Website.

All information such as LüP or the exchange wheel set for AC can be found on our website.

Arbeitswagen Xr 35 der Brit-US-Zone
Maintenance Car Xr 35 Brit-US-Zone

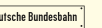

Best.-Nr.
Order no. **49351**

Betriebs-Nr. | Road no.: 462 671



Rungenwagen Rmms der TSS
Stake Car Rmms TSS



Best.-Nr.
Order no. **47115**

Betriebs-Nr. | Road no.: 33 54 3959 066-2

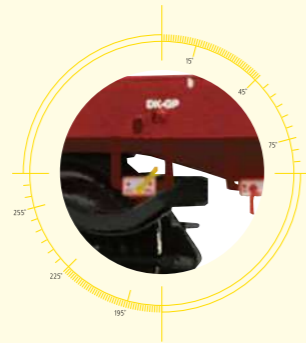

Rungenwagen Samm-u 453 der DB AG
Stake Car Samm-u 453 DB AG



Best.-Nr.
Order no. **47501**

Betriebs-Nr. | Road no.: 31-80-482 0 026-1



Arbeitswagen Xr 35 der DB
Maintenance Car Xr 35 DB



Best.-Nr.
Order no. **49355**

Betriebs-Nr. | Road no.: 20 80 327 1 031-0



Arbeitswagen Kklmmo 493 der DB
Maintenance Car Kklmmo 493 DB



Best.-Nr.
Order no. **49352**

Betriebs-Nr. | Road no.: 20 80 327 1 039-3



Arbeitswagen Kklmmo 493 der DB
Maintenance Car Kklmmo 493 DB



Best.-Nr.
Order no. **49357**

Betriebs-Nr. | Road no.: 20 80 327 1 035-1





BEHÄLTERTRAGWAGEN BTMMS 58 "VON HAUS ZU HAUS" DER DB

CONTAINER CAR BTMMS 58 "VON HAUS ZU HAUS" DB

AUFBAU MIT 5 FORMNEUEN
STAUBGUTBEHÄLTERN (EFKR 401)
WITH 5 NEW POWDER GOODS
CONTAINERS (EFKR 401)

ORIGINALGETREU WIEDERGEWEBENER,
DREIDIMENSIONALER RAHMENAUFBAU
ORIGINALLY REPRODUCED, THREE-
DIMENSIONAL FRAME BODY

DREIPUNKTLAGERUNG FÜR
EINE SICHERE FAHRT
BOGIE WITH THREE-POINT SUPPORT



Best.-Nr.
Order no. **49131**



Betriebs-Nr. | Road no.: 020 333

Abb. zeigt Handmuster | Picture show layout version

D – Für nassempfindliche Schüttgüter wie Getreide, Mehl, Zucker oder Kalk entwickelte man bei der Bundesbahn den Mittelcontainer Typ Efrk 401. Dieser freizügig einsetzbare Container (auf allen Bauarten der Behältertragwagen), konnte auf dem Scheitel d.h. von oben zur Beladung geöffnet werden. Zum Entleeren musste man den Efrk 401 jedoch zu einer Seite kippen und anschließend die Auslaufklappe öffnen. Dieses Entladeprinzip war auch von den offenen Güterwagen mit Stirnklappe bekannt. Die Eignung für den Lebensmitteltransport der Container fand sehr schnell Anklang bei der Industrie, was unter anderem namenhafte Nudelhersteller dazu bewog, die in festen Wagenumläufen verplanten Container mit ihrer Hauswerbung zu versehen. Über den Zeitraum von rund 13 Jahren entstanden etwa 6700 Stück Efrk 401, die sich zusammen mit den BT-Wagen bis Anfang der 1990er Jahre im Einsatz befanden.

EN – For moisture-sensitive bulk freight such as grain, flour, sugar or lime, the Federal Railway developed the Efrk 401 type medium container. This container, which could be used freely with all types of container wagon, could be opened at the top from above for loading. However, for emptying, the Efrk 401 still had to be tilted to one side and the discharge outlet opened. This unloading concept was already well known from the open goods wagons with front flaps. The containers' suitability for transporting food meant that it gained rapid popularity within the industry, which led well-known pasta producers, among others, to place their company's advertising on the containers which were used in fixed circulation. Over a period of approximately 13 years, in the region of 6700 Efrk 401 units were produced and used in conjunction with the BT wagon up to the early 1990s.



Behältertragwagen BTmms 58
"Birkel" der DB
Container Car BTmms 58 "Birkel" DB



Best.-Nr.
Order no. **49132**



Betriebs-Nr. | Road no.: 020 124

Efrk 401 Container

Behältertragwagen Ls der CSD
Container Car Ls CSD



ČSD



Best.-Nr.
Order no. **49134**



Betriebs-Nr. | Road no.: 21 54 042 0014-3

Efrk 401 Container

Behältertragwagen Lbs 589 "Knorr"
der DB
Container Car Lbs 589 "Knorr" DB



Best.-Nr.
Order no. **49135**



Betriebs-Nr. | Road no.: 21 80 411 3 120-0

Efrk 401 Container

Behältertragwagen Lbs 589
"Südzucker" der DB
Container Car Lbs 589 "Südzucker" DB



Best.-Nr.
Order no. **49133**



Betriebs-Nr. | Road no.: 21 80 411 3 215-8

Efrk 401 Container

Behältertragwagen Lbs-58 "Erstes Kulmbacher
Actienbier" der DB
Container Car Lbs-58 "Erstes Kulmbacher Actienbier" DB



Best.-Nr.
Order no. **49114**



Betriebs-Nr. | Road no.: 020 024

Ddtkr 612 Container

Behältertragwagen BTmms 58 "Dinkelacker" der DB
Container Car BTmms 58 "Dinkelacker" DB



Best.-Nr.
Order no. **49115**



Betriebs-Nr. | Road no.: 020 131

Ddtkr 612 Container

Behältertragwagen BTmms 58 "Dortmunder Stifts-
Bier" der DB
Container Car BTmms 58 "Dortmunder Stifts-Bier" DB



Best.-Nr.
Order no. **49116**



Betriebs-Nr. | Road no.: 020 245

Ddtkr 612 Container

Behältertragwagen BTmms 58 "Von Haus zu Haus"
der DB
Container Car BTmms 58 "Von Haus zu Haus" DB



Best.-Nr.
Order no. **49120**



Betriebs-Nr. | Road no.: 020 018

Eoskrt 022 Container

Behältertragwagen Lbs-58 "Bahlsen" der DB
Container Car Lbs-58 "Bahlsen" DB



Best.-Nr.
Order no. **49124**



Betriebs-Nr. | Road no.: 020 144

Ekrt 212 Container

Behältertragwagen BTmms 58 "von Haus zu Haus"
der DB
Container Car BTmms 58 "von Haus zu Haus" DB



Best.-Nr.
Order no. **49128**



Betriebs-Nr. | Road no.: 020 156

DDIKR 621 Container

Behältertragwagen Lbs-58 "von Haus zu Haus" der DB
Container Car Lbs-58 "von Haus zu Haus" DB



Best.-Nr.
Order no. **49129**



Betriebs-Nr. | Road no.: 020 144

Ekrt 212 Container

Behältertragwagen Lbs 589 "Union Siegel-Pils" der DB
Container Car Lbs 589 "Union Siegel-Pils" DB



Best.-Nr.
Order no. **49110**



Betriebs-Nr. | Road no.: 21 80 411 3 309-9

Ddtkr 612 Container

Behältertragwagen Lbs 589 "Avia" der DB
Container Car Lbs 589 "Avia" DB



Best.-Nr.
Order no. **49119**



Betriebs-Nr. | Road no.: 21 80 411 3 055-8

Ddtkr 603 Container

Behältertragwagen Lbs 589 "Fricke Texaco" der DB
Container Car Lbs 589 "Fricke Texaco" DB



Best.-Nr.
Order no. **49121**



Betriebs-Nr. | Road no.: 21 80 411 3 120-0

Ddtkr 603 Container

Behältertragwagen Lbs 589 "DEA" der DB
Container Car Lbs 589 "DEA" DB



Best.-Nr.
Order no. **49122**



Betriebs-Nr. | Road no.: 21 80 411 3 187-9

Ddtkr 603 Container

Behältertragwagen Lbs 589 "von Haus zu Haus" der DB
Container Car Lbs 589 "von Haus zu Haus" DB



Best.-Nr. 49130
Order no.
Betriebs-Nr. | Road no.: 21 80 411 3 166-3

Ekrat 212 Container

Offener Mittelcontainer Eoskrt 022 "Von Haus zu Haus"
Open Medium Container Eoskrt 022 "Von Haus zu Haus"

© BRAWA



Best.-Nr. 94703
Order no.

Passend zu Behältertragwagen B1mms 58 | Suitable for Container Car B1mms 58

Behältertragwagen Lbms 589 "Von Haus zu Haus" der DB
Container Car Lbms 589 "Von Haus zu Haus" DB



Best.-Nr. 49127
Order no.
Betriebs-Nr. | Road no.: 21 80 411 2 248-0

Offener Mittelcontainer Eoskrt 022 "Von Haus zu Haus"
Open Medium Container Eoskrt 022 "Von Haus zu Haus"

© SEAG; SLG. S. CARSTENS



Best.-Nr. 94704
Order no.

Passend zu Behältertragwagen Lbs-58 | Suitable for Container Car Lbs-58



BESTENS AUSGESTATTET
Leuchten, Seilbahnen, zahlreiche Ausstattungs-
details und ein breites Sortiment an Elektrozubehör für
H0 und N finden Sie im BRAWA Zubehörkatalog.

PERFECTLY EQUIPPED
You can now find lamps, cable railways, a variety
of equipment details and a wide range of
electrical accessories for H0 and N in the BRAWA
accessories catalogue.



KESSELWAGEN Z [P] "ESSO" DER DRG

TANK CAR Z [P] "ESSO" DRG

VORBILDNAHER, OFFEN GESTALTETER RAHMEN
TRUE-TO-ORIGINAL OPEN CONSTRUCTED FRAME

ANGESETZTE
HANDBREMSSPINDEL
MOUNTED HAND BRAKE SPINDEL



Best.-Nr. 49205
Order no.

Betriebs-Nr. | Road no.: 527 610 [P]



KRUPP KESSELWAGEN

KRUPP TANK CAR

Kesselwagen ZZ [P] "Eva" der DB
Tank Car ZZ [P] "Eva" DB



Best.-Nr. 47413
Order no.
Betriebs-Nr. | Road no.: 540 717 [P]

Kesselwagen ZZ [P] "VTG" der DB
Tank Car ZZ [P] "VTG" DB



Best.-Nr. 47415
Order no.
Betriebs-Nr. | Road no.: 20 80 005 5 033-4 [P]

Kesselwagen ZE "Esso D.D.P.A" der DSB
Tank Car ZE "Esso D.D.P.A" DSB



Best.-Nr. 48856
Order no.
Betriebs-Nr. | Road no.: 502 282 [P]

Kesselwagen Z [P] "Danzas" der DB
Tank Car Z [P] "Danzas" DB



Best.-Nr. 49204
Order no.
Betriebs-Nr. | Road no.: 547 623

Kesselwagen SCwf "Locataire Naphtachimie" der SNCF
Tank Car SCwf "Locataire Naphtachimie" SNCF



Best.-Nr. 49217
Order no.
Betriebs-Nr. | Road no.: 7573826 [P]

Kesselwagen ZZ [P] "Eva" der DB
Tank Car ZZ [P] "Eva" DB



Best.-Nr. 47413
Order no.
Betriebs-Nr. | Road no.: 540 717 [P]

Kesselwagen ZZ [P] "VTG" der DB
Tank Car ZZ [P] "VTG" DB



Best.-Nr. 47415
Order no.
Betriebs-Nr. | Road no.: 20 80 005 5 033-4 [P]

Kesselwagen SCwf "Simotra / ESSO" der SNCF
Tank Car SCwf "Simotra / ESSO" SNCF



Best.-Nr. 49219
Order no.
Betriebs-Nr. | Road no.: 7596113 [P]

Kesselwagen Z [P] "staatsmijn creosootolie" der NS
Tank Car Z [P] "staatsmijn creosootolie" NS



Best.-Nr. 49227
Order no.
Betriebs-Nr. | Road no.: 515615 [P]

Kesselwagen Z [P] "Nieuwe Matex" der NS
Tank Car Z [P] "Nieuwe Matex" NS



Best.-Nr. 49228
Order no.
Betriebs-Nr. | Road no.: 510128 [P]

Kesselwagen SCwf "Lambiotte Freres" der SNCF
Tank Car SCwf "Lambiotte Freres" SNCF



Best.-Nr. Order no. **49229**

Betriebs-Nr. | Road no.: 569543 [P]

Kesselwagen Z [P] "IVG" der DB
Tank Car Z [P] "IVG" DB



Best.-Nr. Order no. **49233**

Betriebs-Nr. | Road no.: 5 526 648 [P]

Kesselwagen SCwf "Simotra" der SNCF
Tank Car SCwf "Simotra" SNCF



Best.-Nr. Order no. **49235**

Betriebs-Nr. | Road no.: 595282 [P]

Kesselwagen Z [P] "Merkur Transformatorenöl" der DB
Tank Car Z [P] "Merkur Transformatorenöl" DB



Best.-Nr. Order no. **49248**

Betriebs-Nr. | Road no.: 579 660 [P]

Kesselwagen Z [P] "OZO Ipsa Rotkreuz" der SBB
Tank Car Z [P] "OZO Ipsa Rotkreuz" SBB



Best.-Nr. Order no. **49252**

Betriebs-Nr. | Road no.: 533 926 [P]

Kesselwagen Z [P] "ESSO" der DB
Tank Car Z [P] "ESSO" DB



Best.-Nr. Order no. **49224**

Betriebs-Nr. | Road no.: 23 80 703 2 015-1 [P]

Kesselwagen Z [P] "OROP" der BBÖ
Tank Car Z [P] "OROP" BBÖ



Best.-Nr. Order no. **49238**

Betriebs-Nr. | Road no.: 532 880 [P]

Kesselwagen Z [P] "VTG" der DB
Tank Car Z [P] "VTG" DB



Best.-Nr. Order no. **49239**

Betriebs-Nr. | Road no.: 590 077 [P]

Kesselwagen Z [P] "Eva" der DB
Tank Car Z [P] "Eva" DB



Best.-Nr. Order no. **49241**

Betriebs-Nr. | Road no.: 503 317 [P]

Kesselwagen Z [P] "DEA" der DB
Tank Car Z [P] "DEA" DB



Best.-Nr. Order no. **49232**

Betriebs-Nr. | Road no.: 23 80 700 4 007-2 [P]

Kesselwagen Z [P] "Avia Osterwalder" der SBB
Tank Car Z [P] "Avia Osterwalder" SBB



Best.-Nr. Order no. **49237**

Betriebs-Nr. | Road no.: 20 85 111 8 101-7 [P]

Kesselwagen Z [P] "VTG" der DB
Tank Car Z [P] "VTG" DB



Best.-Nr. Order no. **49240**

Betriebs-Nr. | Road no.: 21 80 070 0 722-0 [P]

Kesselwagen Z [P] "MARTHA" der ÖBB
Tank Car Z [P] "MARTHA" ÖBB



Best.-Nr. Order no. **49244**

Betriebs-Nr. | Road no.: 519 137 [P]

Kesselwagen Z [P] "Luhns" der DB
Tank Car Z [P] "Luhns" DB



Best.-Nr. Order no. **49245**

Betriebs-Nr. | Road no.: 543 830 [P]

Kesselwagen Z [P] "PAM" der NS
Tank Car Z [P] "PAM" NS



Best.-Nr. Order no. **49246**

Betriebs-Nr. | Road no.: 501 309 [P]

Kesselwagen Z [P] "Eva" der DB
Tank Car Z [P] "Eva" DB



Best.-Nr. Order no. **49242**

Betriebs-Nr. | Road no.: 21 80 071 8 005-0 [P]

Kesselwagen Z [P] "Westfalen" der DB
Tank Car Z [P] "Westfalen" DB



Best.-Nr. Order no. **49243**

Betriebs-Nr. | Road no.: 21 80 000 7 096-9 [P]

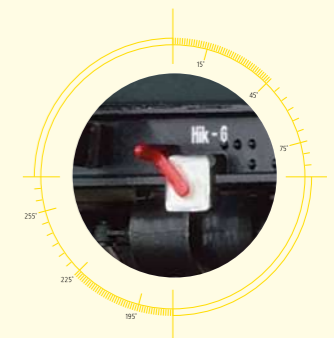

Kesselwagen Z [P] "Gulf Oil" der DSB
Tank Car Z [P] "Gulf Oil" DSB



Best.-Nr. Order no. **49247**

Betriebs-Nr. | Road no.: 20 86 070 1 232-4 [P]

Kesselwagen Z [P] "OEVA" der ÖBB
Tank Car Z [P] "OEVA" ÖBB



Best.-Nr. Order no. **49253**

Betriebs-Nr. | Road no.: 23 81 736 6 022-2 [P]

Kesselwagen Z [P] "VTG" der DB
Tank Car Z [P] "VTG" DB



Best.-Nr. Order no. **49234**

Betriebs-Nr. | Road no.: 23 80 735 0189-5 [P]

TAUCHEN SIE EIN IN EINE FASZINIERENDE ZEITREISE
MODEL RAILWAY HISTORY OF SPECIAL KIND



Sie suchen nach einem BRAWA Modell aus den vergangenen Jahren? Im BRAWA Online-Museum finden Sie eine umfangreiche Auswahl an Modellen, die heute nicht mehr ab Werk lieferbar sind. Wir wünschen Ihnen viel Spaß beim Entdecken unserer „historischen“ Modelle. | At the BRAWA Museum you will find an extensive selection of locomotives, railcars, passenger coaches and freight cars, that are no longer available ex works. We wish you much fun while discovering our "historic" models.

WWW.BRAWA.DE/FANWELT/ONLINE-MUSEUM



GEDECKTER GÜTERWAGEN GLMHS 50 DER DB

COVERED FREIGHT CAR GLMHS 50 DB



Best.-Nr. **47264**
Order no.

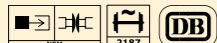

Betriebs-Nr. | Road no.: 212 244



- 1 BREMSBACKEN IN RADEBENE
BRAKE SHOES IN WHEEL PLANE
- 2 EXTRA ANGESETZTE BREMSANLAGE
EXTRA BRAKING SYSTEM
- 3 FEINSTE BEDRUCKUNG UND LACKIERUNG
FINEST PAINTWORK AND PRINTING

Gedeckter Güterwagen Gmhs 50 "Afri Cola" der DB
Covered Freight Car Gmhs 50 "Afri Cola" DB



Best.-Nr. **47272**
Order no.



Betriebs-Nr. | Road no.: 201 336

Gedeckter Güterwagen Gmhs 50 "Bluna" der DB
Covered Freight Car Gmhs 50 "Bluna" DB



Best.-Nr. **47273**
Order no.



Betriebs-Nr. | Road no.: 201 769

Gedeckter Güterwagen Gmhs 50 der DB
Covered Freight Car Gmhs 50 DB



Best.-Nr. **47277**
Order no.



Betriebs-Nr. | Road no.: 204 718

Gedeckter Güterwagen Gmhs 50 der DB
Covered Freight Car Gmhs 50 DB



Best.-Nr. **47278**
Order no.



Betriebs-Nr. | Road no.: 208 376

Gedeckter Güterwagen Gbs 245 der DB
Covered Freight Car Gbs 245 DB



Best.-Nr. **47265**
Order no.



Betriebs-Nr. | Road no.: 21 80 152 4 169-6

Gedeckter Güterwagen Gos der DR
Covered Freight Car Gos DR



Best.-Nr. **47266**
Order no.



Betriebs-Nr. | Road no.: 21 50 140 1027-3

Gedeckter Güterwagen Gos-uv 253 "Peugeot Talbot" der DB
Covered Freight Car Gos-uv 253 "Peugeot Talbot" DB



Best.-Nr. **47267**
Order no.



Betriebs-Nr. | Road no.: 21 80 141 4 413-1

Gedeckter Güterwagen Gbs 245 "Ültje" der DB
Covered Freight Car Gbs 245 "Ültje" DB



Best.-Nr. **47268**
Order no.



Betriebs-Nr. | Road no.: 21 80 154 5 028-9

Gedeckter Güterwagen Gbs-uv 253 "BASF Trocken Eis" der DB
Covered Freight Car Gbs-uv 253 "BASF Trocken Eis" DB



Best.-Nr. **47274**
Order no.



Betriebs-Nr. | Road no.: 25 80 141 4 412-9 [P]

Gedeckter Güterwagen Gbs-uv 253 "BASF Trocken Eis" der DB
Covered Freight Car Gbs-uv 253 "BASF Trocken Eis" DB



Best.-Nr. **47275**
Order no.



Betriebs-Nr. | Road no.: 16 80 114 5 503-5 [P]

Gedeckter Güterwagen Gbs 245 "Liebherr" der DB
Covered Freight Car Gbs 245 "Liebherr" DB



Best.-Nr. **47282**
Order no.



Betriebs-Nr. | Road no.: 21 80 140 5 672-3

Gedeckter Güterwagen Gos 253 der DB AG
Covered Freight Car Gos 253 DB AG



Best.-Nr. **47263**
Order no.



Betriebs-Nr. | Road no.: 21 80 141 3 544-4

Gedeckter Güterwagen Gbs 245 der Wiebe
Covered Freight Car Gbs 245 Wiebe



Best.-Nr. **47284**
Order no.



Betriebs-Nr. | Road no.: 60 80 0923 742-1





GEDECKTER ZWEIACHSER HBIS IMMER BESTENS BELADEN

COVERED TWIN AXLE HBIS
ALWAYS BEST FOR LOADING

Gedeckter Güterwagen Hbis "Post" der DSB
Covered Freight Car Hbis "Post" DSB



Best.-Nr. **48978**
Order no.

Betriebs-Nr. | Road no.: 46 86 225 0 440-4

Gedeckter Güterwagen Hbis 299 "Kaldewei" der DB
Covered Freight Car Hbis 299 "Kaldewei" DB



Best.-Nr. **48984**
Order no.

Betriebs-Nr. | Road no.: 21 80 211 6 534-4

Gedeckter Güterwagen Hbis 297 der DB
Covered Freight Car Hbis 297 DB



Best.-Nr. **48985**
Order no.

Betriebs-Nr. | Road no.: 21 80 211 7 994-8

Gedeckter Güterwagen Hbis 299 "Miele" der DB
Covered Freight Car Hbis 299 "Miele" DB



Best.-Nr. **48987**
Order no.

Betriebs-Nr. | Road no.: 21 80 201 6 117-8

Gedeckter Güterwagen Hbis 299 "Krupp" der DB
Covered Freight Car Hbis 299 "Krupp" DB



Best.-Nr. **48990**
Order no.

Betriebs-Nr. | Road no.: 21 80 225 4 644-2

Gedeckter Güterwagen Klmmgs 299 "Hella" der DB
Covered Freight Car Klmmgs 299 "Hella" DB



Best.-Nr. **48991**
Order no.

Betriebs-Nr. | Road no.: 21 80 201 5 164-1

Gedeckter Güterwagen Hbills 299 der DB AG
Covered Freight Car Hbills 299 DB AG



Best.-Nr. **48988**
Order no.

Betriebs-Nr. | Road no.: 21 80 235 4 506-2

Gedeckter Güterwagen Hbis "Grand Danois" der DSB
Covered Freight Car Hbis "Grand Danois" DSB



Best.-Nr. **48979**
Order no.

Betriebs-Nr. | Road no.: 21 86 225 0 209-2

Gedeckter Güterwagen Hbills-x 299 "Telefunken" der DB
Covered Freight Car Hbills-x 299 "Telefunken" DB



Best.-Nr. **48989**
Order no.

Betriebs-Nr. | Road no.: 21 80 2276 689-1

GEDECKTER GÜTERWAGEN G10 "NIVEA" DER DRG

COVERED FREIGHT CAR G10 "NIVEA" DRG



Best.-Nr. **49032**
Order no.

Betriebs-Nr. | Road no.: 520 798 [P]

Gedeckter Güterwagen Gm der K.W.St.E.
Covered Freight Car Gm K.W.St.E.



Best.-Nr. **49722**
Order no.

Betriebs-Nr. | Road no.: Württemberg 29 645

Gedeckter Güterwagen Nm der K.P.E.V.
Covered Freight Car Nm K.P.E.V.



Best.-Nr. **49723**
Order no.

Betriebs-Nr. | Road no.: Magdeburg 13 265

Gedeckter Güterwagen Nm "Erdal" der K.P.E.V.
Covered Freight Car Nm "Erdal" K.P.E.V.



Best.-Nr. **49742**
Order no.

Betriebs-Nr. | Road no.: 12 455

Gedeckter Güterwagen Kassel "Fleischwarenfabrik Oldenburg" der DRG
Covered Freight Car Kassel "Fleischwarenfabrik Oldenburg" DRG



Best.-Nr. **49768**
Order no.

Betriebs-Nr. | Road no.: 589 328 [P]

Gedeckter Güterwagen G der DRG
Covered Freight Car G DRG



Best.-Nr. **49718**
Order no.

Betriebs-Nr. | Road no.: 30 117

Gedeckter Güterwagen G Karlsruhe "Fischer Bräu" der DRG
Covered Freight Car G Karlsruhe "Fischer Bräu" DRG



Best.-Nr. **49728**
Order no.

Betriebs-Nr. | Road no.: 545 295 [P]

Gedeckter Güterwagen Bierwagen "Mousel Bieres" der CFL
Covered Freight Car Bierwagen "Mousel Bieres" CFL



Best.-Nr. **49758**
Order no. **49758**

Betriebs-Nr. | Road no.: 500 016 [P]

Gedeckter Güterwagen G10 "Persil" der DB
Covered Freight Car G10 "Persil" DB



Best.-Nr. **49754**
Order no. **49754**

Betriebs-Nr. | Road no.: 125 073

Gedeckter Güterwagen G "Konsum" der DR
Covered Freight Car G "Konsum" DR



Best.-Nr. **49764**
Order no. **49764**

Betriebs-Nr. | Road no.: 04-24-66

Gedeckter Güterwagen G10 "Doornkaat" der Brit-US-Zone
Covered Freight Car G10 "Doornkaat" Brit-US-Zone



Best.-Nr. **49091**
Order no. **49091**

Betriebs-Nr. | Road no.: 135 398

WWW.BRAWA.DE

Ausführliche Informationen zu unseren Produkten und Services finden Sie auf der BRAWA Website – wir wünschen Ihnen viel Spaß beim Entdecken zahlreicher Details!

More information about our products and services is available on the BRAWA website. We wish you much fun while discovering lots of details!

Gedeckter Güterwagen G10 "Hansplast" der DB
Covered Freight Car G10 "Hansplast" DB



Best.-Nr. **49035**
Order no. **49035**

Betriebs-Nr. | Road no.: 126 534

Gedeckter Güterwagen G10 "Pattex" der DB
Covered Freight Car G10 "Pattex" DB

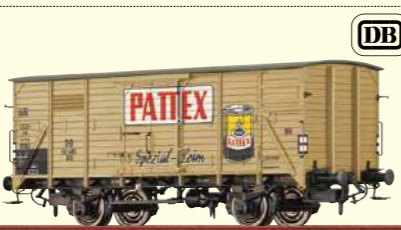

Best.-Nr. **49036**
Order no. **49036**

Betriebs-Nr. | Road no.: 132 485

Gedeckter Güterwagen G10 "Berentzen" der DB
Covered Freight Car G10 "Berentzen" DB



Best.-Nr. **49045**
Order no. **49045**

Betriebs-Nr. | Road no.: 125 334

Gedeckter Güterwagen G10 "Felix" der DB
Covered Freight Car G10 "Felix" DB



Best.-Nr. **49711**
Order no. **49711**

Betriebs-Nr. | Road no.: 136 350

Gedeckter Güterwagen G "Versuchswagen" der DR
Covered Freight Car G "Versuchswagen" DR



Best.-Nr. **49712**
Order no. **49712**

Betriebs-Nr. | Road no.: 05-19-69

Gedeckter Güterwagen IE der DSB
Covered Freight Car IE DSB



Best.-Nr. **49720**
Order no. **49720**

Betriebs-Nr. | Road no.: 18 791

Gedeckter Güterwagen G10 "UNOX" der NS
Covered Freight Car G10 "UNOX" NS



Best.-Nr. **49063**
Order no. **49063**

Betriebs-Nr. | Road no.: 554 627 [P]

Gedeckter Güterwagen G10 "Fritz Homann" der DB
Covered Freight Car G10 "Fritz Homann" DB



Best.-Nr. **49074**
Order no. **49074**

Betriebs-Nr. | Road no.: 525 330 [P]

Gedeckter Güterwagen G10 "EUROP" der SNCB
Covered Freight Car G10 "EUROP" SNCB



Best.-Nr. **49077**
Order no. **49077**

Betriebs-Nr. | Road no.: 296691

Gedeckter Güterwagen G10 der DB
Covered Freight Car G10 DB



Best.-Nr. **49721**
Order no. **49721**

Betriebs-Nr. | Road no.: 126 263

Gedeckter Güterwagen Kf2 "EUROP" der SNCF
Covered Freight Car Kf2 "EUROP" SNCF



Best.-Nr. **49726**
Order no. **49726**

Betriebs-Nr. | Road no.: 7310011

Gedeckter Güterwagen G10 "Caramba Öl" der DB
Covered Freight Car G10 "Caramba Öl" DB



Best.-Nr. **49729**
Order no. **49729**

Betriebs-Nr. | Road no.: 133 343



Gedeckter Güterwagen G10 "Kühne" der DB
Covered Freight Car G10 "Kühne" DB



Best.-Nr. **49730**
Order no. **49730**

Betriebs-Nr. | Road no.: 131 238

Gedeckter Güterwagen G10 "Knorr" der DB
Covered Freight Car G10 "Knorr" DB



Best.-Nr. **49732**
Order no. **49732**

Betriebs-Nr. | Road no.: 137 311

Gedeckter Güterwagen G "Aldersbach" der DB
Covered Freight Car G "Aldersbach" DB



Best.-Nr. **49736**
Order no. **49736**

Betriebs-Nr. | Road no.: 519 025 [P]

Gedeckter Güterwagen G10 "UHU" der DB
Covered Freight Car G10 "UHU" DB



Best.-Nr. **49739**  

Betriebs-Nr. | Road no.: 129 399

Gedeckter Güterwagen G10 "Zwilling" der DB
Covered Freight Car G10 "Zwilling" DB





Best.-Nr. **49740**  

Betriebs-Nr. | Road no.: 130 003

Gedeckter Güterwagen ZB "Albani" der DSB
Covered Freight Car ZB "Albani" DSB



Best.-Nr. **49751**  

Betriebs-Nr. | Road no.: 99 688 [P] 

Gedeckter Güterwagen QB der TKVJ
Covered Freight Car QB TKVJ



Best.-Nr. **49759**  

Betriebs-Nr. | Road no.: 301

Gedeckter Güterwagen G "Lambertz" der DB
Covered Freight Car G "Lambertz" DB



Best.-Nr. **49760**  

Betriebs-Nr. | Road no.: 53 250

Gedeckter Güterwagen G10 "Wick" der DB
Covered Freight Car G10 "Wick" DB



Best.-Nr. **49765**  

Betriebs-Nr. | Road no.: 123 400



Gedeckter Güterwagen G10 "WMF" der DB
Covered Freight Car G10 "WMF" DB



EXTRA ANGESETZTE TÜRRIEGEL
EXTRA DOOR LATCHES

UNTERBODEN MIT EXTRA ANGESETZTER BREMSANLAGE
UNDERCARRIAGE WITH EXTRA BRAKE SYSTEM

EPOCHENGERECHTE VARIANTE DES BREMSERHAUSESE
TRUE-TO-EPOCH VARIANT OF THE BRAKEMAN'S CAB

Best.-Nr. **49741**  

Betriebs-Nr. | Road no.: 128 296

Gedeckter Güterwagen Bierwagen "Kulmbacher UNIMA Malzfabrikat" der DB
Covered Freight Car Bierwagen "Kulmbacher UNIMA Malzfabrikat" DB



Best.-Nr. **49766**  

Betriebs-Nr. | Road no.: 521 582 [P]

Gedeckter Güterwagen G10 "Zentis" der DB
Covered Freight Car G10 "Zentis" DB



Best.-Nr. **49769**  

Betriebs-Nr. | Road no.: 144 275

Gedeckter Güterwagen G10 "Milkana" der DB
Covered Freight Car G10 "Milkana" DB



Best.-Nr. **49771**  

Betriebs-Nr. | Road no.: 145 387

Gedeckter Güterwagen G10 "Melitta" der DB
Covered Freight Car G10 "Melitta" DB



Best.-Nr. **49772**  

Betriebs-Nr. | Road no.: 134 108

Gedeckter Güterwagen Bierwagen "Brouwerij de 3 Hoefuzers" der NS
Covered Freight Car Bierwagen "Brouwerij de 3 Hoefuzers" NS



Best.-Nr. **49776**  

Betriebs-Nr. | Road no.: 560 707 [P] 

Gedeckter Güterwagen G "Anker-Brot" der ÖBB
Covered Freight Car G "Anker-Brot" ÖBB



Best.-Nr. **49056**  

Betriebs-Nr. | Road no.: 163 595 

Gedeckter Güterwagen G10 "Sunil" der DB
Covered Freight Car G10 "Sunil" DB



Best.-Nr. **49752**  

Betriebs-Nr. | Road no.: 118 052

Gedeckter Güterwagen G10 "Tefal" der DB
Covered Freight Car G10 "Tefal" DB



Best.-Nr. **49755**  

Betriebs-Nr. | Road no.: 123 660

Gedeckter Güterwagen G10 "Hella" der DB
Covered Freight Car G10 "Hella" DB



Best.-Nr. **49756**  

Betriebs-Nr. | Road no.: 124 601

Gedeckter Güterwagen KKu der SNCF
Covered Freight Car KKu SNCF



Best.-Nr. **49095**  

Betriebs-Nr. | Road no.: 277 669 

Gedeckter Güterwagen Hif "BRASSERIE METEOR" der SNCF
Covered Freight Car Hif "BRASSERIE METEOR" SNCF



Best.-Nr. **49701**  

Betriebs-Nr. | Road no.: 505250 [P] 

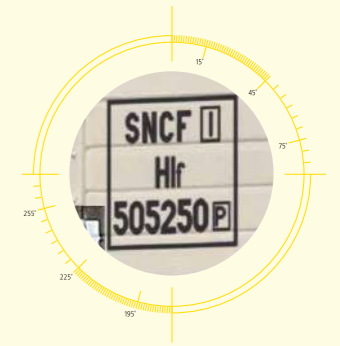

Gedeckter Güterwagen Kühlwagen "Heinrich Baumgarten" der Brit-US-Zone
 Covered Freight Car Kühlwagen "Heinrich Baumgarten"
 Brit-US-Zone



Best.-Nr. Order no. **49767** III
 Betriebs-Nr. | Road no.: 620 199 [P]

Gedeckter Güterwagen Gk1m 191 der DB
 Covered Freight Car Gk1m 191 DB



Best.-Nr. Order no. **49719** IV
 Betriebs-Nr. | Road no.: 20 80 112 1 979-6

Ged. Güterwagen 1121 "Materialkurswagen" der DR
 Covered Freight Car 1121 "Materialkurswagen" DR



Best.-Nr. Order no. **49725** IV
 Betriebs-Nr. | Road no.: 40 50 943 1104-1



6-ACHSIGER KESSELWAGEN ZUM TRANSPORT VON CHEMISCHEN STOFFEN

SIX-AXLE TANK CARS
 FOR THE TRANSPORT OF CHEMICAL SUBSTANCES

Kesselwagen ZZd [P] "Chemische Werke Hüls AG" der DB
 Tank Car ZZd [P] "Chemische Werke Hüls AG" DB



Best.-Nr. Order no. **48538** III
 Betriebs-Nr. | Road no.: 509 233 [P]

Kesselwagen ZZd [P] "Farbwerke Hoechst" der DB
 Tank Car ZZd [P] "Farbwerke Hoechst" DB



Best.-Nr. Order no. **48540** III
 Betriebs-Nr. | Road no.: 516 234

Kesselwagen ZZd [P] "Bayer A.G." der DB
 Tank Car ZZd [P] "Bayer A.G." DB



Best.-Nr. Order no. **48536** IV
 Betriebs-Nr. | Road no.: 21 80 006 1 513-6 [P]

WWW.BRAWA.DE



BEDIENUNGSANLEITUNGEN
 Sie möchten ein Modell warten und haben die Bedienungsanleitung verlegt? Sie suchen ein Ersatzteil? Auf unserer Website werden Sie fündig. Einfach Bestell-Nummer eingeben und Liste downloaden.

MANUALS
 Do you want to perform maintenance on a model but have lost the instruction manual? Are you looking for a spare part? Our website is the place to find them. Simply note the order no. and download the list.

Offener Güterwagen Om 21 "EUROP" der DB
 Open Freight Car Om 21 "EUROP" DB



Best.-Nr. Order no. **48433** III
 Betriebs-Nr. | Road no.: 750 967

Offener Güterwagen Om 21 der DB
 Open Freight Car Om 21 DB



Best.-Nr. Order no. **48435** III
 Betriebs-Nr. | Road no.: 756 328

Offener Güterwagen Om 21 "Kaldewei" der DB
 Open Freight Car Om 21 "Kaldewei" DB



Best.-Nr. Order no. **48438** III
 Betriebs-Nr. | Road no.: 751 281

Offener Güterwagen Omu (O) der DR
 Open Freight Car Omu (O) DR



Best.-Nr. Order no. **48434** IV
 Betriebs-Nr. | Road no.: 21 50 559 6257-9

Gedeckter Güterwagen GGhrs der DR
 Covered Freight Car GGhrs DR



Best.-Nr. Order no. **48393** III
 Betriebs-Nr. | Road no.: 15-53-20

Gedeckter Güterwagen GGhrs der DR
 Covered Freight Car GGhrs DR



Best.-Nr. Order no. **48395** III
 Betriebs-Nr. | Road no.: 15-55-15

Gedeckter Güterwagen Gags-v der DR
 Covered Freight Car Gags-v DR



Best.-Nr. Order no. **48394** IV
 Betriebs-Nr. | Road no.: 11 50 199 2525-0

GEDECKTER VIERACHSER GAGS IMMER BESTENS BELADEN

COVERED FOUR AXLE GAGS
 ALWAYS BEST FOR LOADING



SÄURETOPFWAGEN Z [P] "VTG" DER DB

ACID CARRYING CAR Z [P] "VTG" DB

EXTRA ANGESETZTE ANSCHRIFTENTAFELN
SEPARATELY MOUNTED ADDRESS PLATES

SÄURETÖPFE MIT
FREISTEHENDEN VERSCHLÜSSEN
ACID CONTAINERS WITH SINGLE-STANDING
LOCKING DEVICES

FEIN GRAVIERTE BRETTERFUGEN
FILIGREE REPLICA OF THE BODY



Best.-Nr.
Order no. **49301**

Betriebs-Nr. | Road no.: 21 80 090 0 104-9 [P]



Alle Abb. zeigen Illustrationen | All pictures show illustrations

D – Für den Transport von aggressiven Flüssigkeiten, wie Säuren waren Kesselwagen lange Zeit ungeeignet. Zwar gab es bereits in den zwanziger Jahren des vorigen Jahrhunderts Kessel mit einer Gummiauskleidung, trotzdem wurden in der Regel zum Transport solcher Güter Topfwagen benutzt. Dabei verwendeten die Waggonbauunternehmen meistens das Untergestell der Verbandsbauart mit 4,00m oder 4,50m Achsstand und ordneten darauf zehn oder zwölf Steinguttöpfe mit je 1000 – 1200 Fassungsvermögen an. Die Töpfe werden von Holz- und Gummibeilagen gehalten, die Kastenstützen sind durch Diagonalstreben versteift. Viele kleine oder größere chemische Unternehmen hatten solche Wagen bei der jeweiligen Bahndirektion als Privat-Wageneingestellt. In der BRD stiftete die Degussa 1985 ihren letzten Topfwagen dem Eisenbahnmuseum Bochum-Dahlhausen. Bei der DR konnten Topfwagen noch 1990 im Einsatz beobachtet werden, mehrere Vereine haben erhaltene Wagen im Bestand, so unter anderem in Aschersleben, Magdeburg und Staßfurt.

EN – For a long time, tank wagons were unsuitable for the transport of aggressive liquids such as acids. Although boilers equipped with a rubber cladding were available as early as the 1920s, acid wagons were still generally used in order to transport such goods. In doing so, the wagon construction companies used the undercarriage of the standard layout wagon with a wheel base of 4.00 m or 4.50 m and arranged ten or twelve earthenware containers, each with a filling capacity of between 1000 and 1200 L. The containers were held in place using wood and rubber attachments and the box supports were reinforced using diagonal braces. Many small and large chemical companies used such wagons as private wagons at their respective railway directorate. In the FRG, Degussa donated its last acid wagon to the Bochum-Dahlhausen Railway Museum in 1985. Acid wagons were still used at the DR until 1990 and several clubs still own retained wagons such as those in Aschersleben, Magdeburg and Staßfurt.

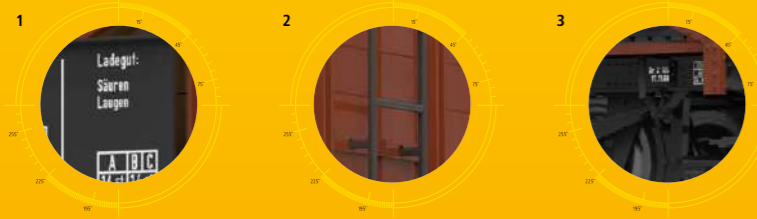

- 1 FEINSTE BEDRUCKUNG UND LACKIERUNG**
FINEST PAINTWORK AND PRINTING
- 2 EINZELN ANGESETZTE AUFSTIEGE UND TRITTE**
EXTRA MOUNTED STEPS
- 3 FILIGRANE NACHBILDUNG DES WAGENAUFBAUS**
FILIGREE REPLICA OF THE BODY

Säuretopfwagen Z [P] "Farwerke Hoechst AG" der DB

Acid Carrying Car Z [P] "Farwerke Hoechst AG" DB



Best.-Nr.
Order no. **49300**

Betriebs-Nr. | Road no.: 546 504 [P]



Säuretopfwagen Z "Koninklijke Zwavelzuur Fabrieken" der NS

Acid Carrying Car Z "Koninklijke Zwavelzuur Fabrieken" NS



Best.-Nr.
Order no. **49305**

Betriebs-Nr. | Road no.: 520 218 [P]



Säuretopfwagen Zs "Dansk Svovlsyre-OG" der DSB

Acid Carrying Car Zs "Dansk Svovlsyre-OG" DSB



Best.-Nr.
Order no. **49306**

Betriebs-Nr. | Road no.: 508 060 [P]



Säuretopfwagen Z "VEB Bitterfeld" der DR

Acid Carrying Car Z "VEB Bitterfeld" DR



Best.-Nr.
Order no. **49311**

Betriebs-Nr. | Road no.: 53-72-04 [P]



Säuretopfwagen SPw "Saint-Gobain" der SNCF

Acid Carrying Car SPw "Saint-Gobain" SNCF



Best.-Nr.
Order no. **49308**

Betriebs-Nr. | Road no.: 506485 [P]



Säuretopfwagen Z [P] "Ögussa" der BBÖ

Acid Carrying Car Z [P] "Ögussa" BBÖ



Best.-Nr.
Order no. **49309**

Betriebs-Nr. | Road no.: 502 457 [P]



Säuretopfwagen Z der DR

Acid Carrying Car Z DR



Best.-Nr.
Order no. **49304**

Betriebs-Nr. | Road no.: 21 50 071 6330-0



BESTENS AUSGESTATTET
Leuchten, Seilbahnen, zahlreiche Ausstattungsdetails und ein breites Sortiment an Elektrozubehör für HO und N finden Sie im BRAWA Zubehörkatalog.

PERFECTLY EQUIPPED
You can now find lamps, cable railways, a variety of equipment details and a wide range of electrical accessories for HO and N in the BRAWA accessories catalogue.



HO

N

*

GEDECKTER GÜTERWAGEN GLMMS DER DR

COVERED FREIGHT CAR GLMMS DR



DURCHBROCHENE WAGENKASTENSTÜTZE
PERFORATED COACH BODY SUPPORTS

DREIDIMENSIONALER RAHMENAUFBAU
THREE-DIMENSIONAL FRAME BODY

EINZELN ANGESETZTE STIRNPROFILE
INDIVIDUALLY MOUNTED FOREHEAD PROFILE



Best.-Nr. 49900
Order no.



Betriebs-Nr. | Road no.: 21 50 150 0124-5

D – Güterwagen wurden und werden bei der Bahn immer gebraucht. Die Deutschen Reichsbahn (DR) konnte in den 1950ern durch Umbauten und Modernisierung zwar kurzfristig Abhilfe schaffen, langfristig war man sich jedoch klar, dass andere Lösungen hermussten. Das RAW „Einheit“ Leipzig entwarf daher 1965 einen im Wesentlichen den Vereinheitlichungsmerkmalen nach UIC-Merkblatt entsprechenden Glmms Wagen. Die durch einen Probewagen gewonnene Erkenntnisse flossen in die ab 1968 produzierten Serienwagen ein, welche nun als Glmms 14.05 (später Gbs 1500) bezeichnet wurden. Der Aufbau, mit seinen markanten gesickten Seitenwänden, entstand komplett als Schweißkonstruktion. Die Seitenwände sind dabei bis auf die Unterkante der Rahmenaußenlangträger heruntergezogen und die Kastenprofile mit ihr verschweißt. Dadurch konnten die seitlichen Kastenstützen vereinfacht werden. Um beim Verladen Beschädigungen der Blechwände zu vermeiden, kleidete man die Wagen innen mit Holz aus. Der Boden bestand aus üblichen Kieferbohlen und war für die Beladung mit Gabelstaplern geeignet. Basierend auf der in über 17.000 Stück gebauten Gbs 1500 Konstruktion, entstanden in der Folgezeit verschiedene weitere Varianten wie Wärmeschutzwagen, Expressgutwagen oder Mannschaftswagen. Da die Produktionskapazität der eigenen Werke hier an ihre Grenzen stieß, ließ man auch im angrenzenden Ausland und sogar Spanien Wagen herstellen. Durch die RIV, MC bzw. OPW-Verkehr Tauglichkeit waren die Wagen relativ freizügig über die Landesgrenzen der DDR hinaus einsetzbar und waren somit auch schon vor der Wende häufig in Zügen der Bundesbahn zu beobachten. Bis zur Gründung der DB AG waren noch immer ca. 7.000 Wagen im Einsatz.

EN – Freight cars have always been required on the railways, now as in the past. The Deutsche Reichsbahn (DR) was able to provide a short-term remedy in the 1950s through retrofitting and modernisation, but it was clear that other solutions would have to be found in the long-term. As a result, in 1965 the Leipzig RAW "unit" designed a Glmms car which complied substantially with the standard characteristics of the UIC leaflet. The lessons learned from the test locomotives were incorporated in the series wagon produced from 1968, which was now known as Glmms 14.05 (later Gbs 1500). The design, with its distinctive corrugated side panels, came into being as a fully welded structure. The side panels were moved down onto the lower edge of the external body solebar and welded to the box profiles. This allowed for simplified side body supports. In order to prevent damage to the sheet metal walls during loading, the wagons were lined internally with wood. The floor consisted of standard pine planks and was suitable for loading with a forklift. Based on the Gbs 1500 design, of which over 1700 units were manufactured, a number of different versions were produced, including insulated boxcars, express goods wagons and vestibule cars. Since production capacity was almost exhausted at domestic facilities, wagons were also constructed in neighbouring countries and even Spain. Due to their RIV, MC and OPW transport suitability, the wagons could be used with relative freedom outside the DDR and were therefore often seen in Bundesbahn trains even before the fall of the Iron Curtain. However, until DB AG was founded, there were still as many as 7,000 wagons in use.



Gedeckter Güterwagen Gbs [1500] der DR
Covered Freight Car Gbs [1500] DR



Best.-Nr. 49901
Order no.



Betriebs-Nr. | Road no.: 01 50 150 2975-2

Gedeckter Güterwagen Ibbllps [8256] "Interfrigo Kühlwagen" der DR
Covered Freight Car Ibbllps [8256] "Interfrigo Kühlwagen" DR



Best.-Nr. 49902
Order no.



Betriebs-Nr. | Road no.: 01 50 825 6184-4

Gedeckter Güterwagen Gbs-t [1530] der DR
Covered Freight Car Gbs-t [1530] DR



Best.-Nr. 49904
Order no.



Betriebs-Nr. | Road no.: 20 50 153 0050-7

Gedeckter Güterwagen Hbs [2301] "Mannschaftswagen" der DR
Covered Freight Car Hbs [2301] "Mannschaftswagen" DR



Best.-Nr. 49906
Order no.



Betriebs-Nr. | Road no.: 27 50 230 0156-1

Gedeckter Güterwagen Gbs 258 der DB AG
Covered Freight Car Gbs 258 DB AG



Best.-Nr. 49903
Order no.



Betriebs-Nr. | Road no.: 01 80 152 4 404-1

Gedeckter Güterwagen Gbs 258 der DB AG
Covered Freight Car Gbs 258 DB AG



Best.-Nr. 49907
Order no.



Betriebs-Nr. | Road no.: 01 80 151 6 113-8

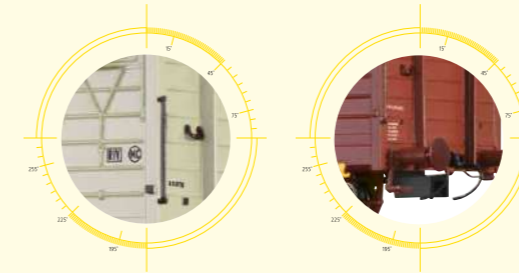

Gedeckter Güterwagen Gbs 258 der DB AG
Covered Freight Car Gbs 258 DB AG



Best.-Nr. 49908
Order no.



Betriebs-Nr. | Road no.: 01 80 152 5 437-0



GEDECKTER GÜTERWAGEN TDGS-V 930 "DB CARGO" DER DB AG

COVERED FREIGHT CAR TDGS-V 930 "DB CARGO" DB AG



Best.-Nr. 49512
Order no.

Betriebs-Nr. | Road no.: 21 80 014 8 202-3

Gedeckter Güterwagen Tds 241 der NS
Covered Freight Car Tds 241 NS



Best.-Nr. 49528
Order no.

Betriebs-Nr. | Road no.: 21 84 573 0 102-4

Gedeckter Güterwagen Tdgs 930 "K+S Kali" der DB
Covered Freight Car Tdgs 930 "K+S Kali" DB



Best.-Nr. 49531
Order no.

Betriebs-Nr. | Road no.: 21 80 574 1 483-9

Gedeckter Güterwagen Tds 930 der DB AG
Covered Freight Car Tds 930 DB AG



Best.-Nr. 49511
Order no.

Betriebs-Nr. | Road no.: 21 80 072 2 840-4

Gedeckter Güterwagen Tdgs 930 "Quarzwerke" der DB
Covered Freight Car Tdgs 930 "Quarzwerke" DB



Best.-Nr. 49530
Order no.

Betriebs-Nr. | Road no.: 21 80 074 1 369-1

Gedeckter Güterwagen Tds "Rail Cargo Austria" der ÖBB
Covered Freight Car Tds "Rail Cargo Austria" ÖBB



Best.-Nr. 49529
Order no.

Betriebs-Nr. | Road no.: 21 81 073 2 104-2

WWW.BRAWA.DE



- 1 FEIN GRAVIERTE ACHSLAGER UND FEDERPAKETE
FINELY ENGRAVED AXLE BEARINGS AND SPRING ASSEMBLIES
- 2 EINZELN ANGESETZTE GRIFSTANGEN UND TRITTE
EXTRA MOUNTED HANDRAILS AND STEPS
- 3 FEINSTE BEDRUCKUNG UND LACKIERUNG
FINEST PAINTWORK AND PRINTING

Gedeckter Güterwagen Uds-v der NS
Covered Freight Car Uds-v NS



Best.-Nr. 49516
Order no.

Betriebs-Nr. | Road no.: 95023

Gedeckter Güterwagen Uds-v der DSB
Covered Freight Car Uds-v DSB



Best.-Nr. 49515
Order no.

Betriebs-Nr. | Road no.: 21 86 574 0 293-7

Gedeckter Güterwagen Eds Type 1000 D1 der SNCB
Covered Freight Car Eds Type 1000 D1 SNCB



Best.-Nr. 49517
Order no.

Betriebs-Nr. | Road no.: 21 88 573 0 213-5





Offener Güterwagen Fds der NS
Open Freight Car Fds NS



Best.-Nr. Order no. **49506** 
Betriebs-Nr. | Road no.: 50081 



Offener Güterwagen Eds der ÖBB, 3er-Set
Open Freight Car Eds ÖBB, set of 3



Best.-Nr. Order no. **49505** 
Betriebs-Nr. | Road no.: 01 81 550 0 992-3; 01 81 550 1 912-6; 01 81 550 0 807-3 



Offener Güterwagen Eds der CFL
Open Freight Car Eds CFL



Best.-Nr. Order no. **49507** 
Betriebs-Nr. | Road no.: 01 82 550 5 247-6 



Offener Güterwagen Eds Type 1000 E2 der SNCB
Open Freight Car Eds Type 1000 E2 SNCB



Best.-Nr. Order no. **49508** 
Betriebs-Nr. | Road no.: 01 88 550 3 918-8 

Offener Güterwagen Ed 090 der DB
Open Freight Car Ed 090 DB



Best.-Nr. Order no. **49519** 
Betriebs-Nr. | Road no.: 01 80 541 8 151-8 



Offener Güterwagen Eds-v der NS
Open Freight Car Eds-v NS



Best.-Nr. Order no. **49524** 
Betriebs-Nr. | Road no.: 21 84 551 0 231-7 



Offener Güterwagen Fcs 090 der DB
Open Freight Car Fcs 090 DB



Best.-Nr. Order no. **49525** 
Betriebs-Nr. | Road no.: 01 80 635 5 447-3 



Offener Güterwagen Fcs 092 der DB AG
Open Freight Car Fcs 092 DB AG



Best.-Nr. Order no. **49526** 
Betriebs-Nr. | Road no.: 01 80 646 0 119-0 



Offener Güterwagen Fcs 092 der DB AG
Open Freight Car Fcs 092 DB AG



Best.-Nr. Order no. **49503** 
Betriebs-Nr. | Road no.: 21 80 6458 876-5 



Offener Güterwagen Fcs der ÖBB
Open Freight Car Fcs ÖBB



Best.-Nr. Order no. **49520** 
Betriebs-Nr. | Road no.: 21 81 6453 005-5 

Offener Güterwagen Fcs der CFL
Open Freight Car Fcs CFL



Best.-Nr. Order no. **49523** 
Betriebs-Nr. | Road no.: 21 82 645 0 241-8 



Güterzuggepäckwagen Pg (pr Iia 13a) der P.St.E.V.
Freight Car Pg (pr Iia 13a) P.St.E.V.



Best.-Nr. Order no. **49400** 
Betriebs-Nr. | Road no.: Osten 4021 



Güterzuggepäckwagen Pg (pr Iia 13a) der K.P.E.V.
Freight Car Pg (pr Iia 13a) K.P.E.V.



Best.-Nr. Order no. **49412** 
Betriebs-Nr. | Road no.: Essen 5105 



Güterzuggepäckwagen Pwg pr 14 der DRG
Freight Car Pwg pr 14 DRG



Best.-Nr. Order no. **49410** 
Betriebs-Nr. | Road no.: 123 318 Nürnberg 



Güterzuggepäckwagen D der CSD
Freight Car D 7SD



Best.-Nr. Order no. **49406** 
Betriebs-Nr. | Road no.: 6-2475 



Güterzuggepäckwagen Pwg pr 14 der BBÖ
Freight Car Pwg pr 14 BBÖ



Best.-Nr. Order no. **49408** 
Betriebs-Nr. | Road no.: 75 117 



Güterzuggepäckwagen Pwg pr 14 der DR
Freight Car Pwg pr 14 DR



Best.-Nr. Order no. **49411** 
Betriebs-Nr. | Road no.: 88-74-47 



Güterzuggepäckwagen Pwg 14 der DB
Freight Car Pwg 14 DB



Best.-Nr. Order no. **49415** 
Betriebs-Nr. | Road no.: 118 329 Hannover 



Güterzuggepäckwagen Pwg der DR
Freight Car Pwg DR



Best.-Nr. Order no. **49405** 
Betriebs-Nr. | Road no.: 88-31-04 

Güterzuggepäckwagen Pwg der DR
Freight Car Pwg DR



Best.-Nr. Order no. **49414** 
Betriebs-Nr. | Road no.: 30 50 940 2265-7 

GÜTERZUGBEGLEITWAGEN PWG 14

ACCOMPANYING WAGONS PWG 14





KESSELWAGEN ZZ [P] "ARAL" DER DB

TANK CAR ZZ [P] "ARAL" DB

ORIGINAL WIEDERGEWEBENER,
AUFBAU DES LEICHTBAURAHMENS
ORIGINALLY REPRODUCED LIGHTWEIGHT
FRAME BODY

EXTRA ANGESETZTER LAUFSTEG AM KESSEL
EXTRA WALKWAY ON THE BOILER

ACHSLAGERDECKEL MIT
ERHABENEN HERSTELLERANGABEN
AXLE BEARING COVER WITH
STANDING OUT MANUFACTURER'S INFORMATION



Best.-Nr.
Order no. **48907**



Betriebs-Nr. | Road no.: 503 269 [P]

D – In den Jahren 1939/40 entwickelten die Waggonfabriken Köln-Deutz und Uerdingen je einen vierachsigen Kesselwagen in Leichtbauweise. Vorangetrieben wurde die Entwicklung insbesondere durch das Militär, galt es doch für den Nachschub riesige Mengen an Rohöl und Treibstoffen zu transportieren. Um das vorhandene Stahlkontingent maximal zu nutzen wurde die Leichtbauweise, wie bei allen Kriegsbauarten, maximal ausgenutzt - wie sich bald herausstellte jedoch zu Lasten der Haltbarkeit. Beide Hersteller entwickelten nun Wagen mit selbsttragenden Kesseln. Während Deutz es bei Kopfstücken beließ, hatte die Uerdinger Bauart zusätzlich Langträger aus abgekanteten Profilen, die bei der Aufnahme der Längsdruckkräfte mitwirken sollten. Identisch waren die Hauptdaten der Varianten: die Länge über Puffer betrug 12,40 m, der Drehzapfenabstand 6,60 m und der Kessel fasste 63 m³.

EN – In 1939/40, the Köln-Deutz and Uerdingen wagon factories each constructed quadruple axle tank wagons in a lightweight design. The development was primarily driven by the military since it was necessary to transport enormous amounts of crude oil and fuels for replenishment purposes. As was the case with all war designs, the lightweight design was fully utilized in order to maximize the potential of the available steel quota. However, it soon became apparent that this was done to the detriment of the durability. At this point, both manufacturers were developing wagons with self-supporting tanks. Whilst Deutz left it at puffer beams, the Uerdinger design also boasted sole bars manufactured from bevelled profiles that were intended to contribute in absorbing longitudinal compression forces. The main data of both versions was identical: The length over buffers amounted to 12.40 m, the bogiepivot distance amounted to 6.60 m and the tank contained 63 m³.



Kesselwagen ZZ [P] "Dynamit Nobel" der DB
Tank Car ZZ [P] "Dynamit Nobel" DB



Best.-Nr.
Order no. **48914**



Betriebs-Nr. | Road no.: 564 098 [P]

Kesselwagen ZZ [P] "Homann" der DB
Tank Car ZZ [P] "Homann" DB



Best.-Nr.
Order no. **48919**



Betriebs-Nr. | Road no.: 525 348 [P]

Kesselwagen ZZ [P] "Eva" der DB
Tank Car ZZ [P] "Eva" DB



Best.-Nr.
Order no. **48936**



Betriebs-Nr. | Road no.: 540 717 [P]

Kesselwagen ZZ [P] "IVG" der DB
Tank Car ZZ [P] "IVG" DB



Best.-Nr.
Order no. **48937**



Betriebs-Nr. | Road no.: 5 533 023 [P]

Kesselwagen ZZ [P] "VTG" der DB
Tank Car ZZ [P] "VTG" DB



Best.-Nr.
Order no. **48938**



Betriebs-Nr. | Road no.: 591 453 [P]

Kesselwagen ZZ [P] "EVA" der DB
Tank Car ZZ [P] "EVA" DB



Best.-Nr.
Order no. **48939**



Betriebs-Nr. | Road no.: 539 314 [P]

Kesselwagen ZZ der DR
Tank Car ZZ DR



Best.-Nr.
Order no. **48940**



Betriebs-Nr. | Road no.: 52-43-42 [P]

Kesselwagen SCywf "Simotra" der SNCF
Tank Car SCywf "Simotra" SNCF



Best.-Nr.
Order no. **48943**



Betriebs-Nr. | Road no.: 588992 P

Kesselwagen ZZ [P] "Esso" der Brit-US-Zone
Tank Car ZZ [P] "Esso" Brit-US-Zone



Best.-Nr.
Order no. **48944**



Betriebs-Nr. | Road no.: 528 503 [P]

Kesselwagen ZZ [P] "BP" der DB
Tank Car ZZ [P] "BP" DB



Best.-Nr.
Order no. **48945**



Betriebs-Nr. | Road no.: 581 393 [P]

Kesselwagen SCywf "Adams" der SNCF
Tank Car SCywf "Adams" SNCF



Best.-Nr.
Order no. **48949**



Betriebs-Nr. | Road no.: 586 391 P

Kesselwagen ZZ [P] der SBB
Tank Car ZZ [P] SBB



Best.-Nr.
Order no. **49601**



Betriebs-Nr. | Road no.: 531 077 [P]

Kesselwagen ZZw der DR
Tank Car ZZw DR



Best.-Nr.
Order no. **48941**



Betriebs-Nr. | Road no.: 27 50 725 1221-1

Kesselwagen ZZ [P] "VTG" der ÖBB
Tank Car ZZ [P] "VTG" ÖBB



Best.-Nr.
Order no. **48946**



Betriebs-Nr. | Road no.: 21 81 005 6 659-3 [P]

Kesselwagen ZZ [P] "OEVA" der ÖBB
Tank Car ZZ [P] "OEVA" ÖBB



Best.-Nr.
Order no. **49600**



Betriebs-Nr. | Road no.: 33 81 785 1 420-8 [P]



KÜHLWAGEN TNF BERLIN "SEEFISCHE" DER DRG

REFRIGERATOR CAR TNF BERLIN "SEEFISCHE" DRG

VORBILDERECHTE WIEDERGABE DER
RAHMENKONSTRUKTION
PROTOTYPICAL REPRODUCTION OF THE FRAME

SENKRECHTE VERBREITERUNG UND
DIAGONALSTREBEN
VERTICAL BOARDING AND DIAGONAL BRACES



Best.-Nr. 47600
Order no.

Betriebs-Nr. | Road no.: 9576



KÜHLWAGEN IBDLPS 383 "TUCHER SICHER" DER DB

REFRIGERATOR CAR IBDLPS 383 "TUCHER SICHER" DB

AUSSEN UND INNEN
PROFILIERTE METALLRÄDER
METAL WHEELSETS WITH OUTSIDE AND
INSIDE CONTOURS

WAAGRECHTE VERBREITERUNG
HORIZONTAL BOARDING



Best.-Nr. 47605
Order no.

Betriebs-Nr. | Road no.: 16 80 802 4 968-8 [P]



Alle Abb. zeigen Handmuster | All pictures show layout versions

D – Als vereinfachte Kühlwagenbauart entstanden 1942 die Tnf Berlin (Tnfs38). Die Grundkonstruktion lieferte der bereits zuvor entwickelte Glmhs Dresden, in geschweißter Ausführung. Im Unterschied zu diesen, erhielten die Kühlwagen eine 300mm starke Isolierung und Innenauskleidung mit Zinkblech, um die Holzauskleidung im Inneren gegen Feuchtigkeitseintritt zu schützen. Damit die Türen dicht abschlossen, wichen die Schiebtüren zweiflügeligen Drehtüren. Das Markanteste war jedoch die senkrechte Verbreiterung in Verbindung mit dem typisch weißen Anstrich der Kühlwagen. Die Bundesbahn (DB) unterzog an den von ihr übernommenen Wagen, ab Mitte der 1950er, mehrere Bauartänderungen und Modernisierungen. So tauschte man die wartungsintensiven Radsätze mit Gleitlagern gegen moderne mit Rollenlagerung oder baute die Wagenkästen bei unzureichenden Isolierwerten gleich neu auf. Die Wagen behielten dadurch zwar ihre Hauptabmessungen, jedoch verschwand das auffällige Kastengerippe nun unter einer waagerechten Bretterverkleidung, später sogar unter Schichtholzplatten. Neuentwicklungen von Kühlwagen bei der DB ermöglicht es später privaten Brauereien eine Vielzahl an Wagen von der DB zu erwerben und für den Transport ihres Bieres zu nutzen. Da es sich dabei um Privatwagen der einzelnen Brauanstalten handelte, wurden diese zumeist mit der firmeneigenen Werbung versehen.

EN – In 1942, Tnf Berlin (Tnfs38) came into being as a simplified refrigerator car. The basic design was provided by the Glmhs Dresden, as a welded version. In contrast to these, the refrigerator cars were given 300 mm thick insulation and zinc plate inner lining in order to protect the internal wood cladding against moisture penetration. In order to ensure that the doors sealed completely, the double-leaf revolving doors were replaced with sliding doors. However, the most significant change was the vertical panelling combined with the typical white paint of the refrigerator cars. From the mid-1950s onwards, the German Federal Railway (DB) carried out several design modifications and modernisation work on the coaches it had acquired. The maintenance-intensive wheelsets with slide bearings were replaced with roller bearings; car bodies were rebuilt with the same design if their insulating properties were inadequate. As a result, the coaches retained their main dimensions; however, the eye-catching car body frame was now hidden under horizontal panelling, and later even under laminated wood panelling. New refrigerator car developments at DB made it possible for private breweries to purchase a variety of cars from DB and use them for transporting their beer. Since these were private cars belonging to specific breweries, in most cases they were decorated with the company's own advertising.



Kühlwagen Tnfs 38 "Seefische" der DB
Refrigerator Car Tnfs 38 "Seefische" DB



Best.-Nr. 47601
Order no.

Betriebs-Nr. | Road no.: 304 689

Senkrechte Verbreiterung und Diagonalstreben | Vertical boarding and diagonal braces

Kühlwagen Tnfs "Seefische" der DR
Refrigerator Car Tnfs "Seefische" DR



Best.-Nr. 47609
Order no.

Betriebs-Nr. | Road no.: 18-31-66

Senkrechte Verbreiterung und Diagonalstreben | Vertical boarding and diagonal braces

Kühlwagen Tnfs 38 "Hameico" der DB
Refrigerator Car Tnfs 38 "Hameico" DB



Best.-Nr. 47610
Order no.

Betriebs-Nr. | Road no.: 564 208 [P]

Waagrechte Verbreiterung | Horizontal boarding

Kühlwagen Ibdlps 383 "Holsten-Edel" der DB
Refrigerator Car Ibdlps 383 "Holsten-Edel" DB



Best.-Nr. 47603
Order no.

Betriebs-Nr. | Road no.: 23 80 805 0 001-6 [P]

Plattenwände | Plate walls

Kühlwagen Ibdlps 383 "Fürstenberg" der DB
Refrigerator Car Ibdlps 383 "Fürstenberg" DB



Best.-Nr. 47606
Order no.

Betriebs-Nr. | Road no.: 21 80 082 0515-3 [P]

Waagrechte Verbreiterung | Horizontal boarding

Kühlwagen Ibs 394 "INTERFRIGO" der DB
Refrigerator Car Ibs 394 "INTERFRIGO" DB



Best.-Nr. 47608
Order no.

Betriebs-Nr. | Road no.: 11 80 805 0 193-5

Plattenwände; Stirnseitige Eisluken, Aufstiege und Flettnerlüt-ter | Plate walls; With front ice hatches, steps and Flettner fans



GEDECKTER GÜTERWAGEN GLTRHS 23 "MAN" DER DB

COVERED FREIGHT CAR GLTRHS 23 "MAN" DB

EXTRA ANGESETZTE BREMSANLAGE,
FEDERPAKETE, RADLAGER UND TRITTSSTUFEN
EXTRA MOUNTED BRAKE SYSTEM AND BRAKE SWITCH,
SPRINGS, WHEEL BEARING AND STEPS

GEPRÄGTE AUSTAUSCHBAU
ACHSHALTER AUS METALL
STAMPED AXLE HOLDERS MADE OF METAL

KURZKUPPLUNGSKINEMATIK
SHORT COUPLING KINEMATICS



Best.-Nr. **48718**
Order no.

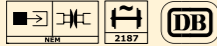

Betriebs-Nr. | Road no.: 195 058

Gedeckter Güterwagen Gltr "Carl Zeiss Jena" der DRG
Covered Freight Car Gltr "Carl Zeiss Jena" DRG



Best.-Nr. **48725**
Order no.



Betriebs-Nr. | Road no.: 83 345

Gedeckter Güterwagen Glr der DRG
Covered Freight Car Glr DRG



Best.-Nr. **48728**
Order no.

Betriebs-Nr. | Road no.: 80 244

Gedeckter Güterwagen Glr "Melitta" der DRG
Covered Freight Car Glr "Melitta" DRG



Best.-Nr. **48741**
Order no.

Betriebs-Nr. | Road no.: 80 695

Gedeckter Güterwagen Glr 22 "Zwilling" der DB
Covered Freight Car Glr 22 "Zwilling" DB



Best.-Nr. **48719**
Order no.



Betriebs-Nr. | Road no.: 192 144

Gedeckter Güterwagen Glr 22 "Telefunken" der DB
Covered Freight Car Glr 22 "Telefunken" DB



Best.-Nr. **48720**
Order no.

Betriebs-Nr. | Road no.: 190 107

Gedeckter Güterwagen Gltr 23 der DB
Covered Freight Car Gltr 23 DB



Best.-Nr. **48729**
Order no.

Betriebs-Nr. | Road no.: 195 173

Gedeckter Güterwagen Glr 22 "Knorr" der DB
Covered Freight Car Glr 22 "Knorr" DB



Best.-Nr. **48731**
Order no.

Betriebs-Nr. | Road no.: 190 662

Gedeckter Güterwagen Glr 22 "Brandt" der DB
Covered Freight Car Glr 22 "Brandt" DB



Best.-Nr. **48732**
Order no.

Betriebs-Nr. | Road no.: 191 110

Gedeckter Güterwagen Gltr 23 "Eicher" der DB
Covered Freight Car Gltr 23 "Eicher" DB



Best.-Nr. **48733**
Order no.

Betriebs-Nr. | Road no.: 195 032

Gedeckter Güterwagen Gltr 23 "Holder" der DB
Covered Freight Car Gltr 23 "Holder" DB



Best.-Nr. **48734**
Order no.

Betriebs-Nr. | Road no.: 195 495

Gedeckter Güterwagen Glr 22 "Liebherr" der DB
Covered Freight Car Glr 22 "Liebherr" DB



Best.-Nr. **48737**
Order no.

Betriebs-Nr. | Road no.: 190 879

Gedeckter Güterwagen Gltr 23 "Zündapp" der DB
Covered Freight Car Gltr 23 "Zündapp" DB



Best.-Nr. **48738**
Order no.

Betriebs-Nr. | Road no.: 195 291

Gedeckter Güterwagen Kuw der CFL
Covered Freight Car Kuw CFL



Best.-Nr. **48721**
Order no.

Betriebs-Nr. | Road no.: 23331

Gedeckter Güterwagen (Ghtuw) Glthu der DR
Covered Freight Car (Ghtuw) Glthu DR



Best.-Nr. **48730**
Order no.

Betriebs-Nr. | Road no.: 21 50 208 5257-4

Gedeckter Güterwagen Hbcs der SNCF
Covered Freight Car Hbcs SNCF



Best.-Nr. **48723**
Order no.

Betriebs-Nr. | Road no.: 21 87 212 4 103-0

Gedeckter Güterwagen Hbcs-w der ÖBB
Covered Freight Car Hbcs-w ÖBB



Best.-Nr. **48722**
Order no.

Betriebs-Nr. | Road no.: 21 81 213 2 105-1

Gedeckter Güterwagen Hbcs-w "Alma Käse" der ÖBB
Covered Freight Car Hbcs-w "Alma Käse" ÖBB



Best.-Nr. **48724**
Order no.

Betriebs-Nr. | Road no.: 20 81 013 5 101-2

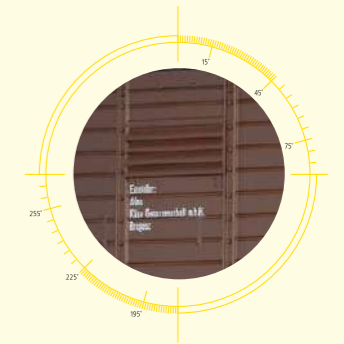



GEDECKTER GÜTERWAGEN GKLM "HENNIEZ MINERALWASSER" DER SBB

COVERED FREIGHT CAR GKLM "HENNIEZ MINERALWASSER" SBB

ANGESETZTE GRIFFFSTANGEN UND TRITTSUFEN
EXTRA MOUNTED STEPS AND HANDRAILS

KENNZEICHNUNG G-P-BREMSE INTERNATIONAL
IDENTIFICATION G-P-BREMSE INTERNATIONAL



Best.-Nr. 47871
Order no.

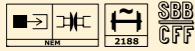

Betriebs-Nr. | Road no.: 20 85 114 4 214-6



Gedekter Güterwagen Gklm "Appenzeller Käse" der SBB
Covered Freight Car Gklm "Appenzeller Käse" SBB



Best.-Nr. 47860
Order no.



Betriebs-Nr. | Road no.: 20 85 111 8101-7



Gedekter Güterwagen Gklm "Aproz" der SBB
Covered Freight Car Gklm "Aproz" SBB



Best.-Nr. 47861
Order no.



Betriebs-Nr. | Road no.: 20 85 111 8765-9



Gedekter Güterwagen Gw der Brit-US-Zone
Covered Freight Car Gw Brit-US-Zone



Best.-Nr. 48029
Order no.



Betriebs-Nr. | Road no.: 1701

Gedekter Güterwagen Gh 03 "Stollwerk" der DB
Covered Freight Car Gh 03 "Stollwerk" DB



Best.-Nr. 48661
Order no.



Betriebs-Nr. | Road no.: 101 229

Gedekter Güterwagen Gh 03 "Gubor Schokolade" der DB
Covered Freight Car Gh 03 "Gubor Schokolade" DB



Best.-Nr. 48663
Order no.



Betriebs-Nr. | Road no.: 546 278 [P]

Offener Güterwagen E 037 "EUROP" der DB
Open Freight Car E 037 "EUROP" DB



Best.-Nr. 48625
Order no.



Betriebs-Nr. | Road no.: 01 80 504 3 675-9

Gedekter Güterwagen K2 "Ricola" der SBB
Covered Freight Car K2 "Ricola" SBB



Best.-Nr. 47862
Order no.



Betriebs-Nr. | Road no.: 31 984



Gedekter Güterwagen K2 "Calanda" der SBB
Covered Freight Car K2 "Calanda" SBB



Best.-Nr. 47868
Order no.



Betriebs-Nr. | Road no.: 518 068 [P]



Gedekter Güterwagen K2 "Eichhof Bier" der SBB
Covered Freight Car K2 "Eichhof Bier" SBB



Best.-Nr. 47869
Order no.



Betriebs-Nr. | Road no.: 513 830 [P]



UNSER VORBILD IST DAS ORIGINAL
Spannende Informationen zu den Vorbildern unserer Modelle finden Sie unter www.brawa.de

OUR MODELS ARE BASED ON THE ORIGINALS
Find out exciting information about the originals of our models at www.brawa.de

Gedekter Güterwagen Ts-51 Kmmks der DB
Covered Freight Car Ts-51 Kmmks DB



Best.-Nr. 48627
Order no.



Betriebs-Nr. | Road no.: 362 133

Gedekter Güterwagen K2 der SBB
Covered Freight Car K2 SBB



Best.-Nr. 47870
Order no.



Betriebs-Nr. | Road no.: 35 433



Gedekter Güterwagen K2 "Biere du Cardinal" der SBB
Covered Freight Car K2 "Biere du Cardinal" SBB

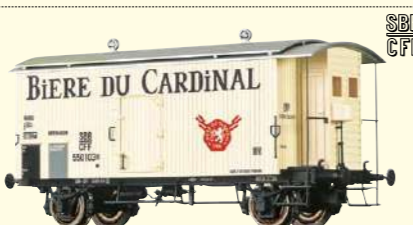

Best.-Nr. 47872
Order no.



Betriebs-Nr. | Road no.: 550 103 [P]



Gedekter Güterwagen K2 "Valsler" der SBB
Covered Freight Car K2 "Valsler" SBB



Best.-Nr. 47873
Order no.



Betriebs-Nr. | Road no.: 515 253 [P]



Kühlwagen Ibces "Interfrigo" der DB
Refrigerator Car Ibces "Interfrigo" DB



Best.-Nr. 48338
Order no.



Betriebs-Nr. | Road no.: 11 80 083 0 021-2 [P]

Kühlwagen UIC St 1 "Interfrigo" der NS
Refrigerator Car UIC St 1 "Interfrigo" NS



Best.-Nr. 48343
Order no.



Betriebs-Nr. | Road no.: 26 656



Kühlwagen Ibces "Interfrigo" der FS
Refrigerator Car Ibces "Interfrigo" FS



Best.-Nr. 48334
Order no.



Betriebs-Nr. | Road no.: 14 83 083 2 106-3



KESSELWAGEN Z [P] "BP" DER DRG

TANK CAR Z [P] "BP" DRG



RADSÄTZE IN SPITZENLAGERUNG
TIP BEARING WHEELSETS

EXTRA ANGESETZTER LAUFSTEG AM KESSEL
EXTRA WALKWAY ON THE BOILER

FEINE GRAVUREN UND NIETE
FINE ENGRAVINGS AND RIVETS

Best.-Nr. 47864
Order no.

Betriebs-Nr. | Road no.: 545 515 [P]

Kesselwagen Z [P] "Chemische Werke München" der K.Bay.Sts.B.
Tank Car Z [P] "Chemische Werke München" K.Bay.Sts.B.



Best.-Nr. 47866
Order no.

Betriebs-Nr. | Road no.: 502 230 [P]

Kesselwagen Z [P] "Bommerlunder" der DRG
Tank Car Z [P] "Bommerlunder" DRG



Best.-Nr. 47845
Order no.

Betriebs-Nr. | Road no.: 579 251 [P]

Kesselwagen Z [P] "Doornkaat" der DRG
Tank Car Z [P] "Doornkaat" DRG



Best.-Nr. 47846
Order no.

Betriebs-Nr. | Road no.: 579 256 [P]

Kesselwagen Z [P] "Antuka" der DRG
Tank Car Z [P] "Antuka" DRG



Best.-Nr. 47850
Order no.

Betriebs-Nr. | Road no.: 544 352 [P]

Kesselwagen Z [P] "Caltex" der DRG
Tank Car Z [P] "Caltex" DRG



Best.-Nr. 47865
Order no.

Betriebs-Nr. | Road no.: 539 688 [P]

WWW.BRAWA.DE



Alle Informationen wie z.B. LüP oder der Tauschradatz für Wechselstrom finden Sie auf unserer Website.

All information such as LüP or the exchange wheel set for AC can be found on our website.

NEUBAUKESSELWAGEN UIA

TANK CAR UIA

Kesselwagen Uahs "ERMEFER" der SNCF
Tank Car Uahs "ERMEFER" SNCF



Best.-Nr. 48771
Order no.

Betriebs-Nr. | Road no.: 33 87 784 9 947-9 [P]

Kesselwagen Uia "Avia Osterwalder" der NS
Tank Car Uia "Avia Osterwalder" NS



Best.-Nr. 48772
Order no.

Betriebs-Nr. | Road no.: 33 84 785 0 155-8 [P]

Kesselwagen Uia der GATX
Tank Car Uia GATX



Best.-Nr. 48773
Order no.

Betriebs-Nr. | Road no.: 33 80 795 6 698-4 [P]

Kesselwagen Zas "Wasserwagen" der Wiebe
Tank Car Zas "Wasserwagen" Wiebe



Best.-Nr. 48774
Order no.

Betriebs-Nr. | Road no.: 33 80 7856 311-5





ENTDECKEN SIE DIE BRAWA WEBSITE

DISCOVER THE BRAWA WEBSITE



BRAWA ONLINE MUSEUM TAUCHEN SIE EIN IN EINE FASZINIERENDE ZEITREISE

BRAWA ONLINE MUSEUM
MODEL RAILWAY HISTORY OF SPECIAL KIND



D – Sie suchen nach einem BRAWA Modell aus den vergangenen Jahren? Im BRAWA Online-Museum finden Sie eine umfangreiche Auswahl an Modellen, die heute nicht mehr ab Werk lieferbar sind. Wir wünschen Ihnen viel Spaß beim Entdecken unserer „historischen“ Modelle.

EN – At the BRAWA Museum you will find an extensive selection of locomotives, railcars, passenger coaches and freight cars, that are no longer available ex works. We wish you much fun while discovering our "historic" models.

WWW.BRAWA.DE/FANWELT/ONLINE-MUSEUM



FAQ – HÄUFIG GESTELLTE FRAGEN

FAQ – FREQUENTLY ASKED QUESTIONS



D – Damit Sie sich schnell und unkompliziert einen Überblick über unsere Themen verschaffen können, haben wir Ihnen hier oft gestellte Fragen mit den dazugehörigen Antworten zusammengefasst. Dieser Abschnitt wird regelmäßig um weitere FAQs ergänzt. Es lohnt sich daher, hier immer wieder vorbeizuschauen.

EN – That you can quickly and easily get an overview of our topics, we have summarized here frequently asked questions with the corresponding answers. This section will be regularly updated with more FAQs. It is therefore worthwhile to stop by here again and again.

WWW.BRAWA.DE/FAQ

WWW.BRAWA.DE



RUND UM DIE UHR INFORMIERT

IDEALLY CONNECTED AROUND THE CLOCK

AUSLIEFERUNG DELIVERIES

D – Sie möchten wissen, ob Ihr aktuelles Wunschmodell bereits im Fachhandel verfügbar ist? Dann besuchen Sie doch einfach unsere Website – wir berichten regelmäßig über die laufenden Auslieferungen an den Fachhandel.

EN – Would you like to know if your current desired model is already available in specialist shops? Then simply visit our website. We provide regular reports regarding current deliveries to specialist shops.

BEDIENUNGSANLEITUNG OPERATING MANUALS

D – Falls Sie die Bedienungsanleitung gerade nicht zur Hand haben sollten, können Sie anhand der Bestellnummer Ihres Modells die passende Ersatzteilliste über unsere Website als PDF-Datei herunterladen.

EN – If you do not have the spare part list to hand, you can download the respective spare part list from our website as a PDF file by using the order number of your model.

NEWSLETTER NEWSLETTER

D – Am schnellsten sind Sie informiert, wenn Sie den kostenlosen BRAWA E-Newsletter abonnieren. Er berichtet regelmäßig über das, was gerade bei BRAWA läuft – von neuen Produkten über aktuelle Veranstaltungen bis hin zu interessanten Werkstattberichten.

EN – The fastest way to receive information is to subscribe to our free BRAWA e-newsletter. It provides regular reports of the current happenings at BRAWA – from new products to current events and interesting workshop reports.



DIE ZEICHEN UND IHRE BEDEUTUNG

THE SYMBOLS AND THEIR MEANING

Epochenbezeichnung Era designation	Befahrbarer Mindestradius in mm Navigable minimum radius in mm	Lok besitzt Schwungmasse Locomotive has flywheel drive	Modell besitzt Federpuffer The model has spring buffers
Gleichstrom Analog Direct current Analog	Umschaltbar auf Oberleitungsbetrieb Can be switched over to overhead line operation	Zweilicht-Spitzensignal in Fahrrichtung wechselnd Double headlights alternating with the direction of travel	Tauschradatz für Wechselstrom (z. B. BRAWA Art.-Nr. 2180) Replacement wheel set for AC (e. g. BRAWA product code 2180)
Gleichstrom Analog BASIC Direct current Analog BASIC	Schnittstelle nach NEM 651 NEM 651 interface	Zweilicht-Spitzensignal und ein rotes Schlusslicht in Fahrrichtung wechselnd Double headlights and one red taillight alternating with the direction of travel	Wechselstromschleifer nachrüstbar (z. B. BRAWA Art.-Nr. 2220) AC pick-up can be retrofitted (e. g. BRAWA product code 2220)
Gleichstrom Analog BASIC+ Alternating current Analog BASIC+	Schnittstelle nach NEM 652 NEM 652 interface	Dreilicht-Spitzensignal in Fahrrichtung wechselnd Triple headlights alternating with the direction of travel	Sound eingebaut Integrated sound
Gleichstrom Digital Alternating current Digital	Schnittstelle mit Lötunkten Interface with soldering points	Dreilicht-Spitzensignal & zwei rote Schlusslichter in Fahrrichtung wechselnd Triple headlights and two red taillights alternating with the direction of travel	Für Sound vorbereitet Prepared for sound
Gleichstrom Digital EXTRA Alternating current Digital EXTRA	Schnittstelle Next18 Next 18 interface	Zwei rote Schlusslichter Two red taillights	Fahrzeug weitgehend aus Metall Vehicle predominantly in metal
Wechselstrom Digital Direct current Digital	Schnittstelle 21-polig 21-pole interface	Mit Innenbeleuchtung ausgestattet With interior lighting	Logo der Bahngesellschaft (Beispiel) Logo of the railway company (e. g.)
Wechselstrom Digital BASIC+ Direct current Digital BASIC+	Schnittstelle PluX22 PluX22 interface	Innenbeleuchtung nachrüstbar (z. B. BRAWA Art.-Nr. 2200) Interior lighting can be retrofitted (e. g. BRAWA product code 2200)	Digitale Kupplung Digital Coupling
Wechselstrom Digital EXTRA Direct current Digital EXTRA	Anzahl der Räder mit Haftreifen Number of wheels with friction tyres	Mit Inneneinrichtung ausgestattet With interior fittings	Funktionsfähiger, schaltbarer Lüfter Functional, switchable fan
Decoder Doehler & Haass	Lok besitzt Rauchgenerator Locomotive has a smoke generator	Modell besitzt Kupplungsaufnahme, jedoch keine Kurzkupplungskinematik The model has a coupler pocket but no short coupling cinematic	Energie Speicher Energy Storage
Länge über Puffer in mm Length over buffer in mm	Lok ist für den Einbau eines Rauchgenerators vorbereitet (z. B. Seuthe Nr. 20) Loco is prepared for the installation of a smoke generator (e. g. Seuthe No. 20)	Modell besitzt Kupplungsaufnahme und Kurzkupplungskinematik The model has a coupler pocket and short coupling cinematic	

Nach Redaktionsschluss dieses Katalogs können sich an den Produkten Änderungen ergeben. Konstruktions- oder Formänderungen, Abweichungen in Bedruckung und Farbton bleiben vorbehalten.
Products modifications are possible after this brochure is printed. Subject to modifications in design and shape. Colour deviations are possible.

Eingetragene Warenzeichen | Registered trademarks: Adams, Afri Cola, ALAK, Albani, Aldersbach, Alma Käse, Anker Brot, Appenzeller Käse, Aproz, ARAL, Avia, Avia Osterwalder, Bahlsen, BASF Trocken Eis, Bayer A.G., Berentzen, Biere du Cardinal, Valsler, Birkel, Bluna, Bommerlunder, Bombardier, BP, Brandt, Brasserie Meteor, Brouwerij de 3 Hoefuzers, Calanda Bräu, Caltex, Caramba Öl, Carl Zeiss Jena, Chemische Werke Hüls AG, Chemische Werke München, CSD, Dansk Svovlsyre OG, Danzas, DB, DB AG, DB Cargo, DEA, Dinkelacker, Doornkaat, Dortmunder Stifts-Bier, Doehler & Haass, DSB, DSG, Dynamit Nobel, Eicher, Eichhof Bier, Erdal, ERMEFER, Erstes Kulmbacher Aktienbier, Eschweiler Bergwerksverein Grube Anna, Esso, Esso D.D.P.A., Europ, Eva, Farbwerke Hoechst, Felix, Fischer Bräu, Fricke Texaco, Fritz Homann, FS, Fürstenberg, Grand Danois, Gatz, Gubor Schokolade, Gulf Oil, Hameico, Hansaplast, Hella, Henniez Mineralwasser, Holder, Holsten-Edel, Homann, Interfrigo, IVG, K+S Kali, Kaldewei, Knorr, Koninklijke Zwavelzuur Fabrieken, Krups, Kühne, Kulmbacher UNIMA Malzfabrik, Lambertz, Lambiotte Freres, Libella, Liebherr, Locataire Naptachimie, Luhns, MAN, Martha, Melitta, Merkur Transformatorenöl, Miele, Milkana, Mousel Bieres, Nieuwe Matex, Nivea, NS, OEVA, ÖBB, Ögussa, OROP, OZO Ipsa Rotkreuz, PAM, Patteux, Persil, Peugeot Talbot, PEZ, Post, Quarzwerke, Rail Cargo Austria, Rheingold, Ricola, SBB, Saint-Gobain, Simotra, SNCB, SNCF, staatsmijnen creosootolie, Stollwerk, Südzucker, Sunil, Tefal, Telefunken, Tuscher Sichen, TWINDEXX Vario®, UHU, Ultje, Union Siegel-Pils, UNOX, VEB Bitterfeld, VTG, Westfalen, Wick, WMF, Zentis, Zündapp, Zwilling

LIEBE ZUM DETAIL

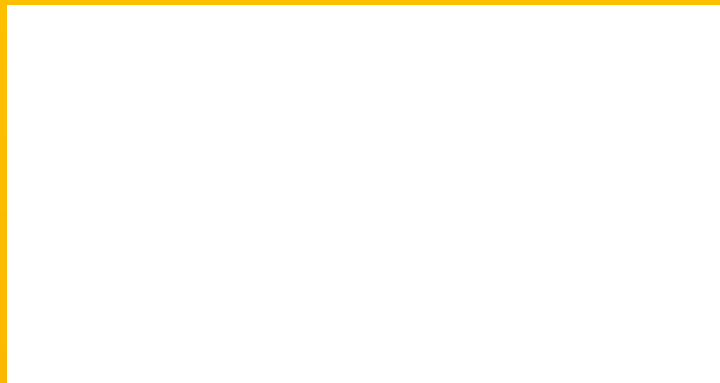

BRAWA Artur Braun Modellspielwarenfabrik GmbH & Co. KG

Uferstr. 24-30 | 73630 Remshalden

Hotline: Montag – Donnerstag, 13.00 – 15.00 Uhr | Telefon +49(0)7151 97935-68

Telefax +49(0)7151 74662 | info@brawa.de | www.brawa.de

