

B.T.S.

Better Than Scratch

Standard and Narrow Gauge Model
Railroad Kits and Details



Mainline, Shortline,
Industrial, Logging,
Mining, Residential
Kits and Details

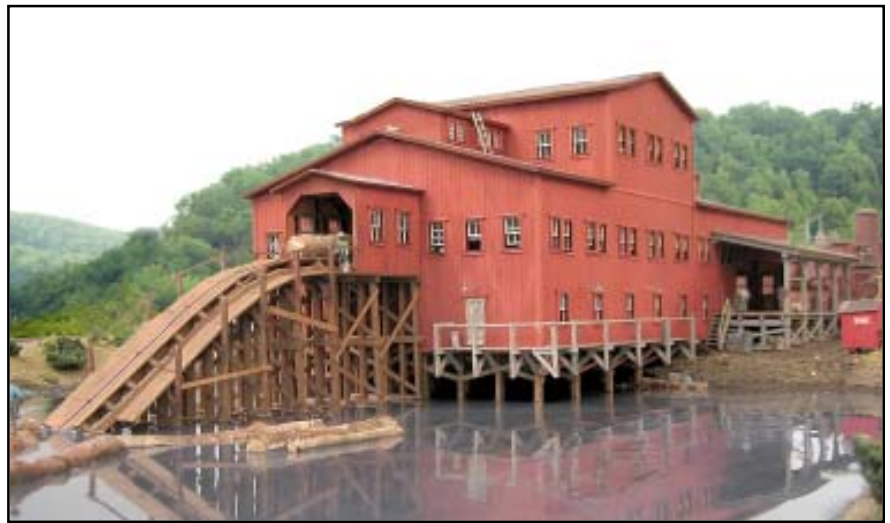

Catalog 2006

HO, S, TT, and O Scales

\$5.00

B.T.S.

Better Than Scratch

P. O. Box 856
Elkins, WV 26241
Phone: 304-637-4510
FAX: 304-637-4506
E-Mail: bill@btsrr.com

Contents

General Information	1
Structures	
McCabe Lumber Series	2
Recent Limited Edition Kits	18
Cabin Creek Coal Tipple	19
TT Scale Kits	20
Assorted Stations	21
East Broad Top	22
Waynesburg & Washington	24
Cabin Creek Series	25
Goin' Home Series	29
2nd Street Series	32
New River Series	33
General Yard Structures	36
ET&WNC Series	38
Best of the West	39
War Between the States Series	40
B.T.S. Car Shops	42
Details	
Posters and Signs	48
All Scale Modeling Materials	48
Figures	49
One-Niters	50
Shingles	52
Rolling Stock Details	53
S & O Scale Steam Locomotive Kits	56
S Scale Diesel Locomotive Kits	59
S Scale Greenbrier Railroad Models	60
Extra Detail Kits	61
Price List	Appendix

HO, S, TT, and O Scale Products are online!

Lots of color photos of our products
can be seen at our web site.

www.btsrr.com

Company History: *B.T.S.* was started in 1979 as Bill's Train Shop, a typical, walk-in model railroad hobby shop. In 1984, the operation was converted to mail-order. In 1991, the first craftsman kit with a *B.T.S.* label was offered to the S scale market, and later that year, *B.T.S.* became involved with laser-created kits using Master Creations as a subcontractor. *B.T.S.* expanded into O scale in 1996, HO in 1997, and in late 1997, *B.T.S.* purchased its own laser system. Kit development then went into high gear.

Master Creations (M-C) had been producing laser-created kits since 1984 and was the first to offer a fully laser-cut kit. Computerized, scripted sound effects, brass structure details, and many kit design innovations are among the 'firsts' that belong to *M-C*. Clear Creek Models, a line of HO₃ freight cars, was acquired by *M-C* and converted from cut styrene to laser-cut wood. In early 1998, *M-C* was acquired by *B.T.S.* and became a product line under the *B.T.S.* label.

Since the acquisition of *M-C*, *B.T.S.* has spent many hours converting the *M-C* AutoCad drawings to match the parameters of the *B.T.S.* lasers - faster lasers with much greater resolution, rewriting the kit instructions, upgrading the packaging, and simply getting the *M-C* line in stock and merged into the *B.T.S.* operation. Orders to distributors are usually turned around within a few days, and direct orders are often processed within 24 hours of receipt.

Product Lines: With the acquisition of *Master Creations*, we needed to determine how the *M-C* product lines would fit with our existing *B.T.S.* line.

Master Creations - Very Limited Edition Craftsman Structure Kits. These will be museum-quality, freelanced models that have the ultimate level of detail. Laser cut, naturally! Some may include room-sensitive lighting, and Silver Edition kits will include both lights and 24-hour scripted sound effects.

B.T.S. Structures - Usually these structures will be in production for several years; some may be limited editions. As in the case with the East Broad Top series, there may be several buildings offered for the same road. Most are laser-cut, but plaster and urethane is used where it works better.

B.T.S. Car Shops - Narrow and Standard Gauge Freight Cars in brass, urethane, and/or laser-cut wood. This product line also includes the Clear Creek HO₃ cars.

Design Criteria and Themes: Continuity is important to many model railroaders. The "Victorian-Gothic" look of many of the earlier *M-C* kits will continue on some future releases. In addition, other architectural philosophies will be featured.

There is one basic design requirement for all of our kits - it must be realistic. Even on the freelanced buildings, if there is a pipe, vent, or door added, there must be a valid reason for it being there. We will not just stick something on a building just to add character! While this is only toy trains, we want you to have the best possible realism in your fantasy world!

Subcontractors: All design and CAD work, laser cutting, sound generation, electronic assembly, and white metal casting is done by staff at *B.T.S.* Having full control over these functions insures quality and the lowest possible cost. In addition, we seek out the best in their fields for some subcontract work; our lost wax brass castings are made in Korea and China, and some urethane work is done by specialty companies here in the U.S.

Footprints: All dimensions specified in this catalog for kits are in scale feet and are approximations.

Product Numbering: With the merging of the *M-C* products into the *B.T.S.* line, all of the products were renumbered. In most cases, a prefix indicating scale (2=HO, 1=O, 0=S) was applied to the existing number; the last three digits of 99% of the products remained the same.

Payment Methods: *VISA, MasterCard, Discover and American Express* are accepted with your card number, signature, expiration date, V-code, and billing address. No charges are made to your account until just prior to shipping - except limited edition kits are charged when ordered. Check or money orders are accepted - Make these payable to *B.T.S.*

Shipments: All orders within the continental U.S. and Canada are shipped via U.S. Mail for a flat rate of \$5.00. Any other method of shipment requested, such as air shipments, Federal Express, etc., will be billed any additional amount over the flat rate. Foreign customers will have goods shipped by air unless a different means is requested; all foreign shipments are billed the actual shipping charges.

Customs: The actual amounts will be listed on the customs paperwork we are required by federal law to complete. Please do not ask us to falsify these documents. If there are specific codes we can use to help reduce the financial impact you face, please let us know at the time of the order.

Damaged Shipments: If a shipment is received in a damaged condition, please retain all packing materials and contact us for instructions. Failure to follow these two steps can result in a loss of claim with the shipper.

Hobby Shops: Check with our distributor: Wm. K. Walthers. We no longer sell directly to hobby shops.

Please note that due to limited appeal, some items shown in this catalog are available DIRECT ONLY from *B.T.S.* The high cost of creating short-run items would, when added to the normal dealer markup, result in product pricing that would be beyond reason. While we do not like to inconvenience our dealers, this is the only way that some products can be offered.

Guarantee: All products are guaranteed against defects in manufacture as determined by *B.T.S.* We will replace said items upon return of the defective part. This guarantee covers all non-electronic items. Electronic items are covered for one year from date of purchase. Returns are not available without authorization by *B.T.S.*

B.T.S. McCabe Lumber Co. Series



Sawmill Complex

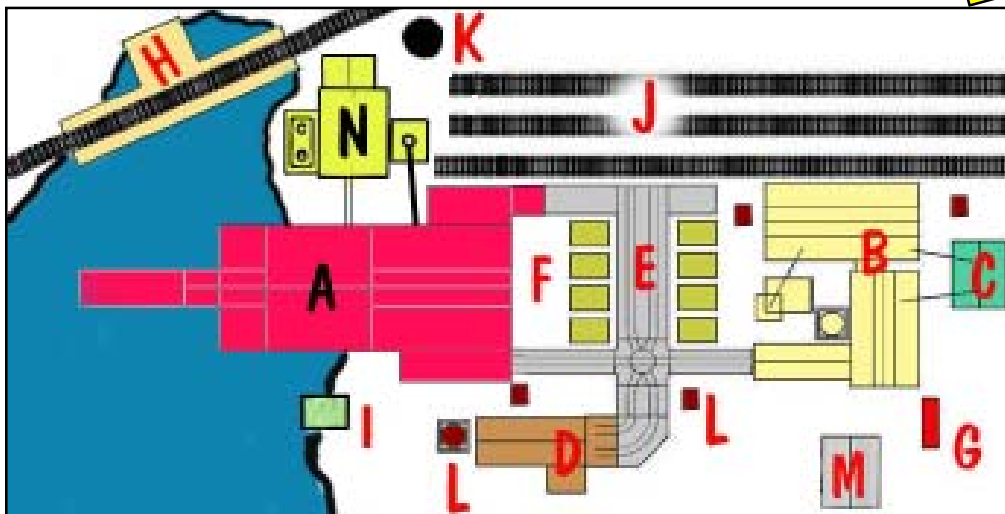

	<i>HO</i>	<i>S</i>	<i>O</i>
A - Slatyfork Sawmill	#28300	Coming	#18300
B - Planing Shed	#28225	Coming	Coming
C - Sawdust Shed	#28220	#08220	Coming
D - Drying Kiln	#28230	#08230	#18230
E - Tramway & Storage Yard	#28250	#08250	#18250
F - Drying Platforms	#28240	#08240	#18240
G - Boxcar Storage Shed	#27507	#07507	#17507
H - Log Dump	#28235	#08235	Coming
I - Pump House	#28245	Coming	Coming
J - Camp Cars, Set I, Five 40' Cars	#28265	Started	Started
Camp Cars, Set II, Three 66' Cars	#28270	Coming	In Stock
K - Slash Burner	Coming	Coming	Coming
L - Fire Hose Storage & Tank	#28260	#08260	#18260
M - Company Office	#28285	#08285	#18285
N - Power House	#28295	Coming	#18295

The kits listed above (except G) are Limited Editions and will not be rerun!

The McCabe Lumber Company

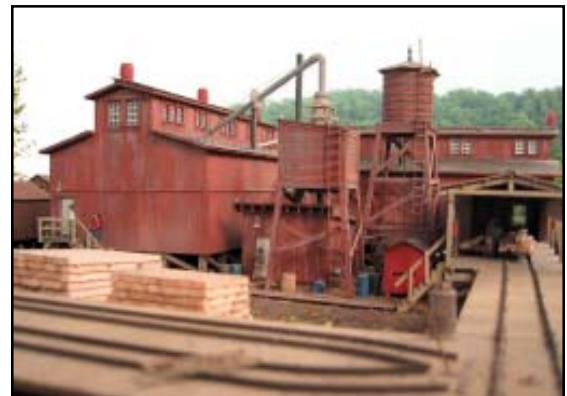
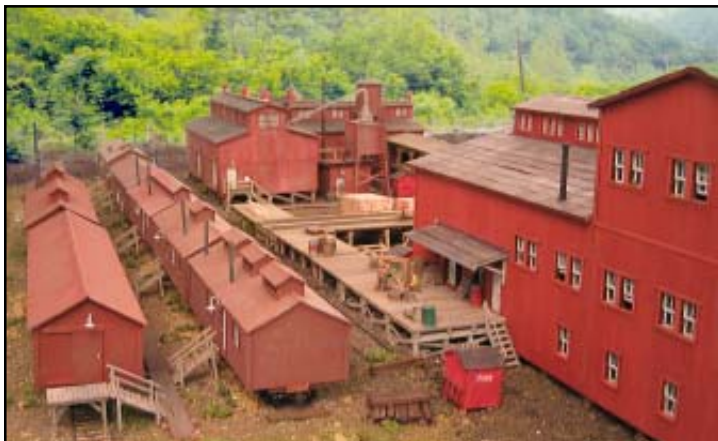
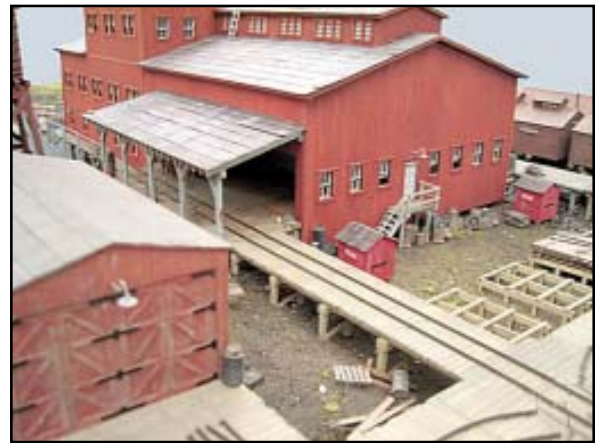
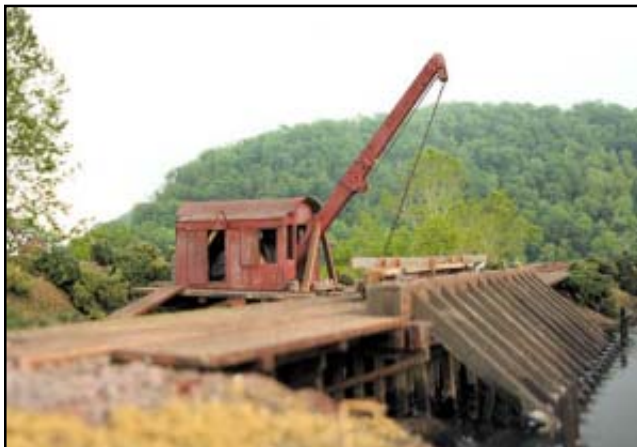
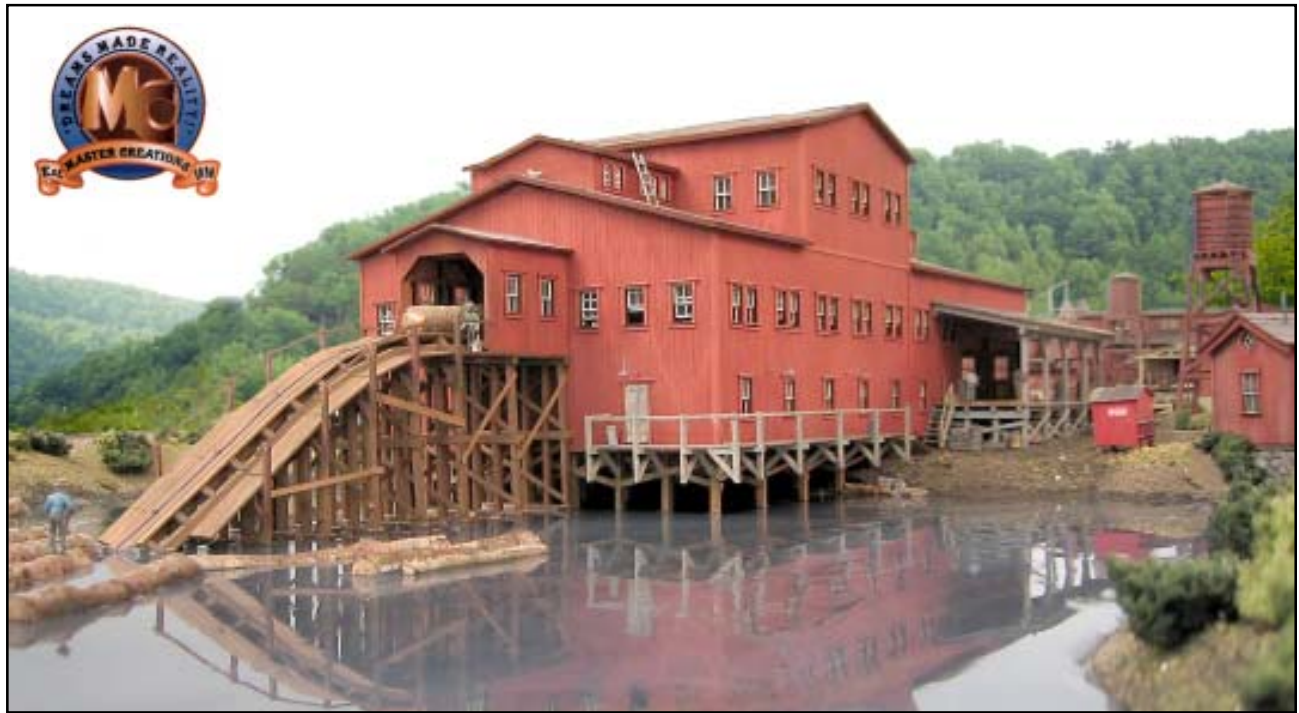

B.T.S. McCabe Lumber Co. Series



Slatyfork Sawmill

The McCabe Lumber Co. Slatyfork Sawmill was built in 1933 after the Coon Gap Sawmill burned to the ground. Slatyfork is a double bandsaw mill that can handle the load! This Master Creations' kit consists of laser-cut basswood, plywood, and detail castings. Interior walls and floors are included. And the standard features of **B.T.S.** kits are there...

positionable doors and window sashes, slot and tab construction, brass door knobs, and well-engineered construction providing fast and easy assembly.

HO Model Shown



We have designed this HO mill to use the Keystone Locomotive Works' excellent machinery. These components are not included in the kit, but the interior layout (below) showing these components will be included. The footprint is about 115' x 65'. Not shown in these photos are the 140+ brass and white metal detail castings in the HO kit! The sawmill is in stock now. Check our web site for more photos!

#28300 HO Scale
#18300 O Scale

Sold Direct Only

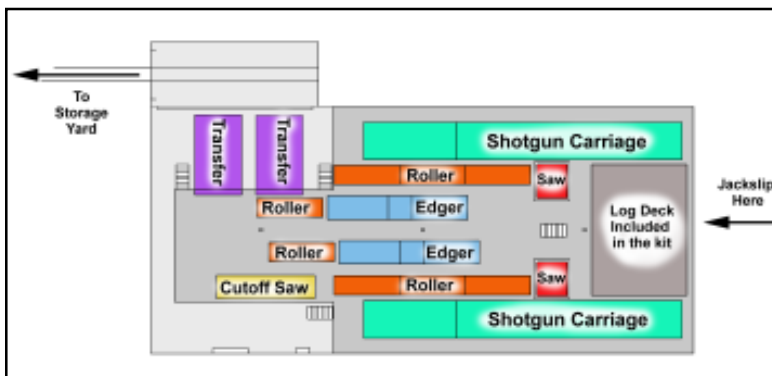

B.T.S. McCabe Lumber Co. Series



Scenes around the HO Complex!



B.T.S. McCabe Lumber Co. Series



McCabe Lumber Co. Planing Shed

The McCabe Lumber Co. has a Planing Shed; but it should be called a planing mill complex since it is now more than just a simple shed. The first version built by McCabe prior to the big fire was in fact just a simple shed, but no matter how big the operation has grown, the name still sticks!

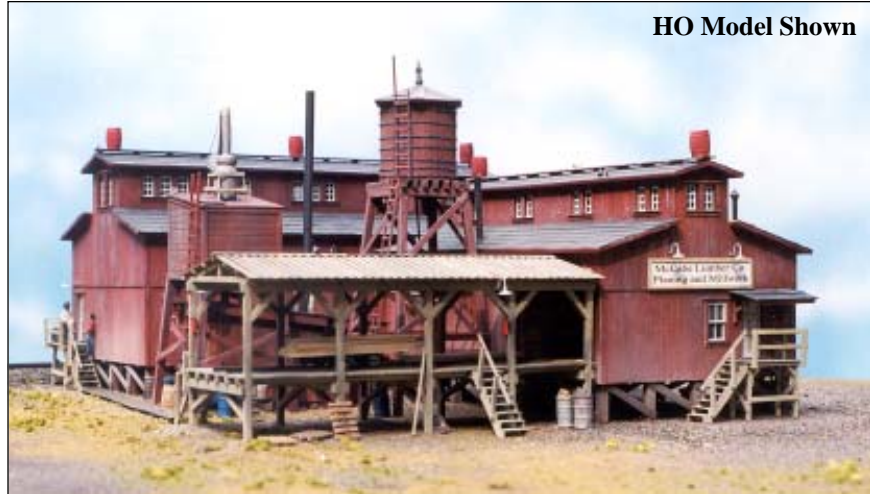

HO Model Shown

The planing complex consists of the transfer shed, two planing buildings, boiler house, water tank, and loads of neat, realistic details! The McCabe Sawdust Shed is a perfect compliment to the Planing Shed. The Tramway & Storage Yard kit connects to the transfer shed.

This kit consists of laser-cut basswood, plywood, and cardstock, tarpaper roofing, nearly 100 brass and white-metal detail castings, and loads of character. The tabbed, well-engineered construction provides fast and easy assembly. The footprint is about 70' x 90'.



Kit includes all details shown except the track, ground cover, and background. More photos are on our web site at www.btsrr.com

#28225 HO Scale

Sold Direct Only

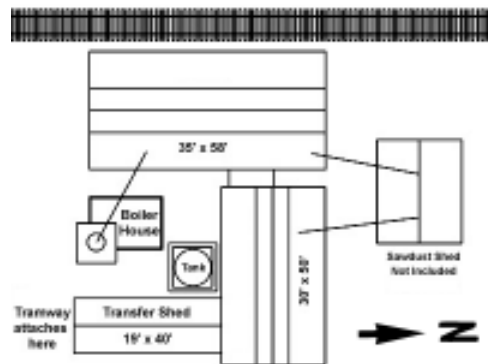

B.T.S. McCabe Lumber Co. Series



McCabe Power House

#28295 HO Scale
#18295 O Scale



At the Slatyfork Sawmill, the power house is the thing that makes everything work. The original boiler house was rebuilt after the 1933 fire and the addition was added to the back to house larger boilers. Steam from these two boilers power the steam engines in the mill, and provide heat to the kiln. In 1940, the dynamo house was added to the side of the boiler house and a small steam engine was installed to turn the dynamos and generate electrical power. Sawdust from the bandsaws becomes fuel for the boilers and is stored in the large bin until needed.

This Master Creations' kit consists of laser-cut basswood, plywood, cardstock and 50+ detail castings. Interior walls and floors are included, as are several power poles and the large power junction behind the dynamo house. And the standard features of **B.T.S.** kits are there... positionable doors and window sashes, slot and tab construction, peel & stick window sashes, brass door knobs, removable roofs, and well-engineered construction providing fast and easy assembly. Boilers are not included, but if enough folks want them, perhaps a short run can be made; let us know!



**Sold
Direct Only**

Note - Only a few of the castings are shown in the photos. Castings include workers, pigeons, barrels, crates, drums, and the always needed basic junk! Sawmill not included!!

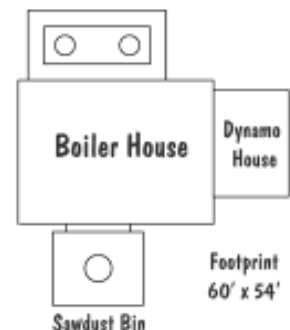

B.T.S. McCabe Lumber Co. Series



Tramway & Storage Yard

The McCabe Lumber Co. Tramway connects the sawmill to the storage yard, drying kiln, and planing shed. It is a key feature of the complex. In this kit are the eight drying platforms, cart turntable, single and double track tramways, two carts, and the loading docks. As the lumber is cut in the sawmill, it is stacked on four-wheel carts and pushed out on the tramway to the storage yard. There it is stacked on platforms and allowed to air dry. Layers of lumber are separated by thin boards to allow the air to circulate. At the McCabe facility, the loading dock for boxcars is part of the tramway.

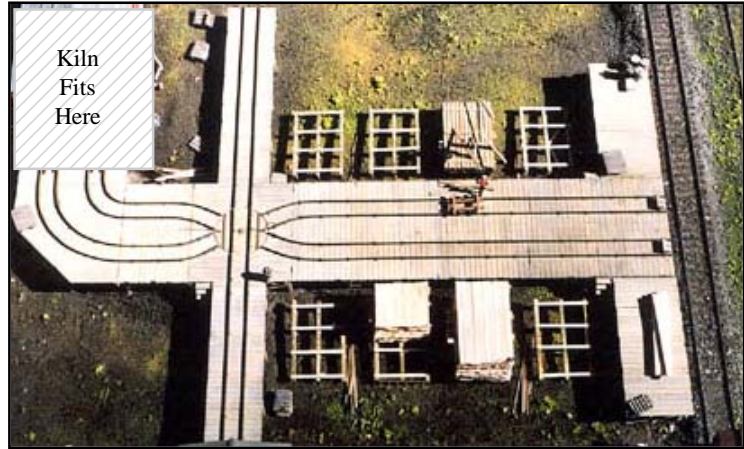

This kit consists of laser-cut basswood, plywood, detail castings, and a very complex appearance. However, the well-engineered construction provides fast and easy assembly. Weathered rail and spikes are part of this kit, as are the laser-cut spike holes! And in the box are hundreds of pieces of pre-cut lumber for stacking in the yard. If the Drying Kiln is to be included in your complex, it will be easier to build the kiln and the tramway at the same time. The footprint is about 100' x 110'. And because of our engineering, it can be assembled in one of several different positions to better fit your layout. HO model is shown; some details may vary between scales.

- | | | |
|--------|-------------------------------|----------|
| #18250 | McCabe Tramway & Storage Yard | O Scale |
| #28250 | McCabe Tramway & Storage Yard | HO Scale |
| #08250 | McCabe Tramway & Storage Yard | S Scale |

In case the basic kit is not large enough to handle your specific needs, there are two add-on kits. The first add-on contains four additional drying platforms, more detail castings, and more pre-cut lumber.

- | | | |
|--------|-------------------------|----------|
| #18240 | McCabe Drying Platforms | O Scale |
| #28240 | McCabe Drying Platforms | HO Scale |
| #08240 | McCabe Drying Platforms | S Scale |



And if you need additional tramway, the second add-on kit includes approximately scale 35' of single track tramway and scale 40' of double-track tramway.

- | | | |
|--------|--------------------------|----------|
| #18240 | McCabe Tramway Extension | O Scale |
| #28255 | McCabe Tramway Extension | HO Scale |
| #08255 | McCabe Tramway Extension | S Scale |



Two or more complete Tramway & Storage Yard kits can be combined as was done here photographically on the right.

Other layouts can be done to better fit your specific area.



B.T.S. McCabe Lumber Co. Series



Whether you have the Coon Gap Sawmill or the Slatyfork Sawmill, the McCabe series structures work with either one. These will be laser-cut kits, and feature the level of detail and quality you have come to expect from **B.T.S.** These structures will be offered in HO scale first, and if there is sufficient demand, S and O scale versions will follow. All kits will be limited editions.

Sawdust Shed

#08220 S Scale
#28220 HO Scale

**Sold
Direct Only**

At the sawmill, fine sawdust is created by the bandsaw blade, and lots of sawdust is created by the planers and other tools in the planing shed. That sawdust is stored in this shed until it is sold.

This kit consists of laser-cut basswood, plywood, and cardstock, tarpaper roofing, detail castings, and loads of character. The tabbed, well-engineered construction provides fast and easy assembly. The footprint is about 23' x 28'. Some details vary between scales.



Sawdust Shed - HO Version



Logging Wagon in HO

This HO Logging Wagon is a fully-assembled brass model made for us in Korea. Easy to paint as most of the parts of the prototype were wood. You will need two or three for any lumber operation, or just one for the back alley in any town.

#28504 HO Scale

Drying Kiln

The McCabe Lumber Co. now has a Drying Kiln. In the kiln, steam heat is piped through radiators generating a lot of dry heat that will dry out the lumber faster than air drying. Cartloads of lumber are rolled into the kiln, the doors closed and heat applied.

This kit consists of laser-cut basswood, plywood, and cardstock, tarpaper roofing, detail castings, and a very complex appearance. The tabbed, well-engineered construction provides fast and easy assembly.



The footprint is about 33' x 50' including 13' of deck on the front to join to the tramway. If the Tramway is to be included in your complex, it will be easier to build the kiln and the tramway at the same time. HO model shown; some details may vary between scales.

#18230 O Scale
#28230 HO Scale
#08230 S Scale

**Sold
Direct Only**

B.T.S. McCabe Lumber Co. Series



Pump House

One item critical for the operation and survival of the sawmill complex is water. Water is pumped from the mill pond or river into storage tanks around the complex where it feeds the various boilers. This is the job of the pump house. The pumps, and the engines to drive them, are located in this house.

The pump house at the McCabe Lumber Co. seems to be the collection point for many pieces of junk and clutter including the 1876 Challenger Pump that has been removed from service. A pipe rack stands along a side of the pump house to hold the various leftover pieces of pipe. A floating dock stands beside the pump house in the mill pond in case there is work to do on the inlet pipes.

This kit consists of laser-cut basswood, plywood, and cardstock, tarpaper roofing, stone foundation, and over a dozen white metal and brass detail castings. The tabbed, well-engineered construction provides fast and easy assembly. The kit can be built as shown on the stone foundation, or on flatland with a timber foundation.

The footprint is about 24' x 28'. The HO model is shown; some details will vary between scales.

#28245 HO Scale

**Sold
Direct Only**



Log Dump

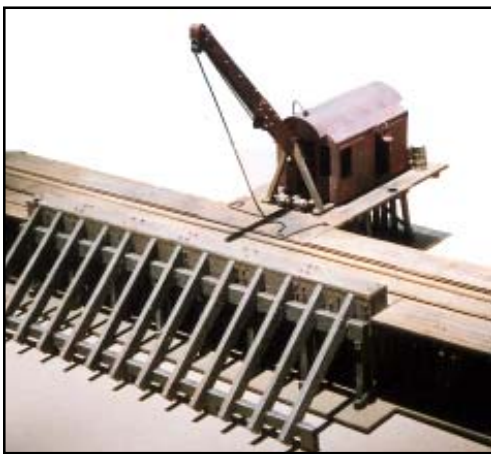

**Sold
Direct Only**

Fresh-cut logs are unloaded into the mill pond by leverage. Chains are run under the logs and connected to the large beam at the top of the slope. When the cable is pulled up by the hoist, the logs are flipped off the car into the pond.

John McCabe located an old Barnhart loader, got a new electric hoist, and cobbled them together to form the power for the dump. A common trestle was run out along the edge of the mill pond, and sloping beams were added to help ease the logs into the pond.

This kit consists of laser-cut basswood, plywood, and cardstock, corrugated roofing, and detail castings. The kit includes all the ties needed, but does not include the rail. It can be built as standard gauge, dual gauge, or narrow gauge. The footprint is about 110' x 55' and the length of the trestle can be reduced if space is short. The HO model is shown; some details may vary between scales.

Not all details are shown in the photos. When installed on the layout, there will be walkways to solid ground and cables running back to stumps to help hold the loader in place.

#28235 HO Scale

#08235 S Scale



B.T.S. McCabe Lumber Co. Series



Fire Hose Storage & Water Tank



Fire is the worst thing that can happen to a sawmill. And sadly, history shows that it happened often! With all that wood stacked around, sparks from the boiler house or a steam loco can get things going.

Since the first McCabe sawmill was lost to a fire, John McCabe decided to reduce the risk. A 38-foot high water tower was built strictly for the purpose of holding water just in case of fire. And six fire hose storage sheds were placed around the yard providing quick and easy access to fire hoses. Water was supplied to the sheds via underground pipes.

This kit consists of laser-cut basswood, plywood, and cardstock, tarpaper roofing, and white metal and brass detail castings. The tabbed, well-engineered construction provides fast and easy assembly. **Six hose storage sheds and one water tank are included.**



Use of these components is not restricted to the sawmill. They can be used around most other industries and in the rail yard. Footprint : Tank - 14' Sq. & Sheds - 6' x 7'

#28260 HO Scale #18260 O Scale #08260 S Scale

Sold Direct Only

Company Office

The McCabe Company Office is the location of the sales reps, purchasing agents, accountants, clerks, and the office of John T. McCabe. It can be located right on the sawmill property or on main street in town.

This kit consists of laser-cut basswood, plywood, self-adhesive shingles, and detail castings. Interior walls and floors are included. And the standard features of B.T.S. kits are there... positionable doors and window sashes, slot and tab construction, and well-engineered construction providing fast and easy assembly. The footprint is about 18' x 36'.

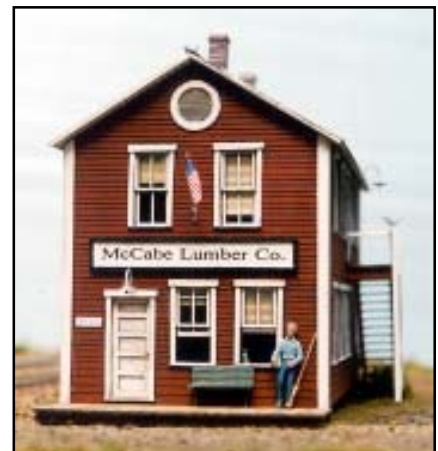

#08285 S Scale
#18285 O Scale
#28285 HO Scale

Sold Direct Only



B.T.S. McCabe Lumber Co. Series



COYOTE DRAW ENGINE HOUSE

Coyote Draw Engine House

This two-stall narrow gauge engine house is patterned after a second engine house built by the McCabe Lumber Company as their operations were expanded. It features laser-cut parts with full interior framing detail, positionable windows, removable roofs, side shop area, and true board-by-board appearance with less than half the work of traditional kits! It is sized to accept locomotives up to the Westside 3-truck Shay size. Kit #20776 provides junk and tools for detailing the interior of the HO model. Approx. Size - 29' x 60' w/ 20' x 20' Shop

#27445 HO Scale



MCCABE'S BACKWOODS ENGINE HOUSE

McCabe's Backwoods Engine House

This little engine house is the perfect backwoods narrow gauge engine house for any logging operation. It is designed to fit small Heisler, Climax and Shay locomotives. The removable roofs allow for full interior detailing. Kit #20776 provides junk and tools for detailing the interior of the HO model. Approx. Size - 18' x 50' w/ 20' x 18' Shop

#07450 S Scale

#27450 HO Scale



WEST SIDE CAMP REYNOLDS COOKHOUSE

Camp Reynolds Cook House

The Westside Lumber Co. had a permanent logging camp at Reynolds and at the center was a large cook house. Approx. Size - 50' x 36'

#27475 HO Scale



LOGGING BUNKHOUSES

Logging Bunkhouses

This kit builds **three** portable logging bunkhouses similar to the style used by the Westside Lumber Co. They have removable roofs and are interior ready. Kit #20777 provides details for the interior of these bunkhouses in HO scale. Approx. Size - 22' x 13'

#07425 S Scale

#17425 O Scale

#27425 HO Scale

B.T.S. McCabe Lumber Co. Series



MoW Speeder

Standard Gauge

The *B.T.S.* McCabe Lumber Co. MoW Speeder was built in the company shops. One day, the railroad superintendent realized that a larger speeder was needed for track maintenance and the order went out to the shop crew to get busy. An old boxcar body, a truck chassis, and some great planning on the part of the crew provided the main ingredients for a unique and handy speeder.

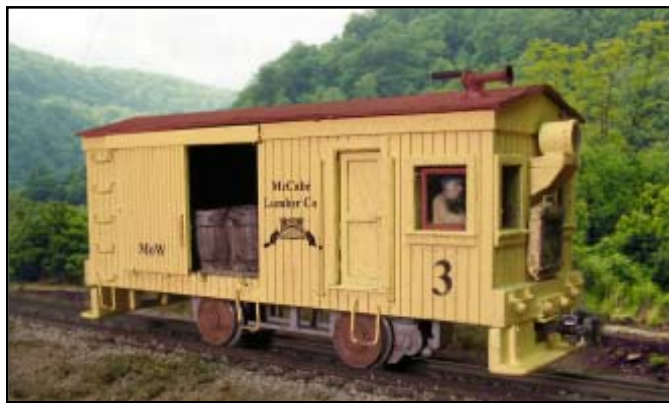

The body kit consists of laser-cut basswood, plywood, cardstock, and brass & white metal detail castings. The standard features of *B.T.S.* kits are there... positionable doors, slot and tab construction, brass door knobs, unique character, and well-engineered construction providing fast and easy assembly. And the driver, load, and decals are included!

The fully-assembled mechanism is American Made by David Hoffman! It features a sheet brass frame, lost-wax end beams and steps, NWSL gears and wheelsets. All are limited edition kits.

Narrow Gauge

#28280	HO Scale	In Stock
#28281	HOn3	In Stock
#08280	S Scale	
#08281	Sn3	
#08282	Sn2	In Stock
#08283	Sn42	In Stock
#18280	O Scale	
#18281	On3	In Stock
#18283	On30	In Stock



B.T.S. McCabe Lumber Co. Series



Bunk Car, Single Clerestory #29300



Bunk Car, Triple Clerestory #29301



Blacksmith Car

Sold Direct Only



Office Car



Shower Car



Camp Cars, Set I

The McCabe Lumber Co. would not be complete without a set of logging camp cars. Logging camps had to be portable so the loggers could have easy access to the timber. The facilities included bunk cars, dining and kitchen cars, shower cars, and the necessary office and blacksmith car. These kits are based upon the standard gauge Rayonier Lumber Co. prototypes.

These cars will look great on a spur in the woods or parked on a couple of tracks near the sawmill. Narrow gauge modelers can simply build the cars and place them beside the track on stacks of timbers.

HO Set I #28265 - includes a Bunk Car (Single Clerestory), Bunk Car (Triple Clerestory), Shower Car, Office Car, and Blacksmith Car. The set includes the ramps and walkways.

Kits are less trucks and couplers - the sample models use archbar trucks and Kadee couplers.

HO Set II #28270 - includes the Cookhouse Car and two Dining Cars (one for each side of the cookhouse car.) The set includes the ramps and walkways.

The following Individual Cars are also available:

- #29300 HO Scale McCabe Bunk Car, Single Clerestory
- #29301 HO Scale McCabe Bunk Car, Triple Clerestory
- #09300 S Scale McCabe Bunk Car, Single Clerestory
- #19300 O Scale McCabe Bunk Car, Single Clerestory
- #19301 O Scale McCabe Bunk Car, Triple Clerestory
- #19302 O Scale McCabe Blacksmith Car
- #19303 O Scale McCabe Office Car
- #19304 O Scale McCabe Shower Car

Back of the Bunk Cars



B.T.S. McCabe Lumber Co. Series



Camp Cars, Set II

Kits are less trucks and couplers - the sample models use archbar trucks and Kadee couplers.

The following Individual O Scale Cars are also available:

- #19306 O Scale McCabe Cookhouse
- #19307 O Scale McCabe Dining Car

Both sets consist of laser-cut basswood, plywood, and cardstock, corrugated roofing in the HO kits - tar paper in the S and O, and plastic, loads brass and white-metal detail castings. Positionable window sashes and doors are standard *B.T.S.* features. The tabbed, well-engineered construction provides fast and easy assembly. HO models shown; some details may vary between scales.



Above - Cookhouse

Below - Dining Car (Two per Set)



Stumps



Useful in all scales!



- #91106 Stumps, Sapling (3/16" Top Dia.) Pkg 18
- #91111 Stumps, Small (1/4" Top Dia.) Pkg 12
- #91112 Stumps, Medium (1/2" Top Dia.) Pkg 9
- #91113 Stumps, Large (3/4" Top Dia.) Pkg 6

HO Logging Details

- | | | |
|-------|---------------------|----------------|
| 20608 | Loggers Lube Can | Brass, Pkg (2) |
| 20610 | Broadax | Brass, Pkg (2) |
| 20611 | Saw Anvil | Pkg (2) |
| 20615 | Saw Swage | Brass, Pkg (5) |
| 20619 | Small Tong | Brass, Pkg (5) |
| 20625 | Large Tong | Brass, Pkg (4) |
| 20636 | Peavey | Brass, Pkg (2) |
| 20638 | Falling Ax | Brass, Pkg (2) |
| 20645 | Pickaroon | Brass, Pkg (2) |
| 20649 | Control Lever | Brass, Pkg (2) |
| 20655 | Large Band Wheel | Brass |
| 20657 | Bandsaw Drive Wheel | |
| 20658 | Knife Switch | Brass, Pkg (5) |
| 20659 | Headblock | Brass |
| 20673 | Claw Bar | Brass, Pkg (2) |

***B.T.S.* McCabe Lumber Co. Series**



Bell Crawler Model 36

Everyone needs several of these mechanical beasts. Offered with and without the blade, they are perfect as a load on the flatcar above, carving a road out of the woods, or hauling logs to the railroad.

The Model 36 features a cable-operated blade - in later years, hydraulics performed this function. It can be used in the woods, on a construction site, or as a flat car load

These freelanced model kits consists of high-quality, no-odor urethane castings with brass wire, NS mesh, decals, and a few other bits. Approx. size as shown - scale 20' long with a 10'-6" wide blade.



#18600 O Scale Bell Crawler, Model 36, w/ Blade

#18601 O Scale Bell Crawler, Model 36, w/o Blade (Shown at left)



Crawler Model 36 w/ Logging Arch

Everyone needs several of these mechanical beasts for their logging railroad. The logging arch was used for hauling logs to the rail line.

These freelanced model kits consists of high-quality, no-odor urethane castings with brass wire, NS mesh,

decals, and a few other bits. Approx. size as shown - scale 31' long with the arch just over 11 scale feet wide.

O Scale #18604 Bell Crawler, Model 36, w/ Logging Arch



Bell 39 Crawler

The Bell Crawler is a model that represents the typical crawler from the late 1930s onward. Everyone needs several of these mechanical beasts. The M-39 can be used in the woods, on a construction site, or as a load on a depressed-center flatcar such as *B.T.S.* #09209.



These freelanced model kits consists of high-quality, no-odor urethane castings with brass wire, decals, and a few other bits. Approx. size as shown - scale 18' long with a 11'-6" wide blade.

#08606 S Scale



**Sold
Direct Only**

Instrument House

Instrument houses can be seen along the railroad in many different locations and sizes. Used to house the various signaling components, they often became a storage spot for odds and ends including track components.

The kit features urethane castings for the instrument house, and includes all the details shown - the laser-cut pallet, steps, cable reel, and tie plates. Castings include pigeons, insulators, drums and barrel, and wood ties and power pole are in the box. Footprint of the instrument house is approximately scale 7' x 9'.

#05005 S Scale



**Sold
Direct Only**



Master Creations™

**Sold
Direct Only**

Recent Limited Edition Kits

We design our **Master Creations** limited run structure kits to be our most comprehensive and complete kits available. They are museum-quality dioramas in a box containing all buildings and details necessary to create a scene; you add the track, paint, and ground cover. Our limited edition kits are never rerun.

Our limited run kits feature many exclusive features not available from any other manufacturer, and we continually develop and implement new features with each succeeding kit! What we made last year is surpassed this year!

McCabe Planing Shed ➡

2001 Release HO



Cabin Creek Coal Tiptle ⤴

2000 Release HO - Sold Out, S and O Scales



Hyde Pulp Mill ⤴

1999 Release HO - Sold Out!

Donovan's Transfer Co. ⤴

1998 Release HO - Sold Out!

Elliott & Sons Supply ⤴

1999 Release HO & S 2001 Release O Scale

Slatyfork Sawmill ⤴

2003 Release HO



Limited Edition Kits are Never Rerun!



Our O Scale Cabin Creek Coal Tipple received the *Model Railroader* 2001 Reader's Choice Award for O Scale Structures. The S Scale version came in second for S Scale Structures.

Thanks for the votes!

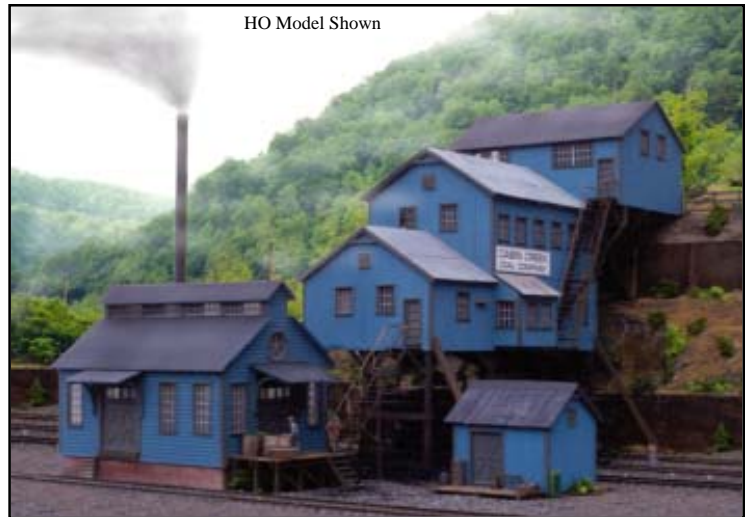

Coal! *Black Diamonds!*

Limited Edition Master Creations' Kit

Cabin Creek Coal Tipple

This fossil fuel has been an important element in the developments of the 19th and 20th centuries. From providing the heat to generate steam for industries, ships, and locomotives, to being a wonderful source of extracts for use in fabrics and medicines, coal does it all.

Since coal is not found everywhere, there must be an economical means of transportation. Railroads answered that need. And to provide short-term storage and to facilitate the easy loading of the rail cars, the tipple was developed. In addition, the tipple was a place for sorting coal into different sizes. Each track was provided with a different size coal.

The name 'tipple' is derived from the time when men would push carts full of coal to the wooden bunker and tip them over for dumping. Wood was used as the building material of choice until some time in the late 1920's when metal framing became faster and cheaper to use. Wood tipples lasted into the 1950's in some areas.

The Cabin Creek Coal Tipple is a freelanced composite of several different tipples located in West Virginia and Pennsylvania. Three tracks are serviced here. A power house, the place where a small steam engine generates electricity to run the machinery of the tipple, is provided as is a small storage shed. From the back of the headhouse at the top, a covered conveyor runs up the mountain side to the drift mine.

As with all our kits, the Cabin Creek Coal Tipple is laser cut and engineered for easy construction. Slots and tabs eliminate alignment problems. Adhesive-backed window sashes make glazing the windows a snap, and the adhesive-backed shingles make roofing application a breeze. Other features include positionable doors and window sashes, and positionable coal chutes. Naturally, an ample supply of brass and white metal castings are included to provide the ultimate level of detail. Details will vary between scales.

- | | |
|-----------------|--|
| #28105-L | Cabin Creek Coal Tipple, HO, Lighted
No more than 350 HO scale kits total will be made! Sold Out!! |
| #08105-L | Cabin Creek Coal Tipple, S Scale, Lighted
No more than 75 S scale kits total will be made! In Stock Now! |
| #18105-L | Cabin Creek Coal Tipple, O Scale, Lighted
No more than 90 O scale kits total will be made! In Stock Now! |

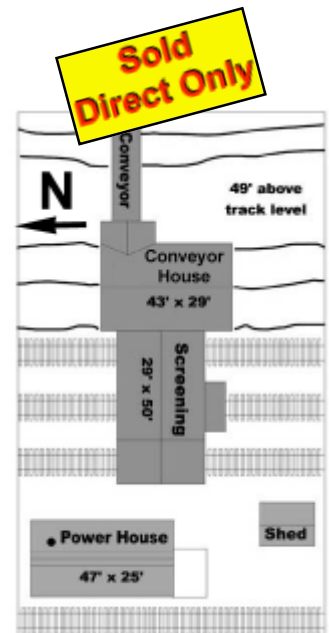



TT Scale? Why Not!

For years, the folks modeling 1/10" have been watching other scales get new and improved products. Now, they also have laser-cut kits! Same great features and details of our HO line, just a little bit smaller. Other kits will be added to the line as time permits.



#37400 TT Scale

Flagstop Station

The perfect small town or wayside station for your pike! This depot is based on a southern prototype, but it is generic enough for nearly any location.

Basswood and cardstock components are laser-cut. Adhesive-back shingles and window sashes. Positionable doors and window sashes. Approx. Platform Size - 38' x 19'

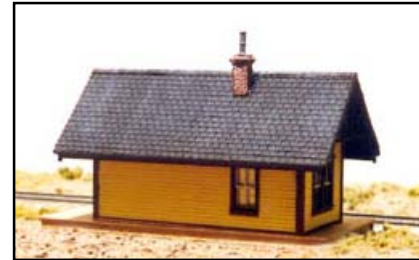

Loading Dock

Ready for the team track! Either ramp can be left off for variety. Approx. Size - 16' x 78'

#37506 TT Scale

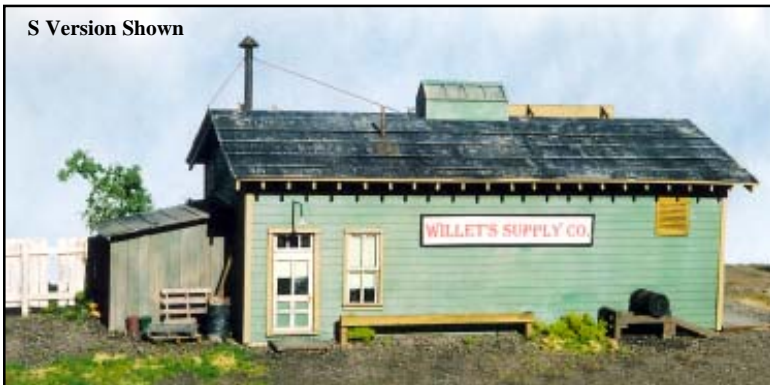

S Version Shown

Willet's Supply Co.

Willet's Supply Company represents a small trackside firm dealing in just about anything! If they don't have it, you probably don't need it! Loading dock and freight doors are on the back and right side. Approx. Size - 45' x 24'

#37435 TT Scale

New River Yard Switcher Shed

The Milwaukee Road used this simple single-stall shed to store the local steam switcher. Then after the diesels came, the smoke jack was moved to the center. On the model, the smoke jack can be positioned in either location. The footprint is approximately 21' x 70'.

#37502 TT Scale Soon!



S Version Shown

Assorted Stations



These structures are based upon real structures for the modeler who wants to model a specific area or road, and they will work well for many other lines also. All wood kits are laser-cut, but urethane and/or plaster is used where it works better.



DT&I Standard Station, Waiting Room Right

Approx. Size - 22' x 45'

#27118 HO Scale



DT&I Standard Station

According to the *Model Railroader* article, these stations were built by the Ohio Southern around the turn of the last century. Eight stations were built, some were mirror images placing the waiting room on either the left or right side, and most still existed into the late 1970's.

This kit consists of laser-cut basswood, plywood, and cardstock, detail castings, and loads of accurate details. The windows and doors are positionable; window sashes are self-adhesive wood to make glazing much easier. Interior partitions and floors are included. The tabbed, well-engineered construction provides fast and easy assembly. The footprint is about 22' x 45'. It is based upon the drawings in the Sept 1978 *Model Railroader*.

DT&I Standard Station, Waiting Room Left

Approx. Size - 22' x 45'

#27119 HO Scale

West of Bellevue, Ohio stands Green Springs Junction. Until around 1972, the NKP used this station. Over the years, the original depot was modified with large doors in the baggage room. The one on the front of the depot provided covered storage for a handcar.

This kit consists of laser-cut basswood, plywood, and cardstock, self-adhesive shingles, detail castings, and loads of character. It was based upon a Nickel Plate Road prototype. The doors are positionable, and floor and interior partitions are included. The tabbed, well-engineered construction provides fast and easy assembly. Approx. Size - 24' x 52'

#07162 S Scale

#27162 HO Scale

Nickel Plate Road Green Springs Depot



Maryland & Pennsylvania Laurel Brook Station

Laurel Brook, Maryland was the location for this station and was used from around 1900 until 1954.

This kit consists of laser-cut basswood, plywood, and cardstock, self-adhesive shingles, detail castings, interior scribing and bench, and loads of character. It was based upon a Ma & Pa prototype. The tabbed, well-engineered construction provides fast and easy assembly. Approx. Size - 12' x 15'

#07171 S Scale



East Broad Top



64' x 75' area required!
1935 O Scale Version Shown

B.T.S. is proud to offer the all-important, magnificent **Orbisonia Station** - perhaps the one building that makes the E.B.T. the classy railroad that it is - in S scale and in O scale in the original, as-built 1908 version without the front canopy and restroom bay on the back, the 1935 version with the canopy and bay, and the final way the station looked in 1955 after the post office was moved to the south end and new doors were added.

Orbisonia Station

Three Versions - 1908, 1935, 1955

- #07127 S Scale
- #17127 O Scale
- #27127 HO Scale - Planned!

Limited Edition!

PRECISION LASER-CUT

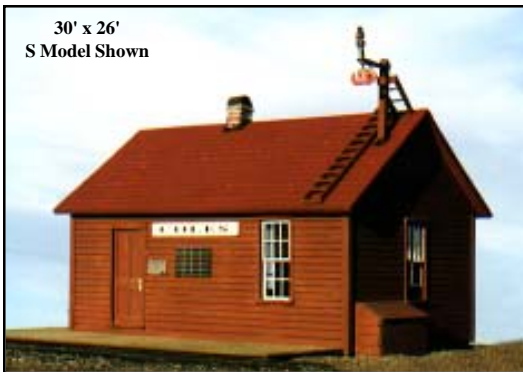
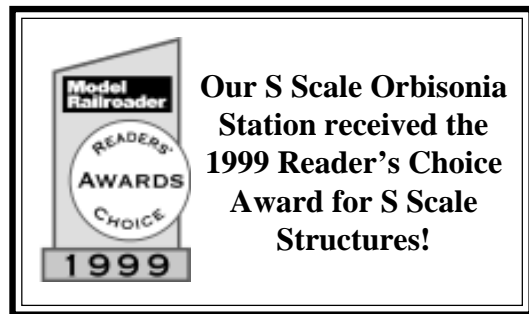

30' x 26'
S Model Shown

Three Springs Station

- #07122 S Scale
- #17122 O Scale

Coles Station

- #07124 S Scale
- #17124 O Scale
- #27124 HO Scale

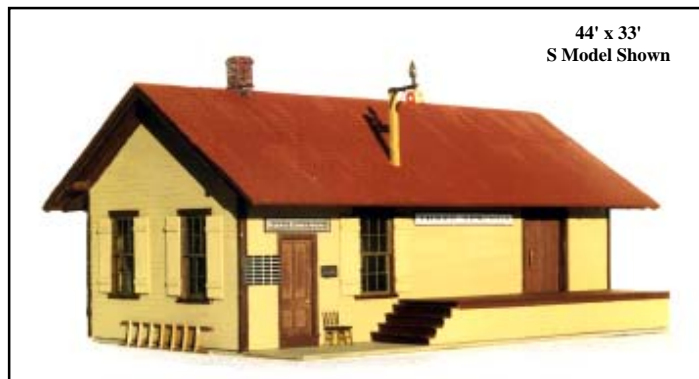

44' x 33'
S Model Shown

Our laser-cut kits offer the modeler an excellent combination of accuracy and ease of construction. With window and door openings cut out, slots and tabs for proper part alignment, and the ability to capture the varying board width as used by the East Broad Top, laser-cut kits are a must! Our kits feature individual upper and lower window sashes, interior floors and partitions (where known), different width boards on the gables, and an order board that is the correct E.B.T. version. Pressure-sensitive three-tab shingles and decals are included.

East Broad Top



The E.B.T. at Saltillo, PA

The Saltillo station features a loading dock, operator's bay, and the typical charm of the East Broad Top. This station is still standing, although it is in need of major restoration. Sadly, the water tank burned over ten years ago. Only the concrete foundation remains today.



Saltillo Station

#07123 S Scale
 #17123 O Scale
 #27123 HO Scale

**HO, S & O
 In Stock!**



Saltillo Tank

#07130 S Scale
 #17130 O Scale
 #27130 HO Scale

**Almost
 Ready!**

The E.B.T. at Mt. Union, PA

At Mt. Union, the E.B.T. interchanged with the PRR. The Timber Transfer was a landmark that originally moved timber and later hoisted standard gauge freight cars to allow narrow gauge trucks to be installed!



Timber Transfer

#07125 S Scale
 #17125 O Scale
 #27125 HO Scale

**FUTURE
 RELEASE**

The E.B.T. at Robertsdale, PA

The concrete block Robertsdale Station is currently the home of the museum for the Friends of the East Broad Top. It has been kept in good condition by the Friends and the historical collection is open to the public.



Robertsdale Station

#07126 S Scale
 #17126 O Scale
 #27126 HO Scale

**FUTURE
 RELEASE**

Waynesburg and Washington

According to Koehler and Gayvert in Three Feet on the Panhandle, the Waynesburg and Washington Railroad was a three-foot, narrow gauge line formed in 1875 in southwestern Pennsylvania. Acquired by the Pennsylvania Railroad in 1885, it was a steam railroad until 1933 when the last fire was dropped. Rail service continued until the late 1950's using gas-powered vehicles. For some time, the rolling stock even had PRR lettering!

Iams Station

Iams is located near milepost 20 about one-third of the way from Waynesburg to Washington, PA. The station is still standing as of 2003, but has been covered with corrugated siding. A 407' passing siding ran between the station and the main line. Very few photos of the station exist today. Your layout can feature this station! As part of our Waynesburg & Washington series, the Iams Station is now available.

This kit consists of laser-cut basswood, cardstock, and plywood, styrene roofing, and correctly-spaced siding. The tabbed construction eases assembly. Interior floors are included. Platform size - 44' x 28'. **HO Scale #27600**



West Amity Station

West Amity is located near milepost 12. The station was moved to a farm a few years ago, and converted to a storage building.

This kit consists of laser-cut basswood, cardstock, and plywood, styrene roofing, and individual batten siding. The tabbed construction eases assembly. Interior floor & wall is included. Platform size - 22' x 24'.

HO Scale #27603

W&W Deer Lick Station

Deer Lick is located near milepost 19 on the Waynesburg & Washington. Consisting of two rectangular buildings connected end-to-end, it also features an angled covered loading dock on one end. This kit consists of laser-cut basswood, cardstock, and plywood, styrene roofing, and correctly-spaced siding. The tabbed construction eases assembly. Interior floors are included. **HO Scale #27601**



W&W Waynesburg Roundhouse

Originally a six-stall wood roundhouse, the left stall was converted to a machine shop leaving only five. This kit consists of laser-cut basswood, cardstock, and plywood, interior floor and timber framing, and positionable doors and windows. The tabbed construction eases assembly. Interior floors are included. **HO Scale #27602**



2-6-0 Kits

We are working on our next narrow gauge steam loco, the Waynesburg and Washington 2-6-0 in HO_n3. Our loco kits feature etched brass parts, lost-wax brass and white metal detail castings, white metal boilers & cabs, and loads of accurate details. Illustrated instructions provide an easy assembly. Two kits will be offered allowing the modeler to build all seven of the W&W locos featuring two different tenders and varying details.



W&W 2-6-0 Photo - Jim Weinschenker Collection

Welcome to Cabin Creek



This series includes the smaller laser-cut structures that follow the theme of Cabin Creek, a fictional town that supports the sawmill, pulp mill, railroad, or coal mine. These may be based upon real buildings or may be totally freelanced, but in either case, they will all work well together on most any layout.

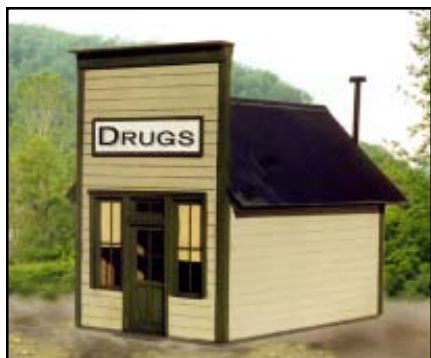

SMALL STORE

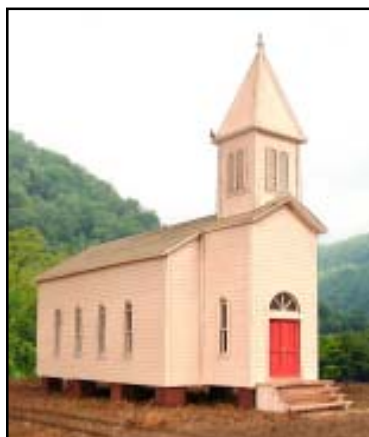

RURAL CHURCH



GREELEY'S PLACE



BOOT REPAIR



BRANCHLINE WATER TANK



EAST END GROCERY



POST OFFICE



SLADE'S OFFICE



FLAGSTOP STATION



CLEATOR'S GAS



Singer Watch Repair



CLEGG'S CABIN

Cabin Creek Series

Small Store

A simple, one-man operation that could house a drug store, hardware, post office, or just about anything. This design has survived the years, and can still be seen standing today.

This kit packs a load of detail into a footprint of only 12' x 20' and features tar paper roofing, complex window trim, and extremely easy assembly.

S Scale	#07225
O Scale	#17225
HO Scale	#27225

Greeley's Place

Greeley's Place is typical of the backwoods cabin built to just provide basic shelter. There was nothing fancy about Greeley, and there certainly wasn't anything fancy about his place. He built it back before the "war to end all wars" with rejects from the local sawmill. No one has seen Greeley for some time now; it is rumored that he has taken up with a "city woman" down in the flatlands.

This kit consists of laser-cut basswood and plywood, individual battens and tar paper roofing. In addition, the battens can be left off to create a plain board cabin. The footprint is about 16' x 18'.

S Scale	#07227
O Scale	#17227
HO Scale	#27227

Boot Repair Shop

The Boot Repair Shop is a most-necessary item in an area where miners, loggers, or railroad men work. Work boots were valuable tools to these guys.

The model was inspired by a photo of the original building that stood in California. A 1920-photo of it was shown in the May-June 1998 *Gazette*. The kit consists of laser-cut basswood, plywood, and matt board, tar paper roofing, signs, wire mesh, and detail castings. The footprint is about 15' x 24'.

S Scale	#07230
O Scale	#17230
HO Scale	#27230

Post Office

Every small town has a post office. In many places, in addition to sending and receiving mail, it is the center gathering place in town where folks share information and gossip. This kit consists of laser-cut basswood, plywood, cardstock, adhesive-backed shingles, and detail castings. The footprint is about 16' x 26'.

S Scale	#07233
O Scale	#17233
HO Scale	#27233

East End Grocery

The small grocery store helped rural America change from a farming community to an industrial center. The railroads, mills, and mines had long workdays which left little time for working the fields and gathering crops. A small garden was about all that could be handled. The grocery store stepped in and conveniently provided folks with the dry goods, vegetables, and meat products needed to sustain life.

The kit consists of laser-cut basswood, plywood, and matt board, adhesive-backed shingles, signs, and basic interior components including counter, wood shelving, and assorted boxes and barrels. The footprint is about 18' x 34'.

S Scale	#07226
O Scale	#17226
HO Scale	#27226



Rural Church

Sunday mornings found most of the Cabin Creek folks in their simple church getting the word. Hopefully, the word was strong enough to last all week long. From the top of the steeple to the simple porch and steps, this is typical of churches in many small towns.

The kit consists of laser-cut basswood, plywood, cardstock, and detail castings. The footprint is about 24' x 56'.

S Scale	#07232
O Scale	#17232
HO Scale	#27232

Branchline Water Tank

Steam locos must have water, and the local water tank provided for their needs. This is a freelanced model of an unsophisticated 20,000-gallon tank based upon several different prototype tanks. The height is about normal for use with narrow gauge, but it will work well for smaller standard gauge locomotives. If a bit of extra height is needed, the ground under the tank can be raised.

The kit consists of laser-cut basswood, plywood, styrene, and detail castings. A sheet of laser-cut, see-through 'water' is included! The footprint is about 18' x 22'.

S Scale	#07114
----------------	---------------



Cabin Creek Series



Clegg's Cabin

A simple little cabin that features laser-etched nail holes, self-adhesive shingles and detail castings. Easy to build, this should be your first laser-cut kit. Approx. Size - 12' x 19'.

S Scale #07470
O Scale #17470
HO Scale #27470

Slade's Office

This kit makes a perfect small structure for use as an office of any sort or perhaps even a house! The kit consists primarily of four wall castings (White Metal in HO, Urethane in S & O) and several small detail castings. Laser-cut rafter tails, roof and porch are included. Approx. Size - 22' x 24'.

S Scale #07430
O Scale #17430
HO Scale #27430

Alfred, Bascom & Co. Hardware

The ABC Hardware store provided a means for making a living, and a small living quarters for the owners above the selling floor. In later years, the owners lived in a larger house, and gave the head clerk free room as part of his pay. Expansion after the great depression resulted in the addition of the office on the side. This kit consists of laser-cut basswood, plywood, adhesive-backed shingles, and signs. The footprint is about 45' x 45'.

S Scale #07228
O Scale #17228
HO Scale #27228

Cleator's Gas Station

This little gas station is based on an actual station from the late 1920's. The kit comes complete with gas pumps, island, station, color signs and other details for a fantastic model. The interior even stands ready for full detailing. Gas station detail kit # 20774 turns this kit into a fantastic model. Approx. Size - 22' x 11'.

HO Scale #27410

Flagstop Station

The perfect small town depot or wayside station for your pike! This depot is based on a southern prototype, but it is generic enough for nearly any location. Approx. Platform Size - 40' x 19'.

S Scale #07400
O Scale #17400
HO Scale #27400

Singer Watch Repair

Mr Singer was always busy keeping the railroad watches cleaned and keeping perfect time. Watch repair is always needed in any town. This kit consists of laser-cut basswood, plywood, and signs. Approx. Size - 14' x 27'.

S Scale #07234
O Scale #17234
HO Scale #27234

Note - The Red Eye Saloon and Kee's Chinese Laundry also work well in Cabin Creek!



L to R - Post Office, East End Grocery, Boot Repair, Small Store



L - R.... Kee's Chinese Laundry, Small Store, Boot Repair, Clegg's Cabin, Red Eye Saloon. Post Office is in the foreground.

Stop by Cabin Creek!

O scale versions shown. All kits are available in S and HO scales also!



Below... Handcar Shed, Flagstop Station

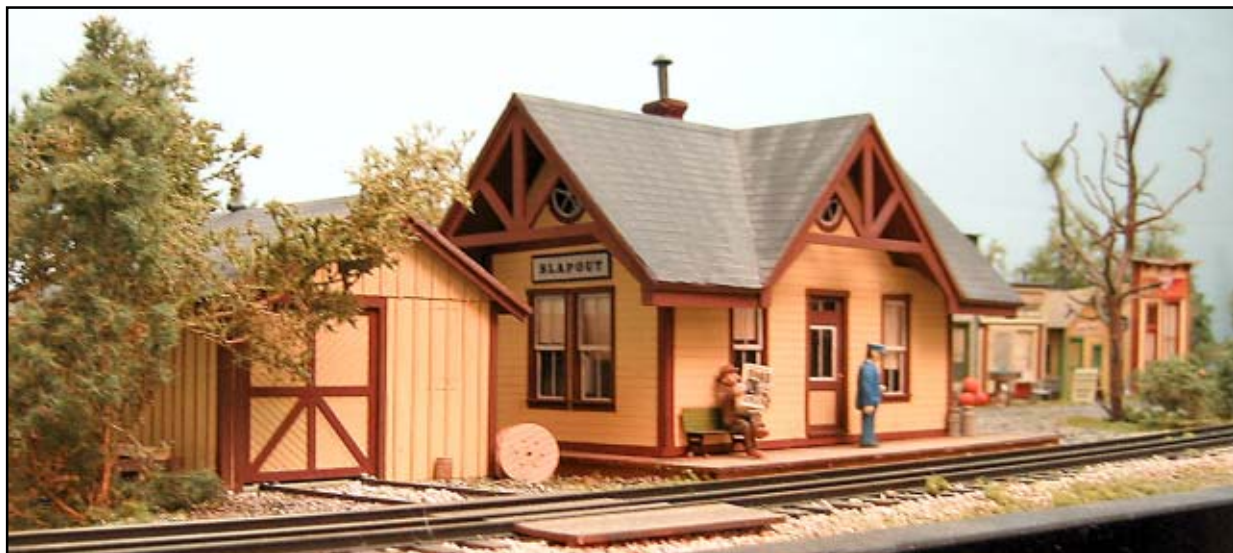

Goin' Home Series



The "Goin' Home" series pays tribute to life in rural America during the first half of the Twentieth Century. Unless raised in New York City, each of us has memories of our home town back when we were growing up. Life seemed sweeter, the summers were longer, and the trains were better. Makes you smile just thinking about it. Now you can recreate it on your layout. Future releases include other shotgun houses and many of the small town buildings that helped define our way of life.

While it is a freelanced structure, the Elliott & Sons Supply was based upon a tomato packing house in Sarasota, Florida. As for the model's use, well, that is up to you. The kit features laser-cut basswood, cardstock and plywood; tabbed, easy construction; loads of Detail Castings; laser-cut, self-sticking shingles & sashes; laser-etched nail holes; optional skylights; and a 40' x 60' Footprint.



Elliott and Sons Supply

- #08106 S Scale
- #18106 O Scale
- #28106 HO Scale



Anderson Pulpwood Yard

At the yard, small truck loads of pulpwood, small logs cut into about five foot lengths, are loaded onto pulpwood cars for shipment out to the mill. Stacks of pulpwood can be seen around the yard waiting for the arrival of the next empty wood rack - slang for the pulpwood car.



The Anderson Pulpwood Yard kit includes the office, storage shed, truck scale, oil drum rack, two wood racks, signage, raw materials for pulpwood, and over twenty metal detail castings. Laser-etched nail holes, self-adhesive shingles and window sashes, and tabbed construction are features of this laser-created kit. Office and scale footprint is 34' x 40'.

- #07480 S Scale
- #17480 O Scale
- #27480 HO Scale

Goin' Home Series



JUNIOR'S SHINER

Junior's Shiner

A perfect little, "down by the tracks" mobile home fit for the 1930's to the present time. The kit includes venetian blinds, detail castings, and color awning.

Approx. Size - 34' x 22'

#07405 S Scale

#17405 O Scale

#27405 HO Scale



BEST AUTO GARAGE

Best Auto Garage

This kit makes a perfect ultra-detailed gas station and garage scene. Starting life as a livery stable, it changed with the times! It comes complete with an interior, laser-cut parts, color decals, and loads of white metal and brass details. Approx. Size - 28' x 30'

#27415 HO Scale



PRITCHARD'S BARN

Pritchard's Barn

This kit is just right for a small barn or a small shop-style building. It comes with a removable roof, full interior framing and detail castings. Approx. Size - 36' x 18'

#07420 S Scale

#17420 O Scale

#27420 HO Scale

Willet's Supply Co.

Willet's Supply Company represents a small trackside firm dealing in just about anything! If they don't have it, you probably don't need it! Approx. Size - 45' x 24'

#07435 S Scale

#17435 O Scale

#27435 HO Scale

#37435 TT Scale



WILLET'S SUPPLY

Babe's Diner

This charming Art Deco wonder captures the American diner of the past. America was once dotted with many such establishments before the appearance of modern fast food chains. Approx. Size - 50' x 20'

#27440 HO Scale



BABE'S DINER

Goin' Home Series



Tobacco Barn

Tobacco has long been a staple part of the southeastern commerce. After picking, the tobacco leaves must be dried before selling. The leaves are strung together in bunches and hung over poles in drying barns. This barn can be used either for drying or for storage of dried leaves. The inspiration for this kit is a barn that stood in South Carolina and was featured in *Railroad Model Craftsman*.

This kit consists of laser-cut basswood and plywood, corrugated metal and tar paper roofing, and white-metal detail castings. The doors can be positioned open or closed. The footprint is about 35' x 26'.

- #07304 S Scale
- #17304 O Scale
- #27304 HO Scale



Shotgun House, Type I

Shotgun houses are so named because, supposedly, a shotgun fired through the front door would pass straight through the house and out the back door. Rooms were as wide as the house, and had doors that connected straight through. These were typically used as low-cost housing for the low-income workers of the South. Many are still in use today, and some have been restored to a level of grandure that did not exist when they were first built.

This kit consists of laser-cut basswood, plywood, and cardstock, optional porch, and detail castings. The windows and doors are positionable. The footprint is about 17' x 52'.



- #07300 S Scale
- #17300 O Scale
- #27300 HO Scale
- #27301 HO Scale Three-Pack

The Shanty

Based upon a still-standing southern Georgia sharecropper's shack, the shanty is a typical small farm house. The outhouse is included as are laser-engraved nail holes, tar paper roofing, individual battens, and detail castings. Approx. Size - 44' x 24'.

- #07110 S Scale
- #17110 O Scale
- #27110 HO Scale



THE SHANTY

2nd Street Series

In many small towns across America, Main Street was the location for the businesses. First Street, one block over from Main, was where you could find the fancy town homes of the folks who owned the businesses on Main Street. Another block over, the homes were nice, but not quite as fancy as those on First St. This is where the clerks, salesmen, and other white-collar workers lived. The 2nd Street series will include a variety of single family homes.

#110 2nd Street

S Scale 07700
O Scale 17700
HO Scale 27700



“#110 2nd Street” is typical of the houses in all small towns across America dating from the early 1900's until today - Three bedrooms upstairs with living room and eat-in kitchen downstairs. Shutters can be left off or attached. The sun&air-operated clothes dryer, aka clothes line, is included.

This kit consists of laser-cut basswood, cardstock, and plywood, peel&stick diamond shingle roofing, and positionable doors and windows. The tabbed construction eases assembly. Interior floors are included. Footprint is 19' x 40'.



Coming in the series ...

- #112 2nd St.
- #114 2nd St
- #116 2nd St
- #118 2nd St

New River Yard Series



The Railroad Yard: a place filled with some very specialized buildings and lots of excitement. In our New River Yard, you will find the structures that make up the large rail division point. Roundhouses, offices, shop buildings, storage sheds, freight houses, locomotive service facilities, and lots more. Using prototype structures that have a generic look, we will be offering everything needed to build a complete rail yard.

New River Yard Freight House

- #07500 S Scale
- #17500 O Scale
- #27500 HO Scale



Unless your company had its own rail siding, chances are good that your wagons or trucks carried your shipments to the railroad's freight house for shipment. At the freight house, the goods were logged in, the paperwork and billing done, and the goods were stored until the next outgoing freight car was available. Incoming goods were handled the same way.



The goods were stored until the next outgoing freight car was available. Incoming goods were handled the same way.

This is a variation of the CB&Q prototype. The footprint of the building is 74' x 20' with a 30' loading dock on the end. It can be built with scribed siding or board & batten.



New River Yard Narrow Gauge Boxcar Storage Shed

- #07507 S Scale
- #17507 O Scale
- #27507 HO Scale

There is never enough storage space in the yard. And the cheapest storage available is to use old, worn-out pieces of rolling stock. This shed is based upon the one that stood at the Sierra Railroad. The footprint is approximately 7' x 19'.

New River Yard Series

MoW Shed

- #07501 S Scale
- #17501 O Scale
- #27501 HO Scale

Maintenance of Way, i.e., the maintenance of the track and roadbed requires the railroad to keep a stockpile of spikes, tie plates, switch stands, and other components.

This kit consists of laser-cut basswood, plywood, and cardstock, tarpaper roofing, detail castings, and loads of character. It was based upon an AT&SF prototype. The doors are positionable, and individual battens are included if board-and-batten siding is desired. The tabbed, well-engineered construction provides fast and easy assembly. The footprint is about 22' x 29'.



Handcar Shed

- #07503 S Scale
- #17503 O Scale
- #27503 HO Scale

Track gangs needed a place to store their handcars when not in use as well as all their tools and supplies. Sheds with tracks quickly answered the need. The prototype for this model was near Delta, PA on the Maryland & Pennsylvania Railroad. The footprint is approximately 18' x 20'.

Single-Stall Switcher Shed

- #07502 S Scale
- #17502 O Scale
- #27502 HO Scale
- #37502 TT Scale

The Milwaukee Road used this simple single-stall shed to store the local steam switcher, then after the diesels came, the smoke jack was moved to the center. On the model, the smoke jack can be positioned in either location. The footprint is approximately 21' x 70'.



The Pennsylvania Railroad took an old MoW kitchen car and placed it on the ground at Sodus Point, NY where it served the railroad for many years as a storage place for welding equipment. The footprint is approximately 14' x 48'.

Welding Shop

- #07504 S Scale
- #17504 O Scale
- #27504 HO Scale



Gas Engine Repair

- #07505 S Scale
- #17505 O Scale
- #27505 HO Scale

As more trucks were added to the railroad, and motorized cars replaced the 'hand' car, the need to maintain and repair these gas and small diesel engines increased. The footprint is approximately 29' x 29'.



New River Yard Series



Two-Stall Engine House

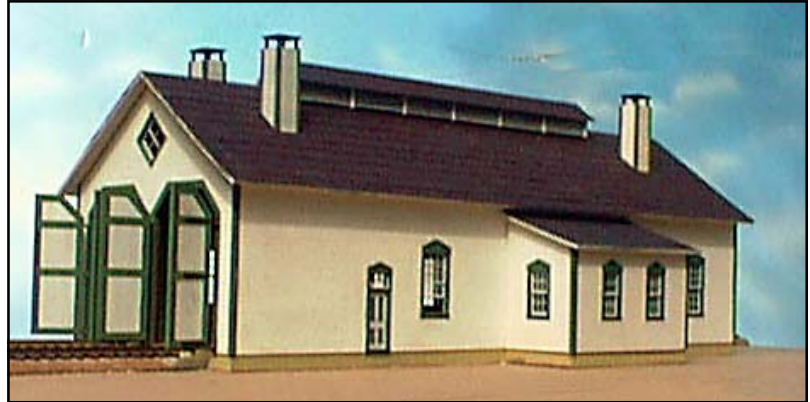

This kit consists of laser-cut basswood, plywood, and cardstock, tarpaper roofing, detail castings, and loads of character. The tabbed, well-engineered construction provides fast and easy assembly. All doors and windows are positionable open or closed. Individual vent slats in the roof clerestory provide a very realistic feature while being easy to construct. Interior features include scribed flooring, scribed walls, roof framing, columns and beams, smoke funnels, work benches, and removable roof. *Note - the model shown is not quite finished; still have some details and weathering to add!!!*

The footprint of the building is 41' x 101' with a 12' x 24' Shop. Interior length of each stall is 96'. Room enough for a USRA 2-8-2 or 4-6-2.

#08115

S Scale



Rail, Ties, and Locos are not included!



General Yard Structures

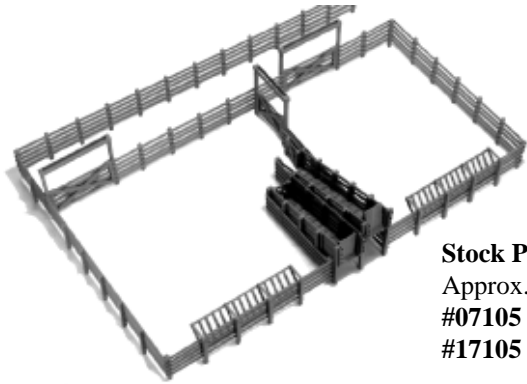

Stock Pens, N&W
 Approx. Size - 43' x 61'
#07105 S Scale
#17105 O Scale



Ballasted Deck Trestle, A.C.L.
 Approx. Size - 16' x 50'
#07103 S Scale
#17103 O Scale
#27103 HO Scale
#37103 TT Scale



Team Track Office
 Southern Railway
 Approx. Size - 12' x 14'
#07107 S Scale
#17107 O Scale
#27107 HO Scale



Tool Storage Shed
 Approx. Size - 12' x 14'
#07112 S Scale
#17112 O Scale
#27112 HO Scale



Crossing Shanty
 Approx. Size - 12' x 14'
#07111 S Scale
#17111 O Scale
#27111 HO Scale



JD Interlocking Tower, NH
 Hydrocal Plaster Kit
 Approx. Size - 27' x 32'
#07113 S Scale

Utility Building Combo
 One each of 27107, 27111, 27112
#27116 HO Scale



Loading Dock Approx. Size - 16' x 85'
#07102 S Scale
#17506 O Scale
#27506 HO Scale



LCL Ramp
 Approx. Size - 12' x 32'
#07509 S Scale
#17509 O Scale
#27509 HO Scale

General Yard Structures



Bridge Crane

Overhead bridge cranes were located at various places including the team track, engine house, large industries and the freight house. It was used to move heavy loads to and from flats and gons.

The model is a brass import. The hoist trolley is positionable on the bridge. The model is painted and ready for you to simply hang the hook and chain on the hoist.

Approx. Size - 20' wide with 16' clearance from ground to the bottom of the bridge.

#18505

O Scale



**Sold
Direct Only**

ET&WNC Series



Original B&W photo above by Ed Bond was published in the Spring 1992 Blue Ridge Stemwinder and is used with permission from John R Waite.

East Tennessee and Western North Carolina RR Co. Howe Thru-Truss Covered Bridge

According to the East Tennessee and Western North Carolina Railroad Historical Society publication, The Blue Ridge Stemwinder, the Hampton, TN covered thru-truss bridge was built in 1881 as an open bridge, then rebuilt and covered around 1892. The 118' bridge survived the abandonment of the line in 1950, but a few years later was torn down. Photos of the prototype can be seen in the Spring 1992 edition of the Stemwinder.

The model consists of laser-cut wood parts that build into a realistic, and very strong, bridge. The roof is removable for maintenance. Includes two stone walls for the abutments; rail and spikes are not included. Approx. Size - 18' x 118'



#07140 Sn3

#27140 HOn3



More Bridges & Trestles

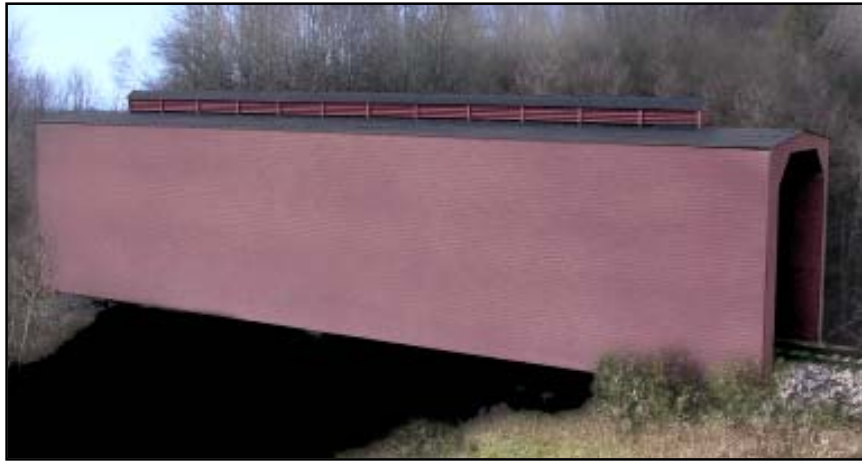

Thru-Truss Covered Bridge

Based upon the East Tennessee and Western North Carolina Railroad, Hampton, TN covered thru-truss bridge, this 118' bridge has been widened and increased in height to handle standard gauge equipment.

The model consists of laser-cut wood parts that build into a realistic, and very strong, bridge. The roof is removable for maintenance. Includes two stone walls for the abutments; rail and spikes are not included. Approx. Size - 22' x 118'

#07141 S Scale



Cheat Run Trestle

Not all trestles are tall or long. In many areas, small trestles are used to cross gullies and stream, and this one is about eight scale feet above the stream bed. The Cheat Run trestle is patterned after one built in 1906 in Illinois.

The model consists of laser-cut wood parts that build into a realistic, and very strong, trestle. Rail and spikes are not included. Approximate Size - 13' x 27'

- 07142 Cheat Run Trestle, S
- 07143 Cheat Run Trestle, Sn3
- 17142 Cheat Run Trestle, O
- 17143 Cheat Run Trestle, On3/30
- 27142 Cheat Run Trestle, HO
- 27143 Cheat Run Trestle, HOn3/30



Best of the West!



The Old West! One of the best things in American history is the romance of the old west. Cowboys, dancehall girls, sodbusters, ranchers, cattle drives, rail heads, outlaws, and all the rest blend together to form a wonderful modeling opportunity. The expanding line of *B.T.S.* structures that honor the west makes this an easy task.



BUCK'S DYNAMITE BUILDING

Buck's Dynamite Building

This model features highly detailed simulated stone, brick and cement walls. The masters were done for us by the late Bill Turner of Arkansas Valley Scale Models. The building is unique and fits into any mining or logging scene. Walls are white metal castings. Approx. Size - 28' x 16'.

#27455 HO Scale



RED EYE SALOON

Red Eye Saloon

This unique false-front building represents a small saloon like those found in most western boom and logging towns from the mid 1800's to the 1950's. This kit has a small footprint allowing it to fit on any layout. Full color signs are included. Approx. Size - 15' x 25'.

#07460 S Scale

#17460 O Scale

#27460 HO Scale



KEE'S CHINESE LAUNDRY

Kee's Chinese Laundry

Our small Chinese laundry is like those found in most western towns from the mid 1800's to the 1950's. Many boom and logging towns had such establishments along the side streets.

This kit has a small office on the side. Full color signs are included. Approx. Size - 22' x 25'.

#07465 S Scale

#17465 O Scale

#27465 HO Scale

Other structures that fit the western look...

- Cabin Creek Rural Church
- Cabin Creek Small Store
- Cabin Creek Slade's Office

**Sold
Direct Only**

War Between the States *B.T.S.*

Laser-cut wood and cardstock are used to create a series of cars that saw service during the War between the States and on through the expansion of the West. Cars are based upon data from prototypes of both the North and the South. All are less trucks, couplers, and decals.

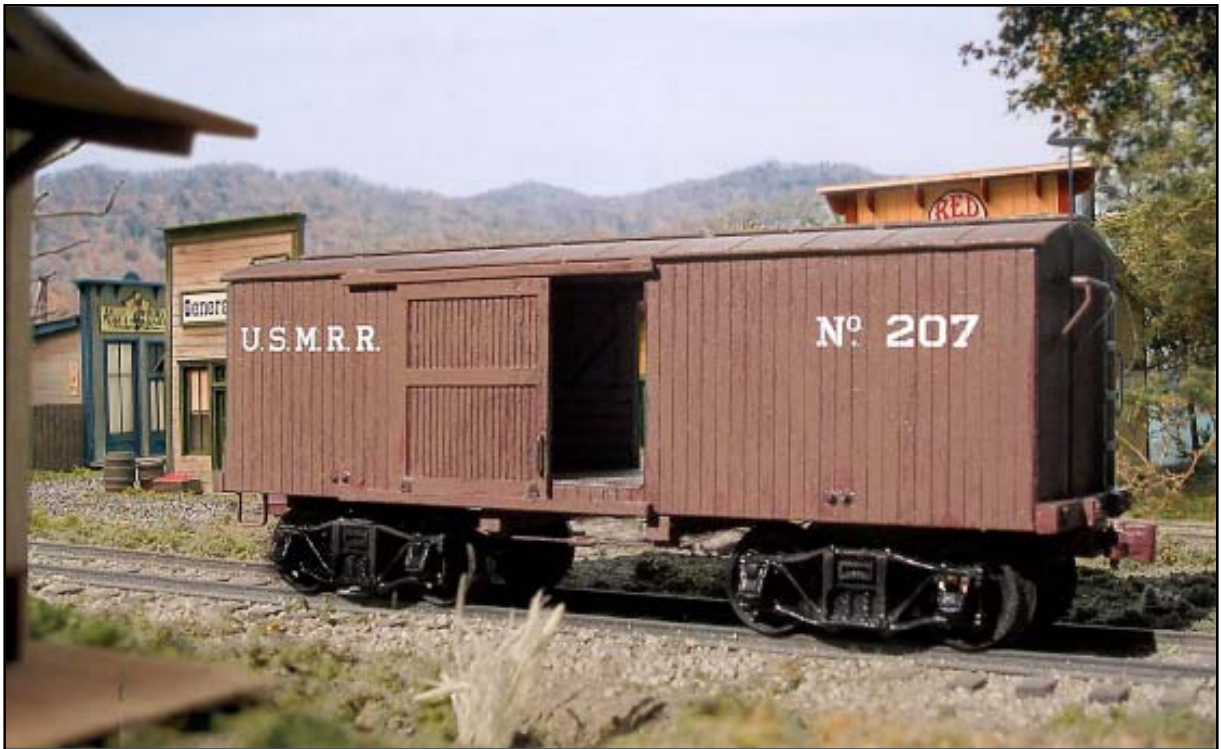

USMRR House Car

About one-third of the freight rolling stock during the early 1860's was the house car, today called a 'boxcar.' The railroads were in the early stages of development, and so were the freight cars. House cars of this type with varying details were seen in many of the early war photos.

This radial-roof car allows the modeler some flexibility. The representative tin roof can be left off and a tar/canvas roof can be applied. The truss rods were just coming into popularity, and they varied between four truss rods, two on the outside of the car, two near the center beam, or none at all. The model will build into any of these versions. In addition, the model features the interior bracing, flooring, and positionable doors.

The model features laser-cut wood and cardstock components with hardware in plastic and lost-wax brass. Less decals, trucks and couplers.

- #29507 HO Scale USMRR House Car
- #29508 HO Scale USMRR House Car Five Pack
- #19507 O Scale USMRR House Car

Mantua General shown with the House Car



**Sold
Direct Only**

War Between the States *B.T.S.*

Laser-cut wood and cardstock are used to create a series of cars and structures that saw service during the War between the States and on through the expansion of the West. Cars are based upon data from prototypes of both the North and the South. All car kits are less trucks, couplers, and decals.



Covered Wood Rick

Rick is an old agricultural term for a large quantity of hay or straw stacked into a rectangular shape for storage and covered at the top to protect it from weather. It seems likely that early railroader, fresh off the farm, looked at the piles of wood for the locomotives, and called them the same thing.

This kit will build two, scale 40' long ricks, or they can be combined into one of 80' length. The model features laser-cut wood components including laser-engraved nail holes, and material is included to create the cut firewood.

#27800 HO Scale Covered Wood Rick (2-Pkg)

#17800 O Scale Covered Wood Rick (2-Pkg)

Open Wood Rick



Rick is an old agricultural term for a large quantity of hay or straw stacked into a rectangular shape for storage and covered at the top to protect it from weather. It seems likely that early railroader, fresh off the farm, looked at the piles of wood for the locomotives, and called them the same thing.

This kit will build two, scale 40' long ricks, or they can be combined into one of 80' length. The model features laser-cut wood components including laser-engraved nail holes, and material is included to create the cut firewood.

#27801 HO Scale Open Wood Rick (2-Pkg)

#17801 O Scale Open Wood Rick (2-Pkg)

**Sold
Direct Only**

War Between the States *B.T.S.*

Laser-cut wood and cardstock are used to create a series of cars that saw service during the War between the States and on through the expansion of the West. Cars are based upon data from prototypes of both the North and the South. All are less trucks, couplers, and decals.

USMRR Flat Cars

The conflict that started in 1861 ushered in many new weapons and methods, and from that time on, warfare was changed by the advantage of the railroad. Troops and supplies were able to be moved quickly where needed.



The US Military Railroad was established to help coordinate the many small railroads into one large useful system. New rolling stock was ordered, and the flat car, became one of the most versatile cars on the lines.

This nine-stake flat car can be built with the brake wheel on the deck as shown or attached to the end sill. Both versions have been noted in photographs from the period. Wood stakes are included to help hold on any loads. Photos of these cars show loads of lumber, rail, barrels, and even piles of dirt! The model features laser-cut wood and cardstock components with hardware in plastic and lost-wax brass. Less decals, trucks and couplers.

#29509 HO Scale
USMRR Nine-Stake
Flat Car

#29510 HO Scale
USMRR Nine-Stake
Flat Car, 5-Pack

#19509 O Scale
USMRR Nine-Stake
Flat Car



This five-stake flatcar features a deeper side sill than the nine-stake flatcar. Wood stakes are included to help hold on the loads. Photos of these cars show loads of lumber, rail, barrels, and even piles of dirt!

The model features laser-cut wood and cardstock components with hardware in plastic and lost-wax brass. Less decals, trucks and couplers.



#29517 HO Scale
USMRR Five-Stake
Flat Car

#19517 O Scale
USMRR Five-Stake
Flat Car

B.T.S. Car Shops

CLEAR CREEK MODELS

**Sold
Direct Only**

The Clear Creek line includes a series of HO_{n3} kits for the early rolling stock used in the West. All of these kits, other than kit 401, have been switched over to laser cut wood, injection molded plastic and brass parts to improve the quality and over all realism of the models. Detailed assembly instructions and drawings are provided. All are less trucks, couplers, and decals.



#29403 - Colorado Central 24' Box Car
The C.C. built 70 24' Box Cars with 24,000-lb. capacity.



#29413 - DSP&P, C&S 27' Box Car
The 27' Box car was built in 1880-1881 for the DSP&P.



#29405 - DSP&P Tiffany Refrigerator Car
The Tiffany Summer and Winter Car was one of the first cars built especially for refrigeration.



#29409 - CC Excursion Car
The Colorado Central Railroad rebuilt six of their 26' flat cars into excursion cars. The roof and sides were supported by either 12 or 16 stakes. Two benches were added that ran down the center of the car. Figures are not included.



#29407 - DSP&P Flat/Gondola Car
This basic 26' car was the most widely used on the system. This kit provides parts for any one of the following cars: flat car, lime car, lumber cars, log car or coal loader.



#29411 - Covered Ore Car
This unusual car was built in the Colorado Central shops from a flat or gondola car. The car may have been used to haul black powder and/or other commodities.



#29401 - Silver Plume & Montezuma Ore Car
The model represents a 3-ft. gauge, 18 ton ore car, similar to the smaller Gilpin Tramway 2-ft. gauge ore cars that hauled thousands of tons of gold ore from the mines to the mills.



#29421 - West Side Standard Flat Car
The largest single portion of the West Side roster was devoted to 24' flat cars. The total number of these cars constructed was in excess of 300 units.

**Sold
Direct Only**

Car Shops **B.T.S.**

CLEAR CREEK MODELS



#29415 - Russel Wheel & Foundry Skeleton Log Cars
These cars were used with minor variations on a great number of Northwestern logging railroads such as Mich-Cal Lumber Co., Carter Brothers Lumber and the Feather River Lumber Company.



#29417 - D&RG 1878 Standard Box Car
The D&RG owned more of this 10-ton 24' box car than any other box car in its history. The cars were also sold to the RGS, the Silverton Railroad and the Silverton Northern Railroad, and similar cars ran on the Nevada Central.



#29419 - RGS 24' Box Car
These 10-ton 24' box cars were built by the D&RG in 1881. The original series numbers were 3167 to 3279 on the D&RG. They were sold to the RGS in 1891.

These craftsman kits are less trucks, couplers and decals. In many kits, sufficient material is included to build one of several different versions.

West Side Lumber Co. / Swayne Lumber Co.

O Scale Skeleton Log Cars

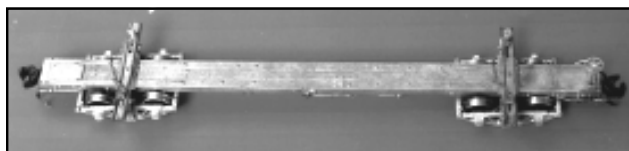

These brass log cars feature the brake detail, moving cheese blocks on the bunks, couplers and decals. Chains are in the package. All cars are painted West Side Red; decals are in the box.

Two versions of this car, O standard and On3, are still available!

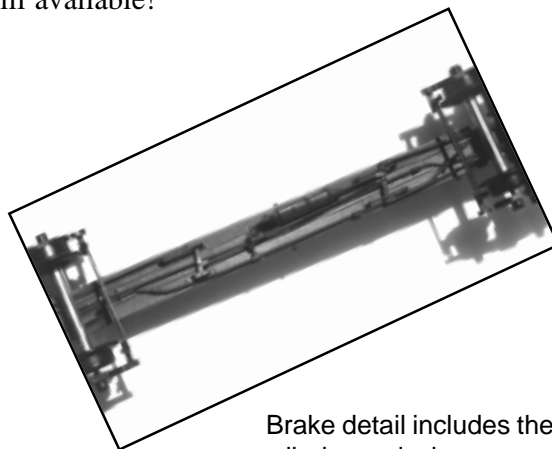

Brake detail includes the cylinder, rods, levers, and correct dual air lines - even on the 3-rail version!

Painted West Side Red

#15000 Log Car, On3	\$ 155.00
Log Car, On3, Six or more	\$ 125.00 ea.

**Sold
Direct Only**

B.T.S. Car Shops

**Sold
Direct Only**



Depressed-Center Flatcar

Designed to carry heavy and/or tall loads, the 40', 90-ton depressed-center flatcar is a unique car that will attract attention. It can be used in mainline freight service or as part of a work train with a piece of heavy equipment on top.

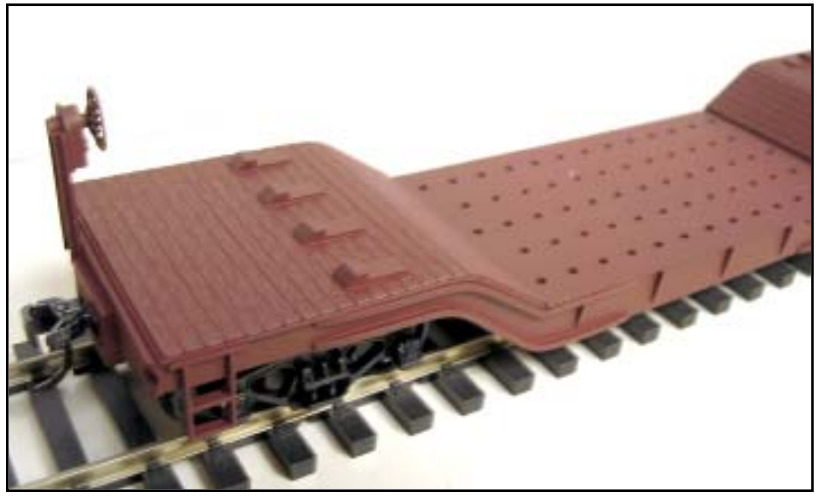

The unpainted kit consists of high-quality, no-odor urethane castings for the body. The kit features trucks, and brass & urethane brake components under both ends of the car. Less decals and couplers.

- #09209 S Scale
- #19209 O Scale

The crawler shown at the right is not included with the kit. Note that the ***B.T.S. Bell Crawlers*** will work well here!



**Sold
Direct Only**

Car Shops *B.T.S.*



PRR F39 Piggyback Flat Car

In March 1955, 200 of these 75' TOFC cars were put into service on the PRR. Designed to carry two of the then-current standard 35' trailers, they were initially in PRR red with white lettering. Later, they became Trailer Train cars, and as of 1990, over 100 were still in service.

The kit consists mostly of pewter castings which can be soldered together with low-temp solder and iron, or glued together with a strong ACC or epoxy. Car weight with trucks and couplers is 11.4 ounces. While it will handle a 34" radius curve, it will look better on larger.



Kadee couplers, SHS roller-bearing trucks, trailers, and decals are not included. The car is designed to use the SHS 35' trailers as shown in the photos. Limited edition - not always in stock.

#09203 S Scale PRR F39 Piggyback Flat Car

F89 Piggyback Flat Car

Introduced in the early 1960s, thousands of these long cars were built during the 60s and many are still in service. They have seen duty hauling trailers, containers, autos, pipes, and just about anything that is long!



The kit consists mostly of pewter castings which can be soldered together with low-temp solder and iron, or glued together with a strong ACC or epoxy. Due to its length, wide curves are required. Kadee couplers, SHS roller-bearing trucks, trailers, and decals are not included. The car is designed to use the American Models 40' trailers - SHS 35' trailer is shown in the photos.

#09200 S Scale F89 Piggyback Flat Car



B.T.S. Car Shops



PRR H21 Hopper

**Urethane kit includes
brass brake details.
Less trucks, couplers
and decals.**

#09204 S Scale



**Sold
Direct Only**

Car Shops *B.T.S.*

West Side Lumber Company

Narrow Gauge

Logging Flatcar

PRECISION
LASER-CUT

For most of this century, the West Side Lumber Company hauled huge logs from the California forests on simple, small flatcars. A most flexible piece of equipment, these cars ended up being the basis for boxcars, cabooses, and utility flatcars on the WSLCo.

The kit consists of laser-cut wood components designed for fast assembly. A single-piece frame, deck, and pre-drilled holes (well, most are!) allow the modeler to build this car in about an hour. Grandt Line nut-bolt-washer castings, custom decals, and brass brake components round out the kit.

Designed for Kadee HO couplers, the kit is less trucks and couplers.



WSLCo 24' Logging Flatcar

#09421 Sn3

#09422 Sn3 Five Pack

This kit will built into a standard flat or the equipment flat as shown above.

Standard Gauge Freight Cars

B.T.S. has acquired the Amity Star line of vintage S scale craftsman freight car kits. As time permits, we may be re-introducing many of these fine wood craftsman kits with upgraded details and laser-created parts. In addition, new kits are being created using both laser-cut wood and urethane. Both standard and narrow gauge projects are being developed. And consideration is being given to releasing many of these kits in HO and O scales.

Here is the list of the first S Scale cars that **will be available**:

#09000	S Scale	A.C.L. Watermelon Car
#09007	S Scale	Ma & Pa 35' Flat Car (Truss Rod) - In Stock
#09008	S Scale	Ma & Pa 35' Gondola (Truss Rod)
#09009	S Scale	Mower Lumber Co. Logging Flat Car



**Sold
Direct Only**

Car Shops **B.T.S.**

Rio Grande 01100-Series Wood Caboose



#09011
D&RGW 1100-Series Wood Caboose,
Standard Gauge, S Scale

S Scale at its Best!

From 1927 to the mid-1960's, the rear of many Rio Grande freight trains was guarded by this wood caboose. From the first day of service to retirement, about the only changes made to these cabs were cast-steel side frame trucks replacing the arch bar trucks, AB- replacing the K-brake systems, and the flying Rio Grande replacing the 'Scenic Line' herald.

This kit marks the first of a series of limited-edition cabooses coming from B.T.S. The #01100-series caboose is offered in a highly-detailed urethane kit and feature all the details from the K brake cylinder to the interior. The kits is less trucks.

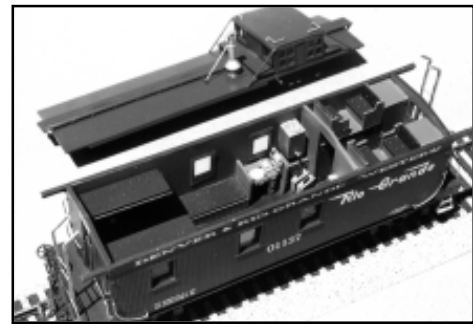

The problem with offering a caboose kit is that, with a very few exceptions, cabooses did not roam around, nor were there standard caboose designs. So deciding which caboose to make is a difficult challenge.

After spending over a year on the design stage, our first laser-cut caboose kit, the Sn3 E.B.T. Caboose, is nearing completion. Once this first cab is done, it is a relatively simple matter to use the same engineering methods and offer cabooses from other roads. Kits will include brake components, basic interior, tabbed construction, and accurate details. Watch for future releases, and let us know your favorite cab; we might just add it to the line!

Planned Releases

- #09104 E.B.T. Caboose, Sn3 (shown)
- #19104 E.B.T. Caboose, On3
- #09001 NKP Wood Caboose, #1000 Series, S
- #09004 Ma & Pa Wood Caboose, #2002, S
- #09006 Ma & Pa Wood Caboose, Ex-PRR ND, #2006, S
(All Brass Model)

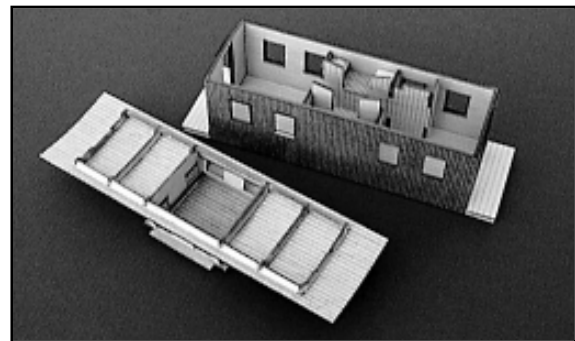

**PRECISION
LASER-CUT**

Some models will be offered in O and HO scales.

B.T.S. Posters and Signs

The following sets of full color posters are now available. Each set has 17 to 20 original color posters. Illustrations are much smaller than actual size. Many of these signs are offered in HO, S, and O scales, they have multiple uses in each scale. For example, the O scale version can be used as a billboard in HO scale. Or the HO version can become a handbill in O scale.

Turn of Century Women



#20906 HO Scale

Turn of Century Children



#20908 HO Scale

Business Variety I



#00926 S Scale
#10926 O Scale
#20926 HO Scale

Business Variety II



#00928 S Scale
#10928 O Scale
#20928 HO Scale

Americana I



#20910 HO Scale

Americana II



#20912 HO Scale

Franz Falk Brewery Billboard



#20916 22'-6" X 14'-6" HO
#20918 42'-6" X 27' HO

Warning Signs



#00930 S Scale
#10930 O Scale
#20930 HO Scale

General Store I



#00920 S Scale
#10920 O Scale
#20920 HO Scale

General Store II



#00922 S Scale
#10922 O Scale
#20922 HO Scale

General Store III



#00932 S Scale
#10932 O Scale
#20932 HO Scale

OSHA & Street Signs



#20914 HO Scale

All Scales Modeling Materials

#91100 Scale Screen Wire - 270-mesh per inch with 0.0016 diameter wire. Approximately 12 square inches.

#91101 Phos. Bronze Scale Screen Wire - Each pack contains approximately 12 square inches.

#91105 Scale Hose - Fine rubber that acts and feels right for a piece of rubber hose. 12" per package.

#91110 .0055 Magnet Wire - Ultra fine varnish-insulated, solderable, current-carrying magnet wire. This wire is perfect for exposed wiring jobs that need to have a "scale" conduit appearance. This wire can be painted with water-based paint. 3 ft/pack.

#20801 Metal Ridge Trim - Metal ridge trim is just like the ridge trim used on thousands of structures. It is formed of half-hard copper to a 12/12 pitch and it can be etched and/or painted. It is furnished in 8'-2" HO scale lengths allowing for a 2" overlap or more if desired. There are 6 pieces per package.

#91250 Miniature Lamp - Our lamps are only 1.5mm in size! They are designed for very long life. They accept only 1.5 volts for power. Exceeding this power level will destroy the lamp.

Figures

B.T.S.

Our HO figures are individually packed, unpainted brass workers for your layout or diorama. They are cast in realistic poses. S & O scale figures, and some HO animals, are white metal.



#20300 Tom #20302 Fred #20304 Bill

“Men at Work”

- #20300 Tom (axe swinger)
- #20302 Fred (pick axe user)
- #20304 Bill (holds a shovel well)
- #20306 Ted (standing around)
- #20308 John (with positionable arms)
- #20310 Jim (with positionable arms)
- #20312 Valdean (outstretched arms)
- #00312 Valdean (outstretched arms)
- #10312 Valdean (outstretched arms)
- #20314 Arley (lifting)
- #00314 Arley (lifting)
- #10314 Arley (lifting)
- #20316 Tyrel (walking)
- #20318 Joe (truck driver)
- #20320 Logan (kneeling worker)
- #20322 Art (lifting)
- #20324 Sam (hanging out)
- #20326 Chuck (carrying)
- #20328 Dan (lifting)
- #20330 Chris (kneeling worker)
- #20332 Clint (running bearded man)
- #20334 Festus (standing)

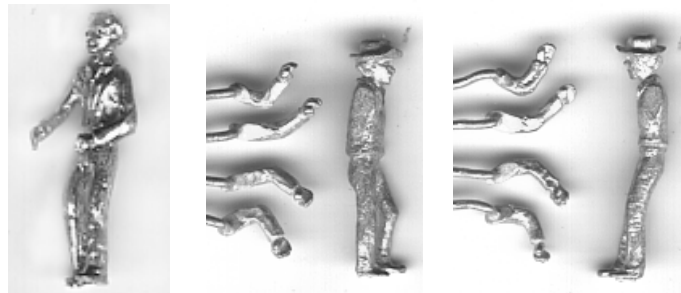

#20306 Ted #20308 John #20310 Jim

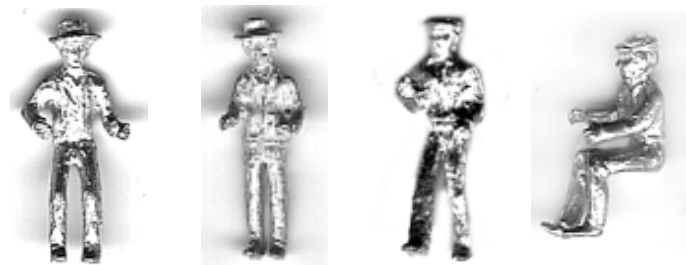

#20312 Valdean #20314 Arley #20316 Tyrel #20318 Joe



#20320 Logan #20322 Art #20324 Sam #20326 Chuck

Animals

- #20618 Rat Brass, Pkg (5)
- #20651 StandingDog Brass, Pkg (2)
- #20682 Skunk Pkg (2)
- #20736 Small Bird Pkg (4)
- #20750 Pigeon Pkg (6)
- #20752 Chicken Pkg (4)



#20328 Dan #20330 Chris #20332 Clint #20334 Festus

B.T.S. One-Niters

There are many structures that are more complex than a simple detail casting, and much less work than the easiest small building kit. They are the things that can be finished in just one evening of model building.

Oil Drum Rack

This is a laser-cut wood rack with two oil drums. Each package contains two rack/drum sets.



#03000 S Scale

#13000 O Scale

#23000 HO Scale

Cable Reels

This is a laser-cut, scale four foot diameter, wood cable reel perfect for gondola loads or simply sitting around the junk pile. Each package contains four reels.



#03003 S Scale

#13003 O Scale

#23003 HO Scale

Outhouse, Standard

Laser-cut wood outhouses of a simple standard design. Complete with the one hole inside, and the familiar crescent moon on the positionable door. Each package contains two outhouses.

#23004 HO Scale

#03004 S Scale

#13004 O Scale



Crossbucks, N&W

Laser-cut wood crossbucks with proper decals for the Norfolk And Western. Each package contains four crossbucks. The signboard, a rectangular piece that mounts below the crossbucks, can be left off as shown, or if used, we include the correct lettering for Virginia.

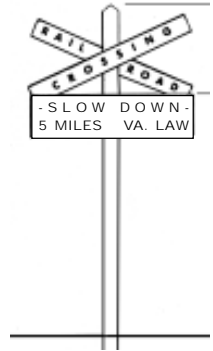

#03001 S Scale

#13001 O Scale

#23001 HO Scale

Crossbucks

Laser-cut wood crossbucks with decals. Each package contains four crossbucks. The signboard, a rectangular piece that mounts below the crossbucks, can be left off as shown, or if used, two signboards can be lettered 'look out for the cars' and two 'look out for the locomotive.'



#03002 S Scale

#13002 O Scale

#23002 HO Scale

Gents & Ladies Outhouses

Laser-cut wood outhouses with special designs in the door - the moon is the ladies and the star is for the gents. Seems years ago, few people could read, so inns used these symbols. The men's outhouse fell into disrepair faster, and since men are more likely to simply use the woods anyway, the gents outhouse was not always replaced. These are complete with the one hole inside and positionable door. Each package contains one of each style.

#23005 HO Scale

#03005 S Scale

#13005 O Scale



One-Niters

B.T.S.

Rocking Chair

Laser-cut rocker that is right for any front porch. Each package contains four rockers.

- #23006 HO Scale
- #03006 S Scale
- #13006 O Scale



Bench

Laser-cut wood bench is the type seen beside train station, in front of general stores, and just about any place where someone needs to park for a few minutes. . Each package contains two benches.

- #03012 S Scale
- #13012 O Scale
- #23012 HO Scale

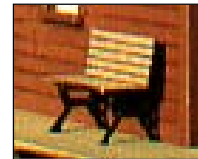

Clothes Line

Laser-cut clothes line posts could be found behind every house up until a few years ago. Each package contains four wood posts and line.

- #23007 HO Scale
- #03007 S Scale
- #13007 O Scale



Pallets

Laser-cut wood pallets look great either as new ones or abused ones. Each package contains 16 pallets.

- #03013 S Scale
- #13013 O Scale
- #23013 HO Scale

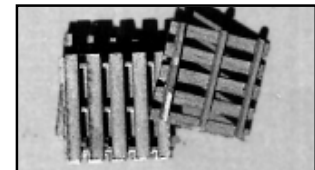

Upright Piano

Laser-cut wood is the only way to go to have a good-looking piano. Each package contains one piano and stool.

- #23008 HO Scale
- #03008 S Scale
- #13008 O Scale



Board Fence

Laser-cut wood provides individual board construction. Each package contains 90 scale feet of 6-foot high fence. (shown)

- #03014 S Scale
- #13014 O Scale
- #23014 HO Scale

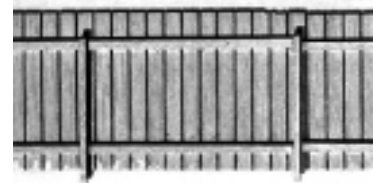

9" High Fence, 90 scale feet long

- #03019 S Scale
- #13019 O Scale
- #23019 HO Scale

Workbench

Laser-cut wood work bench that is perfect for just about any location where folks use tools. The bench is a scale eight feet long and thirty inches deep. Each package contains two benches.

- #03011 S Scale
- #13011 O Scale
- #23011 HO Scale



Wood Ladders

Laser-cut wood makes building these a snap. Each package contains four ladders - two different lengths.

- #03015 S Scale
- #13015 O Scale
- #23015 HO Scale



B.T.S. One-Niters

Wood Chairs, Straight

Laser-cut wood chairs look delicate and are easy to build. Each package contains four chairs.

- #03016 S Scale
- #13016 O Scale
- #23016 HO Scale



Wood Captain's Chairs

Laser-cut wood chairs look delicate and are easy to build. Each package contains four chairs.

- #03017 S Scale
- #13017 O Scale
- #23017 HO Scale



Logger (Picnic) Table

This simple table, complete with the 'X' shaped legs, was a common feature in the logger's dining area. And they are still in use in many places. Laser-cut wood, of course. Each package contains one table and two benches.

- #03018 S Scale
- #13018 O Scale
- #23018 HO Scale



Heavyduty Sawhorse

Ever see a shop without a bunch of these? Laser-cut wood, of course. Each package contains four sawhorses.

- #03020 S Scale
- #13020 O Scale
- #23020 HO Scale

Shingles



These shingles are high quality laser-cut items! They are self-adhesive, white non-coated paper stock and ready for painting or staining in any desired color. There are two sheets per package which will cover approximately 14 square inches of roof; TT shingles cover approximately 7 square inches.

The shingles are laser-cut in strips and peel away from the backing very easily, but be careful in handling them as they can adhere very quickly to each other. Lines are scribed on the roof cards to help align the shingles correctly. Just like with the real shingles, start at the bottom row and work up. Each succeeding layer of shingles should always overlap the lower layer and be offset about half a shingle width. Firmly press the shingles in place when finishing each section. Trim the shingles close to the end of the roof, and use the remainder from each row to start the next row up. Finish the roofs' left and right edges by trimming the shingles to within about one scale inch of the edge of the roof.

Stain the roof with the colors appropriate to your application. It is important to note that excessive use of solvents may cause some lifting of the shingles. Use solvents in moderation, and in accordance with their manufacturers' instructions. A good method is to spray a light coat of a base color on the shingles (for best results, use an airbrush), allow it to dry, then follow up with dry-brushing of a lighter shade to accent the shingles. A final dry brushing with powdered charcoal gives the roof the appearance of weathered cedar shingles.

TT	HO	O	S	
	#21000	#11000	#01000	Random Cedar Shingles
	#21004	#11004	#01004	Octagonal Shingles
	#21006	#11006	#01006	Diamond Shingles
	#21008	#11008	#01008	Sawtooth Shingles
#31010	#21010	#11010	#01010	Three-Tab Shingles
#31012	#21012	#11012	#01012	French Diamond Shingles

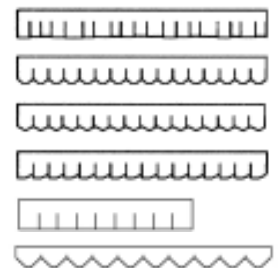

HO Scale FREIGHT CAR DETAIL PARTS

- 22600 Wood Floor, Athearn 52-Ft Gon, Laser Cut, Self Adhesive
- 22601 Wood Floor, Ertl 42-Ft Gon, Laser Cut, Self Adhesive
- 22603 Wood Deck, W&R SP&S/BN Bulkhead Flat, Laser Cut, Self Adhesive
- 22606 Wood Deck, Ertl 40-Ft Flatcar, Laser Cut, Self Adhesive , w/Stakes
- 22608 Wood Deck, P2K 53' Flatcar, Laser Cut, Self Adhesive
- 22609 Wood Deck, F&C E.B.T. Flatcar #73, Laser Cut
- 22610 Wood Deck, F&C E.B.T. Flatcar #100, Laser Cut

S Scale FREIGHT CAR DETAIL PARTS

- 02600 Wood Floor, A.M. 52-Ft Gon, Laser Cut, Self Adhesive
 - 02601 Wood Floor, A.F. 42-Ft Gon, Laser Cut, Self Adhesive
 - 02602 Roofwalk, A.M. 40' Boxcar, Laser Cut
 - 02603 Roofwalk, Crown 40' Reefer, Laser Cut
 - 02604 Roofwalk, PRS 40' Boxcar, Laser Cut
 - 02605 Roofwalk, PRS 40' Reefer, Laser Cut
 - 02606 Floor, PRS 40' Boxcar, Laser Cut, Self Adhesive
 - 02607 Floor, PRS 50' Double Door Boxcar, Laser Cut, Self Adhesive
 - 02608 Boxcar Interior, PRS 40' - 10'H, Laser Cut, Self Adhesive
 - 02609 Boxcar Interior, PRS 50' Double Door, Laser Cut, Self Adhesive
 - 02610 Boxcar Interior, PRS 40' Double Door, Laser Cut, Self Adhesive
- Note - Boxcar Interior kits include floor and four side walls.
- 02701 Tankcar Placard, WWII-Era, Color Sign (24)
 - 02800 Parlor Car Seat, D&RGW N.G., Urethane (4)
 - 02801 Panel Sides, A.M. Hopper, Urethane
 - 02712 Passenger 'Watch Your Step' Sign (24)

O Scale FREIGHT CAR DETAIL PARTS

- 12301 Westinghouse Air Brake Set
- 12302 Air Hoses (Flexible) Pkg (4)
- 12608 Wood Deck, Weaver Flat #U25XX, Self Adh.
- 12611 Wood Deck, Weaver War Gon #U17XX



02605



02602



02604



02600



02801



02608

S Scale Diesel Details

B.T.S.

S Scale Lost-Wax Brass Detail Castings

02001	Air Horn, Single Chime	Pkg (2)	\$ 2.75	02051	48" Pan-Top Fan	Pkg (2)	\$ 5.75
02002	Air Horn, Triple Chime	Pkg (1)	\$ 3.50	02052	Cab Shades	Pkg (2)	\$ 1.50
02003	Air Horn, Five Chime	Pkg (1)	\$ 3.50	02053	Front-Hanging Bell	Pkg (1)	\$ 3.75
02004	Exhaust Stacks	Pkg (2)	\$ 2.75	02054	Air Tank Piping	Set	\$ 4.25
02005	Dynamic Brake Fan, 48"	Pkg (1)	\$ 3.75	02055	Torpedo Tanks & Pipes	Set	\$ 12.00
02006	MU Hoses	Pkg(16)	\$ 4.75	02056	Winterization Hatch, 36 In.	Pkg (1)	\$ 4.50
02008	Number Boards	Pr.	\$ 2.75	02057	Pilot Steps	2 Pr	\$ 5.50
02010	Windshield Wipers	Pkg (4)	\$ 1.75	02058	Handbrake	Pkg (2)	\$ 2.50
02012	Steam Generator		\$ 3.00	02059	Wind Deflectors	Set	\$ 1.50
02013	Pyle Backup Light	Pkg (2)	\$ 1.75	02060	Fuel Filler/ Sight Glass	Set	\$ 3.75
02014	34" Flat-Top Fans	Pkg (4)	\$ 6.25	02061	Handrail Posts, GP-9 Ph III	Pkg(28)	\$ 10.75
02015	36" Cap-Top Fans	Pkg (4)	\$ 6.25	02062	Drop Steps	Pkg (2)	\$ 2.50
02016	Number Boards (PRR)	Pr.	\$ 2.75	02063	Steam Lines, Early	Pkg (2)	\$ 3.00
02017	Nose Door Light	Pkg (1)	\$ 1.75	02064	Steam Lines, Folding	Pkg (2)	\$ 3.00
02018	Door Handles	Pkg (6)	\$ 1.75	02065	MU Stands, Early	Pkg (4)	\$ 3.00
02019	Windshield Wipers	Pkg (4)	\$ 1.75	02066	Handrail Posts, Early GP	Pkg 28)	\$ 10.75
02020	Fuel Filler/Sight Glass	Pr.	\$ 2.50	02067	Winterization Hatch, 48in.	Pkg (1)	\$ 5.50
02022	Classification Lights	Pr.	\$ 1.50	02068	ALCo Truck Sideframe	Pkg (4)	\$ 33.50
02023	Winterization Hatch	Pkg (1)	\$ 4.75	02069	Cooling Coil	Pkg (1)	\$ 5.00
02024	Lift Rings, Nose	Pkg (4)	\$ 2.75	02070	Hand Rails	Set	\$ 5.00
02025	Lift Rings, Roof	Pkg(24)	\$ 4.75	02071	Lift Rings, Ends	Set	\$ 1.75
02026	Radio Antenna, Firecracker	Pkg (3)	\$ 2.75	02072	End Grab Irons	Set	\$ 1.25
02027	Radio Antenna, Sinclair	Pkg (2)	\$ 2.75	02073	Door Handles	Pkg (6)	\$ 1.75
02028	Barrel Headlight (SP/WP)	Pkg (1)	\$ 4.75	02074	Fuel Tank End Brace	Pkg (4)	\$ 1.75
02029	PRR Trainphone Posts	Pkg(14)	\$ 6.25	02075	Fuel Tank Detail	Set	\$ 3.75
02030	Speed Recorder	Pkg (2)	\$ 1.75	02076	P.R.R. Antenna Set	Set	\$ 11.75
02031	Plow Pilot	Pkg (1)	\$ 17.75	02077	Air Horn, Three Chime	Pkg (1)	\$ 3.50
02032	Winterization Hatch (CP,CN)	Pkg (1)	\$ 4.75	02078	Air Horn, Single Chime	Pkg (2)	\$ 2.75
02036	Twin Sealed Headlight	Pkg (2)	\$ 3.00	02079	Back-Up Light, Two Bulb	Pkg (1)	\$ 1.25
02037	Rerail Frog Standard	Pkg (2)	\$ 3.50	02080	Exhaust Stack	Pkg (1)	\$ 1.00
02038	Rerail Frog Batwing	Pkg (2)	\$ 3.50	02081	Windshield Wiper	Pkg (2)	\$ 1.75
02039	Roof Overflow Pipes	Pkg (4)	\$ 1.50	02082	Lift Rings/Bolts (Roof)	Pkg (6)	\$ 1.50
02040	Wagon Wheel Antenna	Pkg (1)	\$ 1.75	02083	Flag Holders	Pkg (2)	\$ 1.00
02041	Pyle Twin Signal Light	Pkg (2)	\$ 3.00	02084	Sand Filler Hatches	Pkg (4)	\$ 2.50
02042	Spark Arrestor, Non-Lifting	Pkg (2)	\$ 4.50	02085	Coupler Pads	Pkg (2)	\$ 4.50
02043	Spark Arrestor, Milw	Pkg (2)	\$ 6.00	02086	Coupler Draw Bar Housing	Pkg (2)	\$ 2.50
02044	Spark Arrestor, ATSF	Pkg (2)	\$ 4.50	02087	Dynamic Brake Panel	Pkg (1)	\$ 9.50
02045	Arm Rests	Pkg (2)	\$ 2.25	02088	Number Boards	Pkg (2)	\$ 4.00
02046	Diesel Grab Irons	Pkg (20)	\$ 5.50	02089	Battery Box Door	Pkg (2)	\$ 4.00
02047	Coupler Pad (F Dummy)	Pkg (2)	\$ 4.50	02090	Air Reservoir	Pkg (2)	\$ 5.00
02048	Spark Arrestor, Lifting	Pkg (2)	\$ 4.25	02091	Air Filter Vent	Pkg (3)	\$ 4.00
02049	MU Stand	Pkg (4)	\$ 4.25	02092	Blomberg Journal, FB	Pkg (8)	\$ 5.75
02050	MU Stand, High	Pkg (4)	\$ 4.25	02093	Blomberg Journal, RB	Pkg (8)	\$ 5.75

S Scale Lost-Wax Brass Detail Castings

Passenger Car Detail Parts

02401	Passenger Steam Lines	Pkg (2)	\$ 5.00
02402	Brake Set	3-Pc Set	\$ 6.00
02403	Steam Traps	Pr.	\$ 3.75
02405	Side Grab Irons		\$ 2.50
02406	End Grab Irons	3 Sets	\$ 3.75
02407	Brake Cyl,Torsion Bars	2 Pr	\$ 7.50
02408	Water Tank Heating Coil	Pkg (1)	\$ 3.75
02409	Brake Cylinder		\$ 5.00
02410	Distribution Valve		\$ 2.50
02411	Generator W/Bracket		\$ 3.00
02412	Air Reservoir Tank A		\$ 3.00
02413	Blow-Down Steam 'E'		\$ 4.00
02414	Bracket (8 Pc.)		\$ 2.00
02415	Dual Air Signal Line		\$ 2.50
02416	Slack Adjuster w/Pulley		\$ 4.00
02417	Steam Blow Down		\$ 4.00
02418	Water Tank		\$ 12.85
02419	Roof Ventilators (30 pc)		\$ 11.50
02420	Battery Box A		\$ 9.75
02421	Air Reservoir B		\$ 2.50
02422	Battery Box B		\$ 9.25
02423	End Stirrup		\$ 2.50
02424	Battery Box C		\$ 3.00
02425	Generator w/drive shaft		\$ 7.50
02426	Battery Box D		\$ 10.75
02427	Brake Lever on Bracket		\$ 4.00
02428	Pullman Air Tank A		\$ 2.00
02429	Pulley Handle		\$ 4.00
02431	Pullman Air Tank B		\$ 3.00
02432	Pullman Air Tank C		\$ 3.00
02433	Pullman Air Tank D		\$ 2.50
02434	Pullman Air Tank E		\$ 3.50
02435	Pullman Air Tank F		\$ 3.00
02436	Pullman Ice Box Control		\$ 3.50

02437	Pullman Truck Chain Bracket (8)		\$ 2.00
02438	Pullman Air Tank G		\$ 3.50
02439	Pullman Ice Box A		\$ 13.50
02440	Pullman Ice Box B		\$ 10.00
02441	Pullman Marker Lamp Bracket		\$ 1.50
02442	Pullman Vent		\$ 3.00
02443	Pullman Blow Down		\$ 3.00
02444	Pullman Brake Levers		\$ 2.00

Trucks

02902	D&RGW Caboose, RB	Pr	\$ 29.95
02903	PRR 4-wh Pass. 2D-P2	Pr	\$ 33.95
02904	EBT Vulcan, Sn3	Pr	\$ 9.95
	Less Wheelsets		
02905	Log Car Truck, S	Pr	\$ 27.50
02906	Log Car Truck, Sn3	Pr	\$ 27.50

Freight Car Detail Parts

02301	Westinghouse 'AB' Brake Set Set		\$ 7.25
02302	Air Hoses (Flexible)	Pkg (4)	\$ 4.25
02303	Brake Wheel, E.B.T.	Pkg (4)	Tba
02307	Hopper Door Latches	Pkg (4)	\$ 3.25
02308	Caboose Marker Lamps	Pkg (2)	\$ 3.00
02309	Perf'ed Stainless Material		\$ 2.00

Parts #02069-02091 Are For FA-1, FA-2, FA-1, FA-2; however, many will work on other ALCo locomotives. Parts #02001-02067 are for EMD E/F Units and Geeps



#02442



#02425



#02407

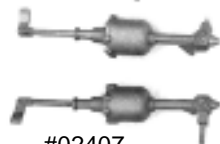

#02012



#02018



#02022



#02013



#02015



#02038



#02302



#02048

Parts shown approximately full size.

**Sold
Direct Only**

Small Steam **B.T.S.** S Scale Locomotive Kits

After several years of planning and effort, we have found an experienced locomotive builder willing to make **very small runs** of high-quality steam locomotives for us in S scale. Available in Kit Form or Semi-Kit with assembled mechanism, these small locos will be in high demand for those with limited layout space or those wishing to point to their locos proudly and say "I built it!"

These are made in small batches and may not always be in stock.



East Broad Top #6

Built by Baldwin in 1907 off their standard design, this was one of two **standard gauge locos** that handled interchange with the E.B.T. and PRR at Mt. Union until 1956. Similar to early switchers on other roads such as the PRR, Wabash, N&W, etc.

26" Minimum Radius



#06100 #6 Kit
#06200 #6 Semi-Kit

All *B.T.S.* locos feature:

Hollow Metal Boilers
Hollow Tender Tanks
Brass Tender Trucks
RP25, Code 110 Wheels
Mashima or Sagami Can Motor
Assembly using Epoxy, ACC,
or Low-Temp Solder

White Metal Cabs
Brass Loco and Tender Frames
Brass and White Metal Details
Northyard Gearing

32" Minimum Radius
Cab Interior & Crew Included

**These Locos are
built exclusively
for B.T.S.
in New Zealand
by JG Models**

Two Versions Offered: Kit Form and Semi-Kit with Assembled Mechanism.

B.T.S. *Small Steam*

**Sold
Direct Only**

S Scale Locomotive Kits

Consolidations



Ma & Pa #41

(and #42 - Pre-1929)

#41 and #42 were built by Baldwin in 1914; this class was the 'big power' on the road.

#06101 #41 Kit
#06201 #41 Semi-Kit
30" Minimum Radius

Ma & Pa #42

In 1929, #42 was equipped with an Elesco Feedwater system. Alligator crossheads and stepped steam dome make her different from #43.

#06104 #42 Kit
#06204 #42 Semi-Kit



Ma & Pa #43

Baldwin built it in 1925 off the same plan as #41-42 but she was equipped with an Elesco Feedwater system and Laird crossheads.

#06102 #43 Kit
#06202 #43 Semi-Kit



Baldwin 1905 2-8-0

The Baldwin 1905 2-8-0 was used by many railroads as their standard freight locomotive. On the Ma & Pa, four of these locos ran until the 1950s with #25-26 looking just about as they did when delivered.

#06103 BLW 2-8-0 Kit #06203 BLW 2-8-0 Semi-Kit



**Sold
Direct Only**

Small Steam **B.T.S.** **Sn3 & On3 Locomotives**

East Broad Top #12



You just cannot model the East Broad Top without having some mikados running around. This beautiful little 2-8-2 was built by Baldwin 80+ years ago, and still remains on the E.B.T. property handling some of the tourist trains in the summer.

B.T.S. is pleased to offer #12 as the first of several narrow gauge E.B.T. locomotives that will be done in S scale and O scale. The locomotives feature sprung drivers, cab interior, crew, and all the details in pewter and brass. Decals are in the box. These kits are made in small batches and may not always be in stock.

#06105 #12 Sn3 Kit

#06205 #12 Sn3 Semi-Kit

#16105 #12 On3 Kit

#16205 #12 On3 Semi-Kit

#16107 #12 On30 Kit

#16207 #12 On30 Semi-Kit



**Sold
Direct Only**

Small Steam **B.T.S.**

Sn3 & On3 Locomotives

East Broad Top #11



E.B.T.'s #11 was a 1908 Baldwin design and was the only 2-6-2 on the roster. It was the first loco on the E.B.T. to have a wide firebox. It vanished from the E.B.T. in April 1943 and no one knows where it ended up. Perhaps it went to scrap, or went on to serve in the Pacific theater for the US Navy.

The locomotive kits feature sprung drivers, cab interior, crew, and all the details in pewter and brass. Decals are in the box. And extra brass parts are included so you can build a slightly different version - a Pyle headlight & bracket, a generator, and a side-mounting whistle are in the box!

These kits are made in small batches and may not always be in stock.



#06106 #11 Sn3 Kit

#06206 #11 Sn3 Semi-Kit

B.T.S.

Diesel

Sold
Direct Only

S Scale Locomotive Kits



E.M.D. BL2

In 1948, the first of 59 branch line locos rolled out of the EMD shops. This loco was the link between the F-units and the first of the Geeps. With curved fenders, slab sides, and angled hoods, most folks either love or hate the beast!

According to the article published in one of the best modeling magazines, the *Mainline Modeler*, only nine railroads owned BL2s:

BAR	8	FEC	6
B&M	4	MP	8
C&EI	3	Monon	9
C&O	14	Rock Island	5
WM	2		



Our undecorated kit consists of five major castings with loads of details; the body is a one-piece casting with separate end castings, frame and fuel tank. Urethane fans, steps and drop steps are in the box along with handrail wire and laser-cut window 'glass.' In addition, lost-wax brass castings for fan housings, exhaust stacks, door handles, air horns, MU hoses, and air hoses are included.

This model is designed to use the trucks, gear towers, and motor from an American Models' FP unit.

Need BL2 Decals?

02702	BL2 Decal, B&M
02703	BL2 Decal, C&O
02704	BL2 Decal, Monon
02705	BL2 Decal, Rock Island
02706	BL2 Decal, Western Maryland

#06400 EMD BL2 Kit w/o mechanism





GP-30

S Scale Model variations of the GP-30 include:

#41000	Phase I Low Hood	\$779.00
#41001	Phase I Low Hood, Non-Dynamic	\$779.00
#41002	Phase I High Hood	\$789.00
#41003	Phase II Low Hood	\$779.00
#41004	Phase II Low Hood, Non-Dynamic	\$779.00
#41005	Phase II Low Hood, ALCO Trucks	\$779.00
#41006	Phase II Low Hood, ALCO Trucks, Non-DB	\$779.00
#41007	Phase II Low Hood, PRR Trainphone	\$819.00
#41008	U. P. B-Unit	\$789.00

Sold out!

Created in brass by
 OCS Precision Engineering Company of Korea.
 Limited Editions
 All models are delivered in natural brass.
 Custom Painting Available
 Sold exclusively by *B.T.S.*



Phase II Low Hood ALCO Trucks
 Used by the Milwaukee and GM&O

Some painted models are in stock for SOO, PRR, and Reading. Call for prices.

Sold Direct Only

1961 to Today!



Phase I Low Hood
 As used by: ATSF, B&O, C&O, CB&Q, D&RGW,
 Phelps Dodge, Reading, SAL, UP



Phase I Low Hood
 As used by: Alaska, ATSF, C&O, CB&Q, CP, C&EI,
 CGW, D&RGW, GN, KCS, SSW, AL, SP, UP

Nine Versions!



Phase I High Hood N&W



U. P. B-Unit Phase II Low Hood

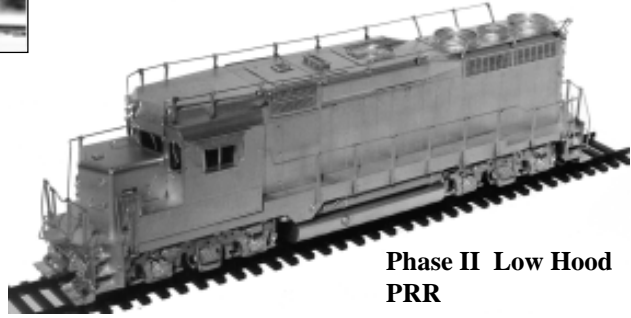

Phase II Low Hood PRR

B.T.S.

Extra Detail Kits

All **B.T.S.** kits contain the basic components needed to build a better-than-average scene. Some of our kits include additional details to make them even more special. But for the folks who just have to have it all, we offer some Extra Detail Kits that will really bring any scene to life.

#20772 Gas Pump Island Set Includes two pumps, water can, island, oil bottles, decals, signs and instructions.

#20774 Gas Station Detail Set Includes the parts in kit #20772, plus additional decals & details for a complete garage scene.

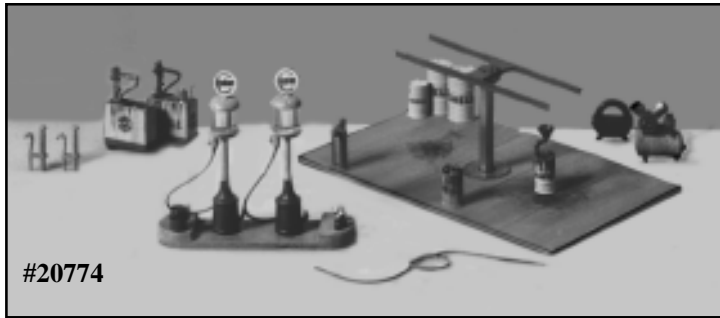

#20776 HO Engine House Details This kit contains over 50 HO details for both the exterior and the interior of a small engine house. Included in the kit is a stove, workbench, drill press, vise, shovel, pick ax, assorted tools, and a whole lot more. The parts are high-quality brass or white-metal castings, and laser-cut parts.



#00776 S Scale Engine House Details This kit contains over 40 details for both the exterior and the interior of a small engine house. The parts are high-quality castings and laser-cut parts including drums, crates, ladder, and sawhorses.

#20777 Logging Bunkhouse Details White metal and laser-cut HO parts to detail the interiors of our bunkhouse kit #27425. The kit includes parts to detail three bunkhouses each with a stove, table, chairs, bunks, etc.

#00805 S Scale Industrial Clutter This kit contains over 30 details for use around a small industry. The parts are high-quality castings and laser-cut parts including drums, crates, ladder, and pallets.

Some Random Thoughts...

Thanks for taking the time to look through our catalog, and for your continued support of our products. As full-time hobby manufacturers, we know that our main job is helping you enjoy our hobby. To do that, we are working hard to insure that the products we offer give you high quality, exceptional realism, hours of satisfaction, and an excellent value.

We have a lot of projects underway and we feel confident that, when they are announced, you will be as excited about them as we are now. One of our goals is to announce products just before they are ready to ship. In some cases, we have even had kits on the shelf prior to the announcement being made! Naturally, there are some things that are out of our control and these can often delay a project; but, we are working hard to reduce these potential delays by stockpiling some of the components that can cause outside delays. Your comments and suggestions are always welcome. Let us know what you want, and we will give it serious consideration. While we have a very aggressive project plan already developed, your ideas help keep us on track with your desires.

Diane and I attend the NMRA National Train Show, the National Narrow Gauge Convention, and several of the scale-specific conventions such as the National Association of S Gaugers and the National O Scale Convention. We look forward to meeting you there! Until then, keep in touch!

Bill Wade, Jr.

B.T.S. Copyright 2006
No part of this catalog may be reproduced
without written permission.



Craftsman Kits - Buildings And Structures

23000	Oil Drum Rack w/drums	Pkg (2)	8.95
23001	Crossbucks, N&W	Pkg (4)	8.95
23002	Crossbucks	Pkg (4)	8.95
23003	Cable Reel, 4' Dia.	Pkg (4)	6.95
23004	Outhouse, Standard	Pkg (2)	6.95
23005	Outhouse, Gents & Ladies	Pkg (1 ea)	6.95
23006	Rocking Chair	Pkg (4)	4.95
23007	Clothes Line	Pkg (2)	5.95
23008	Upright Piano	Pkg (1)	5.95
23011	Workbench	Pkg (2)	5.95
23012	Bench	Pkg (2)	4.95
23013	Pallets	Pkg (16)	4.95
23014	Board Fence, 6' high	90' Long	6.95
23015	Wood Ladders	Pkg (4)	7.95
23016	Wood Chairs, Straight	Pkg (4)	4.95
23017	Captain's Chair	Pkg (4)	4.95
23018	Logger (Picnic) Table	Pkg (1)	4.95
23019	Board Fence, 9' high	90' Long	9.95
23020	Sawhorse, Heavyduty	Pkg (4)	4.95
27103	Ballasted Deck Trestle	50' Long	24.95
27107	Team Track Office	12' x 14'	14.95
27110	The Shanty	24' x 44'	49.95
27111	Crossing Shanty	12' x 14'	14.95
27112	Tool Storage Shed	12' x 14'	13.95
27116	Utility Building Combo (1 ea. 27107, 27111, 27112)		39.95
27118	DT&I Std Station, Waiting Rm Rt	22' x 45'	49.95
27119	DT&I Std Station, Waiting Rm Lt	22' x 45'	49.95
27123	E.B.T. Saltillo Station	46' x 43'	59.95
27124	E.B.T. Coles Station	26' x 30'	29.95
27140	ET&WNC Covered Bridge, HOn3	18' x 118'	89.95
27142	Cheat Run Trestle, HO	13' x 27'	22.95
27143	Cheat Run Trestle, HOn3	12' x 27'	22.95
27162	NKP Green Springs Depot	24' x 52'	49.95
27225	Cabin Creek Small Store	12' x 20'	23.95
27226	Cabin Creek East End Grocery	18' x 34'	39.95
27227	Cabin Creek Greeley's Place	16' x 18'	18.95
27230	Cabin Creek Boot Repair	15' x 24'	23.95
27232	Cabin Creek Rural Church	24' X 56'	39.95
27233	Cabin Creek Post Office	16' X 26'	26.95
27234	Cabin Creek Singer Watch Repair	14' X 27'	26.95
27300	Shotgun House	17' x 52'	26.95
27301	Shotgun House, 3-Pack	17' x 52'	69.95
27304	Tobacco Barn	35' x 26'	29.95
27400	Flagstop Station	40' x 19'	34.95
27405	Junior's Shiner	30' x 22'	32.95
27410	Cleator's Gas	22' x 11'	29.95
27415	Best Auto Garage	28' x 30'	69.95
27420	Pritchard's Barn	36' x 18'	39.95
27425	Logging Bunkhouses	22' x 13'	29.95
27430	Slade's Assay Office	22' x 24'	24.95
27435	Willet's Supply	45' x 24'	49.95
27440	Babe's Diner	20' x 50'	49.95
27445	Coyote Draw Engine House, HOn3	18' x 50'	79.95
27450	Backwoods Engine House, HOn3	29' x 60'	59.95
27455	Buck's Dynamite Building	28' x 16'	31.95
27460	Red Eye Saloon	15' x 25'	21.95

Craftsman Kits - Buildings And Structures

27465	Kee's Chinese Laundry	22' x 25'	23.95
27470	Clegg's Cabin	13' x 20'	14.95
27475	WSLCo Camp Reynolds Cookhouse	50' x 36'	49.95
27480	Anderson Pulpwood Yard	24' x 40'	59.95
27500	New River Yard Freight House	27' x 80'	69.95
27501	New River Yard MoW Shed	22' x 29'	24.95
27502	Single-Stall Switcher Shed	21' x 70'	59.95
27503	New River Yard Handcar Shed	18' x 20'	29.95
27506	Loading Dock	16' x 85'	15.95
27507	N.G. Boxcar Shed	7' x 19'	19.95
27509	LCL Ramp	12' x 32'	16.95
27600	W&W Iams Station	44' x 28'	49.95
27603	W&W West Amity Station	24' x 22'	34.95
27700	#110 2nd St House	18' x 40'	39.95
27800	Wood Rick, Covered (Pkg 2)	9' x 41'	29.95
27801	Wood Rick, Uncovered (Pkg 2)	9' x 41'	19.95

Craftsman Kits - Rolling Stock

29401	CLC SP&M Ore Car	Temp Unavailable
29403	CLC CC 24' Box Car	Temp Unavailable
29405	CLC DSP&P Tiffany Reefer	Temp Unavailable
29407	CLC DSP&P Flat/Gon	Temp Unavailable
29409	CLC CC Excursion Car	Temp Unavailable
29411	CLC CC Covered Ore	Temp Unavailable
29413	CLC DSP&P, C&S Boxcar	Temp Unavailable
29415	CLC Russel Skeleton Log Car	Temp Unavailable
29417	CLC D&RG 1878 Standard Box Car	Temp Unavailable
29419	CLC RGS 24' Box Car	Temp Unavailable
29421	CLC West Side Standard Flat Car	13.95
29507	USMRR House Car	17.95
29508	USMRR House Car - Five Pack	82.95
29509	USMRR Flatcar, Nine Stake	16.95
29510	USMRR Flatcar, Nine Stake - Five Pack	78.95
29517	USMRR Flatcar, Five Stake	16.95
29521	USMRR Stock Car	tba

Craftsman Kits - Limited Edition

28106	Elliott & Sons Supply		139.95
28220	McCabe Sawdust Shed	23' x 28'	49.95
28225	McCabe Planing Shed	70' x 90'	195.00
28230	McCabe Drying Kiln	33' x 50'	59.95
28235	McCabe Log Dump		99.95
28240	McCabe Drying Platforms		19.95
28245	McCabe Pump House		49.95
28250	McCabe Tramway & Storage Yard	90' x 100'	99.95
28255	McCabe Tramway Extension		39.95
28260	McCabe Fire Hose Storage Sheds & Water Tank		39.95
28265	McCabe Camp Cars, Set I - Five Cars		165.00
28270	McCabe Camp Cars, Set II - Three Cars		135.00
28275	McCabe Fire Train - Three Cars		tba
28280	McCabe MoW Speeder, HO Std Gauge		139.95
28281	McCabe MoW Speeder, HOn3		139.95
28285	McCabe Company Office	19' x 36'	59.95
28295	McCabe Power House	60' x 54'	119.95
28300	McCabe Slatyfork Sawmill		289.95
29300	McCabe Bunk Car, Single Clerestory		36.95
29301	McCabe Bunk Car, Triple Clerestory		36.95

HO Scale

People			
20300	Tom	Brass	2.00
20302	Fred	Brass	2.00
20304	Bill	Brass	2.00
20306	Ted	Brass	2.00
20308	John - Posable Arms	Brass	2.50
20310	Jim - Posable Arms	Brass	2.50
20312	Valdean	Brass	2.00
20314	Arley	Brass	2.00
20316	Tyrel	Brass	2.00
20318	Joe	Brass	2.00
20320	Logan	Brass	2.00
20322	Art	Brass	2.00
20324	Sam	Brass	2.00
20326	Chuck	Brass	2.00
20328	Dan	Brass	2.00
20330	Chris	Brass	2.00
20332	Clint	Brass	2.00
20334	Festus	Brass	2.00
Animals			
20618	Rat	Brass, Pkg (5)	2.75
20651	Standing Dog	Brass, Pkg (2)	2.50
20682	Skunk	Pkg (2)	1.00
20736	Small Bird	Pkg (4)	1.00
20750	Pigeon	Pkg (6)	1.25
20752	Chicken	Pkg (4)	1.00
Details - Structures			
20624	Short Roof Vent	Pkg (4)	1.25
20634	Factory Roof Ventilator	Brass	1.45
20652	Drawer Pull	Brass, Pkg (2)	1.25
20656	Glass Insulator	Brass, Pkg (5)	2.75
20663	Candlestick Phone	Brass, Pkg (2)	2.00
20665	Watt Moreland Finial	Brass	1.00
20675	J L Mott Triplex Water Closet	Brass	4.50
20676	Stone Post	Pkg (2)	1.50
20681	Dock Bumper		1.00
20683	Steps		1.00
20685	Water Tower Finial	Pkg (2)	1.00
20687	Brick Pier		1.25
20689	Bottle Cap Sign		1.00
20691	Flat Top Smokejack		1.00
20710	File Cabinet		2.00
20719	Pot Belly Stove		1.75
20723	Pillar	Brass, Pkg (2)	1.00
20725	Fancy Finial		1.00
20727	Porch Post	Pkg (2)	1.00
20729	Warehouse Vent	Pkg (2)	1.00
20732	Ornate Lamp Post		1.00
20737	Door Latch Assembly	Brass	1.50
20740	Lightning Rod	Pkg (6)	1.00
20744	Flag Pole	Brass	1.25
20745	Spiral Lightning Rod w/ Glass Ball	Brass	1.25
20746	Door Handle Set	Brass	1.50
20747	Door Knob And Plate	Brass, Pkg (2)	1.50
20748	Pipe Elbow	Brass, Pkg (2)	1.50
20749	Valve	Brass, Pkg (2)	1.50
20751	Angle Insulator	Brass	1.00
20759	Bent Smokejack, 8'-6"	Pkg (2)	1.00
20761	T-Top Smoke Jack	Pkg (2)	1.00
20766	B&G Pillar		1.00
20776	Engine House Details		24.95
20780	Freight Door	Laser-Cut Wood	2.00
20781	Cone Top Smokejack	Pkg (2)	1.00
20784	Skylight	Laser-Cut Wood	2.50
20792	Mine Chute Assembly	Brass	4.00
20796	Mine Head Gear	Brass	2.00
20798	Smoke Jack	Pkg (2)	1.00
20800	Cellar Door	Metal/Laser-Cut Wood	2.50
20801	Metal Ridge Trim	8'-2" Scale, Pkg (6)	3.50
20803	Metal Ladder	2' X 20'	2.75
20804	Metal Ladder	18" X 20'	2.75
20806	Fire Hydrant	Pkg (4)	3.95
21000	Random Cedar Shingles	2 Sheets	4.00
21004	Octagonal Shingles	2 Sheets	4.00
21006	Diamond Shingles	2 Sheets	4.00
21008	Sawtooth Shingles	2 Sheets	4.00
21010	Three-Tab Shingles	2 Sheets	3.50
21012	French Diamond Shingles	2 Sheets	3.50
21014	Cedar Shake Shingles	2 Sheets	4.00
Details - Containers			
20612	Large Wooden Barrel		2.95
20614	Small Wooden Barrel	Brass, Pkg (2)	2.95
20620	Bottle 4 Styles	Brass, Pkg (8)	2.95
20628	Wooden Tub	Brass, Pkg (2)	3.50
20640	Metal Bucket	Brass, Pkg (2)	2.00
20642	Wooden Bucket	Brass, Pkg (2)	2.00
20653	Paint Can	Brass, Pkg (5)	2.75
20677	55 Gal Dirt Drum	Pkg (2)	1.25
20693	Pipe Drum	Pkg (2)	1.25
20720	Jug	Pkg (6)	1.00
20730	5 Gallon Can	Pkg (6)	1.00
20741	Junk Box	Pkg (3)	1.00
20742	Junk Drum	Pkg (3)	1.00
20757	Milk Can	Brass, Pkg (2)	1.75
20760	55 Gallon Drum	Pkg (4)	1.25
20797	Water Bottle	Pkg (6)	1.00
20799	Leaning Sack	Pkg (4)	1.00
Details - Tools And Equipment			
20354	Welding Cart		4.00
20601	Hand Oil Can	Brass, Pkg (5)	2.75
20609	Wire Spool	Pkg (2)	1.25
20613	Pliers	Brass, Pkg (5)	2.75
20622	Spade	Brass, Pkg (2)	2.50
20623	Anvil	Pkg (2)	2.50
20631	Short Screwdriver	Brass, Pkg (5)	2.75
20632	Fire Extinguisher	Brass, Pkg (2)	1.75
20637	Grease Gun	Brass, Pkg (5)	2.75
20639	Tool Set (Woodworking)	Brass	2.00
20643	Coal Scoop	Brass, Pkg (5)	2.75
20644	Rail Tong - Up	Brass, Pkg (2)	1.75
20647	Square Mallet	Brass, Pkg (5)	2.75
20654	Hand Truck	Brass	6.95

HO Scale

20664	Hand Drill	Brass, Pkg (5)	2.75		
20666	Set Works	Brass	1.50		
20667	Crow Bar	Brass, Pkg (5)	2.75		
20668	Wood Gouge	Brass, Pkg (5)	2.75		
20669	Spike Puller	Brass, Pkg (2)	2.00		
20692	Saw Mallet	Brass, Pkg (5)	2.75		
20694	File	Brass, Pkg (5)	2.75		
20696	Screw Driver	Brass, Pkg (5)	2.75		
20699	8-HP Stover Engine	Brass	9.95		
20700	1876 Challenge Pump	Brass	6.95		
20671	Tie Tong	Brass, Pkg (2)	2.00		
20672	Chisel	Brass, Pkg (5)	2.75		
20678	Sledge Hammer	Brass, Pkg (5)	2.75		
20680	Blow Torch	Brass, Pkg (2)	1.75		
20686	Wood Mallet	Brass, Pkg (5)	2.75		
20690	Solder Pot	Brass, Pkg (2)	2.00		
20703	Oil Drain Funnel	Pkg (2)	1.75		
20707	Lube Valve	Brass	1.25		
20708	Drill Press		2.75		
20709	Air Line Tee		1.25		
20722	Oil Can	Brass, Pkg (2)	1.75		
20726	Air Compressor Set	Brass	2.50		
20731	Vise	Brass	1.75		
20770	Tool Box		1.75		
20786	Oil Can W/Handle Tall	Brass, Pkg (2)	2.00		
20789	Tool Set	Pkg (4)	2.00		
20790	Pick Axe	Brass, Pkg (2)	2.00		
20791	Shovel	Brass, Pkg (2)	2.00		
	Details - Rolling Stock (Freight)				
20600	Air Hose	Pkg (2)	1.25		
20603	Westinghouse K Brake	Brass	1.25		
20616	Brake Wheel	Brass, Pkg (4)	2.00		
20617	C&S/RGS Reefer Hatch	Brass, Pkg (2)	2.00		
20621	C&S/RGS Reefer Hinge	Brass, Pkg (4)	1.50		
20627	C&S/RGS Coupler Pocket	Brass, Pkg (2)	2.00		
20629	C&S Box Door Guide	Pkg (2)	1.00		
20633	C&S Box Car Bolster	Pkg (2)	1.00		
20635	Log Car Bolster	Pkg (2)	1.00		
20646	C&S Deadwood	Brass, Pkg (2)	1.00		
20648	C&S Polling Pocket	Brass, Pkg (4)	1.00		
20661	Bearing Supports	Brass	1.50		
20662	CLC Stake Pocket	Brass, Pkg (6)	2.25		
20670	CLC Lift Ring	Brass, Pk (10)	1.50		
20674	Shackle Bar	Brass, Pkg (2)	2.00		
20688	Westside Brake Wheel	Brass, Pkg (2)	1.75		
20734	Tiffany Reefer Hinges	Brass	2.75		
20738	CLC Freight Car Hardware	Brass	5.95		
20794	1893 D&RG Reefer Car Vents	Pkg (2)	1.00		
22600	Wood Floor, Athearn 52-Ft Gon, Self Adh.		4.95		
22601	Wood Floor, Ertl 42-Ft Gon, Self Adh.		4.95		
22603	Wood Deck, W&R SP&S Bulkhead, Self Adh.		5.95		
22606	Wood Deck, Ertl 40-Ft Flatcar w/Stakes		5.95		
22608	Wood Deck, P2K 53' Flatcar, Self Adh.		5.95		
22609	Wood Deck, F&C E.B.T. Flatcar #73		3.00		
22610	Wood Deck, F&C E.B.T. Flatcar #100		3.00		
	Details - Food				
20701	Watermelon	Brass, Pkg (6)	1.25		
20702	Pumpkin	Pkg (6)	1.25		
20704	Gourd	Pkg (6)	1.25		
	Details - Pierce Arrow Automobile				
20695	Front Axle	Brass	5.95		
20697	Rear Axle	Brass	7.95		
20705	Exhaust Manifold	Brass	1.25		
20715	Gas Tank		1.50		
20716	Front Wheel & Tire	Brass, Pkg (2)	2.00		
20717	Steering Column		1.25		
20718	Rear Wheel & Tire	Brass, Pkg (2)	1.50		
20739	Hood		1.50		
20753	Bumper	Pkg (2)	1.50		
20754	Intake Manifold	Brass	1.25		
20755	Radiator		1.95		
20756	Engine	Brass	3.95		
20758	Automobile Transmission	Brass	1.50		
20763	Water Manifold		1.00		
20771	Seat		3.95		
20773	Magneto		1.00		
20775	Floor Assembly	Brass	3.95		
20778	Frame	Brass	2.95		
20779	Running Lamp Set	Brass	1.95		
20782	Shift Assembly		1.25		
20783	Battery Box		1.95		
20785	Hand Crank	Brass	1.00		
20787	Drive Shaft		1.00		
	Details - Gas Station				
20711	Hydraulic Automobile Hoist Set		4.50		
20712	Gas Tank Filler Vent Pipe	Brass	1.25		
20724	Hi-Boy Oil Container		2.25		
20728	Tube Testing Tank With Tire	Brass, Pkg (2)	1.75		
20762	Gas Pump - Filter Style		2.75		
20764	Gas Pump - Glass Style		3.50		
20765	Oil Tank With Valve	Brass	4.95		
20772	Gas Pump Island Set		8.95		
20774	Gas Station Detail Set (Includes Item #20772)		24.95		
20788	Fry Model 117 'Mae West' Gas Pump		3.95		
	Details - Logging				
20608	Loggers Lube Can	Brass, Pkg (2)	2.00		
20610	Broadax	Brass, Pkg (2)	1.75		
20611	Saw Anvil	Pkg (2)	1.00		
20615	Saw Swage	Brass, Pkg (5)	2.75		
20619	Small Tong	Brass, Pkg (5)	2.75		
20625	Large Tong	Brass, Pkg (4)	2.25		
20636	Peavey	Brass, Pkg (2)	2.00		
20638	Falling Ax	Brass, Pkg (2)	1.75		
20645	Pickaroon	Brass, Pkg (2)	1.75		
20649	Control Lever	Brass, Pkg (2)	2.00		
20655	Large Band Wheel	Brass	3.00		
20657	Bandsaw Drive Wheel		1.50		
20658	Knife Switch	Brass, Pkg (5)	2.75		
20659	Headblock	Brass	1.50		
20673	Claw Bar	Brass, Pkg (2)	2.00		
20777	Logging Bunkhouse Details		12.95		

HO Scale

Details - Miscellaneous			
20599	Tombstone Set	Pkg (13)	1.50
20602	Lunch Box	Brass, Pkg (2)	1.50
20605	Tin Plate	Brass, Pkg (5)	2.75
20607	Frying Pan	Brass, Pkg (5)	2.75
20626	Straw Broom	Pkg (2)	1.50
20630	Coffee Cup	Brass, Pkg (6)	2.50
20660	Pallet		1.25
20679	Suitcase	Pkg (5)	1.25
20684	Coffee Pot	Brass, Pkg (2)	1.75
20706	Rear Axle (Oldsmobile)	Brass	1.25
20714	Hand Lantern	Brass, Pkg (2)	2.50
20733	Spittoon	Pkg (5)	1.25
20793	Push Broom	Brass, Pkg (2)	1.25
Signs / Posters / Decals			
20906	Color Poster Set, Turn Of Century Women		1.95
20908	Color Poster Set, Turn Of Century Children		1.95
20910	Color Poster Set, Americana I		1.95
20912	Color Poster Set, Americana II		1.95
20914	Color OSHA And Street Signs		1.00
20916	Franz Falk Brewery Billboard	22'-6" x 14'-6"	1.00
20918	Franz Falk Brewery Billboard	42'-6" x 27'	2.95
20920	Color Poster Set, General Store I		2.45
20922	Color Poster Set, General Store II		1.95
20926	Color Poster Set, Business Variety I		1.95
20928	Color Poster Set, Business Variety II		1.95
20930	Warning Signs		1.00
20932	Color Poster Set, General Store III		1.95
Limited Edition Brass Models			
28504	Assembled Brass Logging Wagon		39.95
Detail Clusters			
20000	Tire, Grinder, 30-Gal Drum		2.00
20001	5 Standing Bags	Pkg (2)	2.00
20002	20-Gal Drum, Concrete Block, Radiator	Pkg (2)	2.00
20003	Crushed Crate, Junk Drum, Tire		2.00
20004	30-Gal Drums, Beer Keg, Wheel		2.00
20005	Pallet, Junk Box, Bag, Barrel		2.00
20006	Junk Drum, Barrel, Tire, Concrete Block		2.50
20007	Light Reflector	Pkg (3)	1.25
20008	Wheel Pile	Pkg (2)	2.00
20009	3 55-Gal Drums	Pkg (2)	2.00
20010	Air Comp, 55-Gal Drum, Grinder		2.50
20011	Trash Can w/Trash, Barrel, Engine		2.00
20012	3 Stacked Beer Kegs	Pkg (2)	1.50
20013	5-Gal Stacked Can, Water Bottle	Pkg (2)	1.50
20014	5-Gal Strewn Can	Pkg (2)	1.50
20015	Loco Rod, Tire, Engine Holder		2.00
20016	Roof Vents, Tire, 30-Gal Drum, Warehouse Vent		2.00
20017	Junk Drum, Trash Can w/Trash, Wood Junk Drum		2.00
20018	2 Barrels, 2 Drums, 2 Milk Cans		2.00
20019	3 Sacks	Pkg (3)	1.50
20020	Radiator, Strewn Junk		2.00
20021	Stacked Crates with Lantern and Bucket		2.00
20022	55-Gal Drum and Box	Pkg (2)	2.00
20023	Tire Stack	Pkg (3)	1.50
20024	Wooden Crates	Pkg (2)	1.50
20025	30-Gal Drums, 2 Barrels		2.50

20026	2 Crates, 1 Barrel		1.50
20028	Cement Bags	Pkg (3)	1.50
20029	5 Stacked Boxes	Pkg (2)	1.50
20030	3 Stacked Crates	Pkg (2)	1.50
20031	Board on Drums with Junk		1.50
20032	Barrel, 2 Crates, Pigeon		1.50
20033	Large Jug, 2 Crates		1.50
20034	Small Jug, 2 Crates	Pkg (2)	1.50
20035	Junk Shelf		1.50
20036	Pallet Stack	Pkg (2)	1.50
20037	Barrel, 3 Jugs, Bucket		1.50
20038	4 Small Crates	Pkg (2)	1.50

S Scale

Craftsman Kits - Buildings And Structures			
03000	Oil Drum Rack w/drums	Pkg(2)	11.95
03001	Crossbucks, N&W	Pkg (4)	11.95
03002	Crossbucks	Pkg (4)	11.95
03003	Cable Reel, 4' Dia.	Pkg (4)	9.95
03004	Outhouse, Standard	Pkg (2)	7.95
03005	Outhouse, Gents & Ladies	Pkg (1 ea)	7.95
03006	Rocking Chair	Pkg (4)	5.95
03007	Clothes Line	Pkg (2)	6.95
03008	Upright Piano	Pkg (1)	6.95
03011	Workbench	Pkg (2)	6.95
03012	Bench	Pkg (2)	6.50
03013	Pallets	Pkg (16)	5.95
03014	Board Fence, 6' high	90' Long	7.95
03015	Wood Ladders	Pkg (4)	8.95
03016	Wood Chairs, Straight	Pkg (4)	5.95
03017	Captain's Chair	Pkg (4)	6.50
03018	Logger (Picnic) Table	Pkg (1)	6.50
03019	Board Fence, 9' high	90' Long	12.95
03020	Sawhorse, Heavyduty	Pkg (4)	6.50
05005	Instrument House	7' x 9'	24.95
07103	Ballasted Deck Trestle, 50'	16' x 50'	29.95
07105	Stock Pens	43' x 61'	49.95
07107	Team Track Office	12' x 14'	19.95
07110	The Shanty	24' x 44'	69.95
07111	Crossing Shanty	12' x 14'	19.95
07112	Tool Storage Shed	12' x 14'	18.95
07113	JD Interlocking Tower	27' x 32'	69.95
07114	Cabin Creek Water Tank	18' x 22'	49.95
07122	E.B.T. Three Springs Station	44' x 33'	59.95
07123	E.B.T. Saltillo Station	46' x 38'	89.95
07124	E.B.T. Coles Station	30' x 26'	34.95
07127	E.B.T. Orbisonia Station	64' x 75'	350.00
07140	ET&WNC Covered Bridge, Sn3	18' x 118'	129.95
07141	Covered Bridge, Standard Gauge	22' x 118'	139.95
07142	Cheat Run Trestle, S	13' x 27'	27.95
07143	Cheat Run Trestle, Sn3	12' x 27'	27.95
07162	NKP Green Springs Depot	24' x 52'	89.95
07171	Laurel Brook Station	12' x 15'	15.95

S Scale

Craftsman Kits - Buildings And Structures

07225	Cabin Creek Small Store	12' x 20'	29.95
07226	Cabin Creek East End Grocery	18' x 34'	69.95
07227	Cabin Creek Greeley's Place	16' x 18'	23.95
07230	Cabin Creek Boot Repair	15' X 24'	28.95
07232	Cabin Creek Rural Church	24' X 56'	59.95
07233	Cabin Creek Post Office	16' X 26'	32.95
07234	Cabin Creek Singer Watch Repair	14' X 27'	36.95
07300	Shotgun House	17' x 52'	36.95
07304	Tobacco Barn	35' x 26'	36.95
07400	Flagstop Station	40' x 19'	39.95
07405	Junior's Shiner	30' x 22'	44.95
07420	Pritchard's Barn	36' x 18'	59.95
07425	Logging Bunkhouses	22' x 13'	34.95
07435	Willet's Supply	45' x 24'	69.95
07450	McCabe's Engine House	29' x 60'	69.95
07460	Red Eye Saloon	15' x 25'	28.95
07465	Kee's Chinese Laundry	22' x 25'	29.95
07470	Clegg's Cabin	13' x 20'	19.95
07480	Anderson Pulpwood Yard	24' x 40'	74.95
07500	New River Yard Freight House	20' x 74'	119.95
07501	New River Yard MoW Shed	22' x 29'	34.95
07502	Single-Stall Switcher Shed	21' x 70'	99.95
07503	New River Yard Handcar Shed	18' x 20'	36.95
07506	Loading Dock	16' x 85'	24.95
07507	N.G. Boxcar Storage Shed	7' x 19'	27.95
07509	LCL Ramp	12' x 32'	19.95
07700	#110 2nd St House	18' x 40'	44.95

Craftsman Kits - Limited Edition

08105	Cabin Creek Coal Tipple - Lighted		429.95
08106	Elliott & Sons Supply	40' x 60'	199.95
08115	Two-Stall Engine House	41' x 101'	189.95
08220	McCabe Sawdust Shed	23' x 28'	79.95
08230	McCabe Drying Kiln	33' x 50'	99.95
08235	McCabe Log Dump		139.95
08240	McCabe Drying Platforms		29.95
08250	McCabe Tramway & Storage Yard	90' x 100'	144.95
08255	McCabe Tramway Extension		59.95
08260	McCabe Fire Hose Storage Sheds & Water Tank		59.95
08285	McCabe Company Office	18' x 36'	99.95
08606	Bell Crawler, Model 39		89.95
09300	McCabe Bunk Car, Single Clerestory		59.95

Craftsman Kits - Rolling Stock

08280	McCabe Speeder, S Standard Gauge		tba
08281	McCabe Speeder, Sn3		tba
08282	Lobster Speeder, Sn2		139.95
08283	Big Sandy Speeder, Sn42		139.95
09007	Ma & Pa 35' Flat Car		29.95
09011	D&RGW Wood Caboose, S Std Gauge		74.95
09421	WSLCo. 24' Logging Flat Car, Sn3		16.95
09422	WSLCo. 24' Logging Flat Car, Sn3 - 5 Pk		79.95
09104	E.B.T. Caboose, Sn3		tba
09106	E.B.T. Tank Car, #116, Sn3		164.95
09200	TT F89F 89' Piggyback Flat Car		99.95
09203	F39 75' Piggyback Flat Car		89.95
09204	PRR H21a Sawtooth Hopper		79.95
09209	Depressed Center Flat Car		59.95

Details - Structures

00358	Bent Smokejack, 6'		1.25
00470	Smoke Jack		1.50
00687	Brick Pier		1.50
00689	Bottle Cap Sign		1.25
00735	Finial		1.00
00740	Lightning Rod	Pkg (4)	1.25
00746	Door Handle Set	Brass	1.75
00747	Door Knob And Plate	Brass, Pkg (2)	1.75
00776	Engine House Details		19.95
00780	Freight Door	Laser-Cut	3.00
00784	Skylight	Laser-Cut	3.00
00802	Snow Eagles	Pkg (60)	3.50
00805	Industrial Clutter		14.95
00806	Fire Hydrant	Pkg (3)	4.95
01000	Random Cedar Shingles	2 Sheets	4.00
01004	Octagonal Shingles	2 Sheets	4.00
01006	Diamond Shingles	2 Sheets	4.00
01008	Sawtooth Shingles	2 Sheets	4.00
01010	Three-Tab Shingles	2 Sheets	3.50
01012	French Diamond Shingles	2 Sheets	3.50
01014	Cedar Shake Shingles	2 Sheets	4.00

People

00312	Valdean		2.25
00314	Arley		2.25

Details - Containers

00720	Jug	Pkg (4)	1.25
00741	Junk Box		1.00
00742	Junk Drum	Pkg (2)	1.25
00757	Milk Can	Pkg (2)	2.00
00760	55 Gallon Drum	Pkg (2)	1.25
00767	Large Crate	Laser-Cut	1.75
00768	Medium Crate	Laser-Cut	1.75
00769	Small Crate	Laser-Cut	1.75
00797	Water Bottle	Pkg (4)	1.00
00799	Leaning Sack	Pkg (3)	1.25

Tools

00610	Broadax	Pkg (2)	3.75
00645	Pickaroon	Pkg (2)	3.75

Details - Food

00701	Watermelon	Pkg (5)	1.25
00702	Pumpkins	Pkg (5)	1.25
00704	Gourd	Pkg (4)	1.25
00713	Fruit Box	Pkg (2)	1.25

Signs / Posters / Decals

00920	Color Poster Set, General Store I		2.25
00922	Color Poster Set, General Store II		3.50
00926	Color Poster Set, Business Variety I		2.25
00928	Color Poster Set, Business Variety II		2.25
00930	Warning Signs		1.50
00932	Color Poster Set General Store III		2.25
02702	BL2 Decal, B&M		11.95
02703	BL2 Decal, C&O		7.95
02704	BL2 Decal, Monon		7.95
02705	BL2 Decal, Rock Island		7.95
02706	BL2 Decal, Western Maryland		6.95

S Scale

Laser-Cut Freight Car Details			Laser-Cut Freight Car Details		
02600	Wood Floor, A.M. 52-Ft Gon, Self Adhesive	8.95	02608	Boxcar Interior, PRS 40'-10'H, Self Adhesive	13.95
02601	Wood Floor, A.F. 42-Ft Gon, Self Adhesive	8.95	02609	Boxcar Interior, PRS 50' DD, Self Adhesive	15.95
02602	Roofwalk, A.M. 40' Boxcar	4.95	02610	Boxcar Interior, PRS 40' DD, Self Adhesive	15.95
02603	Roofwalk, Crown 40' Reefer	4.95	Note - Boxcar Interior kits include floor and four side walls.		
02604	Roofwalk, PRS 40' Boxcar	4.95	Freight Car Details		
02605	Roofwalk, PRS 40' Reefer	3.50	02701	Tankcar Placard, WWII-Era, Color Sign (24)	5.00
02606	Floor, PRS 40' Boxcar, Self Adhesive	8.95	02800	Parlor Car Seat, D&RGW N.G., Urethane (4)	2.25
02607	Floor, PRS 50' DD Boxcar, Self Adhesive	8.95	02801	Panel Sides, A.M. Hopper, Urethane	9.95
			02712	Passenger 'Watch Your Step' Sign (24)	5.00

Steam Locomotive Kits

#26110	W&W #1-6 HOn3	2-6-0	Kit	\$ tba
#26111	W&W #7 HOn3	2-6-0	Kit	\$ tba
#06100	E.B.T. #6	0-6-0	Kit	\$ 549.95
#06200	E.B.T. #6	0-6-0	Semi-Kit	\$ 699.95
#06101	M&Pa #41	2-8-0	Kit	\$ 599.95
#06201	M&Pa #41	2-8-0	Semi-Kit	\$ 799.95
#06104	M&Pa #42	2-8-0	Kit	\$ 629.95
#06204	M&Pa #42	2-8-0	Semi-Kit	\$ 829.95
#06102	M&Pa #43	2-8-0	Kit	\$ 629.95
#06202	M&Pa #43	2-8-0	Semi-Kit	\$ 829.95
#06103	BLW Light 1905	2-8-0	Kit	\$ tba
#06203	BLW Light 1905	2-8-0	Semi-Kit	\$ tba
#06105	E.B.T. #12 Sn3	2-8-2	Kit	\$ 629.95
#06205	E.B.T. #12 Sn3	2-8-2	Semi-Kit	\$ 849.95
#06106	E.B.T. #11 Sn3	2-6-2	Kit	\$ 599.95
#06206	E.B.T. #11 Sn3	2-6-2	Semi-Kit	\$ 829.95
#06108	PRR H-8/9	2-8-0	Kit	\$ tba
#06208	PRR H-8/9	2-8-0	Semi-Kit	\$ tba
#16105	E.B.T. #12 On3	2-8-2	Kit	\$ 799.95
#16205	E.B.T. #12 On3	2-8-2	Semi-Kit	\$ 999.95
#16107	E.B.T. #12 On30	2-8-2	Kit	\$ 799.95
#16207	E.B.T. #12 On30	2-8-2	Semi-Kit	\$ 999.95
#16115	Wabash G1	2-6-2	Semi-Kit	\$ tba

All B.T.S. steam locos feature:

Hollow Metal or Urethane Boilers

Brass Loco and Tender Frames

Assembly using Epoxy, ACC, or Low-Temp Solder

White Metal or Urethane Cabs

Semi-Kit features Assembled Mechanism.

Available Direct from B.T.S. Only

These loco kits are created in batches - they may be out of stock occasionally.

Diesel Locomotives - All are S scale unless Specified

#06400	BL2 w/o Mechanism	Kit	\$ TOS
	Urethane body & frame with brass and urethane details.		

Greenbrier Railroad Models

#41000	GP-30 Ph I Low Hood	\$ 779.00
#41002	GP-30 Ph I High Hood	\$ 789.00
#41008	GP-30 U.P. B-Unit	\$ 789.00

Greenbrier Railroad Models' GP-30s are unpainted, Korean brass imports. Only a few of each version are still available! Custom painting is available.

O Scale

Note - Structure Footprints are in Scale Feet

Craftsman Kits - Buildings And Structures

13000	Oil Drum Rack w/drums	Pkg (2)	14.95
13001	Crossbucks, N&W	Pkg (4)	14.95
13002	Crossbucks	Pkg (4)	14.95
13003	Cable Reel, 4' Dia.	Pkg (4)	11.95
13004	Outhouse, Standard	Pkg (2)	8.95
13005	Outhouse, Gents & Ladies	Pkg (1 ea)	8.95
13006	Rocking Chair	Pkg (4)	6.95
13007	Clothes Line	Pkg (2)	7.95
13008	Upright Piano	Pkg (1)	7.95
13011	Workbench	Pkg (2)	7.95
13012	Bench	Pkg (2)	7.95
13013	Pallets	Pkg (16)	7.95
13014	Board Fence, 6' high	90' Long	8.95
13015	Wood Ladders	Pkg (4)	9.95
13016	Wood Chairs, Straight	Pkg (4)	6.95
13017	Captain's Chair	Pkg (4)	8.50
13018	Logger (Picnic) Table	Pkg (1)	7.50
13019	Board Fence, 9' high	90' Long	15.95
13020	Sawhorse, Heavyduty	Pkg (4)	7.50
17103	Ballasted Deck Trestle, 50'	16' x 50'	39.95
17105	Stock Pens	43' x 61'	69.95
17107	Team Track Office	12' x 14'	22.95
17110	The Shanty	24' x 44'	89.95
17111	Crossing Shanty	12' x 14'	22.95
17112	Tool Storage Shed	12' x 14'	21.95
17122	E.B.T. Three Springs Station	44' x 33'	84.95
17123	E.B.T. Saltillo Station	46' x 38'	119.95
17124	E.B.T. Coles Station	30' x 26'	49.95
17127	E.B.T. Orbisonia Station	64' x 75'	400.00
17140	ET&WNC Covered Bridge, On3/30	18' x 118'	tba
17142	Cheat Run Trestle, Std Gauge	13' x 27'	37.95
17143	Cheat Run Trestle, On3/30	12' x 27'	37.95
17225	Cabin Creek Small Store	12' x 20'	36.95
17226	Cabin Creek East End Grocery	18' x 34'	89.95
17227	Cabin Creek Greeley's Place	16' x 18'	28.95
17230	Cabin Creek Boot Repair	15' x 24'	36.95
17232	Cabin Creek Rural Church	24' X 56'	74.95
17233	Cabin Creek Post Office	16' x 26'	46.95
17234	Cabin Creek Singer Watch Repair	14' X 27'	46.95
17300	Shotgun House	17' x 52'	49.95
17304	Tobacco Barn	35' x 26'	47.95
17400	Flagstop Station	40' x 19'	49.95
17405	Junior's Shiner	30' x 22'	49.95
17420	Pritchard's Barn	36' x 18'	79.95
17425	Logging Bunkhouses	22' x 13'	39.95
17435	Willet's Supply	45' x 24'	89.95
17460	Red Eye Saloon	15' x 25'	34.95
17465	Kee's Chinese Laundry	22' x 25'	36.95
17470	Clegg's Cabin	13' x 20'	26.95
17480	Anderson Pulpwood Yard	24' x 40'	89.95
17500	New River Yard Freight House	20' x 74'	169.95
17501	New River Yard MoW Shed	22' x 29'	49.95
17502	Single-Stall Switcher Shed	21' x 70'	139.95
17503	New River Yard Handcar Shed	18' x 20'	49.95
17506	Loading Dock	16' x 85'	29.95
17507	N.G. Boxcar Storage Shed	7' x 19'	36.95
17509	LCL Ramp	12' x 32'	22.95
17700	#110 2nd St House	18' x 40'	59.95
17800	Wood Rick, Covered (Pkg 2)	9' x 41'	54.95
17801	Wood Rick, Uncovered (Pkg 2)	9' x 41'	34.95

Freight Cars

15000	WSLCo Skeleton Log Car, On3, Brass	155.00
19101	E.B.T. Steel Flat Car, #100-series, On3, Brass	tba
19102	E.B.T. Steel 3-Bay 35-Ton Hopper, On3, Urethane	tba
19103	E.B.T. Steel 3-Bay 40-Ton Hopper, On3, Urethane	tba
19104	E.B.T. Caboose, On3, Laser-Cut Wood	tba
19106	E.B.T. Tank Car, #116, On3, Brass	tba
19209	Depressed-Center Flatcar, Urethane	89.95
19210	Water Car (Truss Rod), Laser-Cut Wood	tba
19211	Crane Tender, Urethane	tba
19212	Work Flat Car (Truss Rod), Laser-Cut Wood	tba
19213	Materials Flat Car (Truss Rod), Laser-Cut Wood	tba
19214	Boom Car (Truss Rod), Laser-Cut Wood	tba
19215	Tool Car (Truss Rod), Laser-Cut Wood	tba
19216	Bunk Car (Truss Rod), Laser-Cut Wood	tba
19217	Kitchen Car (Truss Rod), Laser-Cut Wood	tba
19507	USMRR House Car	tba
19509	USMRR Flatcar, Nine Stake	tba
19517	USMRR Flatcar, Five Stake	tba
19521	USMRR Stock Car	tba

Craftsman Kits - Limited Edition

18105	Cabin Creek Coal Tipple, Lighted	549.95
18106	Elliott & Sons Supply	40' x 60' 229.95
18115	Two-Stall Engine House	41' x 101' tba
18240	McCabe Drying Platforms (4)	39.95
18250	McCabe Tramway & Storage Yard	199.95
18255	McCabe Tramway Extension	69.95
18260	McCabe Fire Hose Storage Sheds & Water Tank	79.95
18285	McCabe Company Office	18' x 36' 129.95
18295	McCabe Power House	60' x 54' 199.95
18300	McCabe Slatyfork Sawmill	850.00
19300	McCabe Bunk Car, Single Clerestory	74.95
19301	McCabe Bunk Car, Triple Clerestory	74.95
19302	McCabe Blacksmith Car	74.95
19303	McCabe Office Car	74.95
19304	McCabe Shower Car	74.95
19306	McCabe Cookhouse Camp Car	94.95
19307	McCabe Dining Camp Car	84.95
18280	McCabe Speeder, O Standard Gauge	tba
18281	McCabe Speeder, On3	229.95
18283	McCabe Speeder, On30	229.95
18505	Bridge Crane, Painted Brass Model	119.95
18600	Bell Crawler, Model 36, w/ Blade	129.95
18601	Bell Crawler, Model 36, w/o Blade	109.95
18604	Bell Crawler, Model 36, w/ Logging Arch	159.95

B.T.S.
Better Than Scratch!

P O Box 856
Elkins, WV 26241-0856
E-Mail: bill@btsrr.com

Phone: 304-637-4510
Fax: 304-637-4506
Web: www.btsrr.com

O Scale

Note - Structure Footprints are in Scale Feet

People				Details - Food			
10312	Valdean		2.50	10701	Watermelon	Pkg (5)	1.25
10314	Arley		2.50	10702	Pumpkin	Pkg (5)	1.25
Details - Structures				10704	Gourd	Pkg (6)	1.50
10368	Brick Chimney w/ Smokejack		2.50	10713	Fruit Box		1.25
10476	Cone-top Smokejack, 19' High		2.50	Signs / Posters / Decals			
10780	Freight Door	Laser-Cut	3.50	10920	Color Poster Set, General Store I		2.45
10784	Skylight	Laser-Cut	3.50	10921	Color Billboard Set, General Store I		4.95
10806	Fire Hydrant	Pkg (3)	5.95	10922	Color Poster Set, General Store II		3.75
11000	Random Cedar Shingles	2 Sheets	4.00	10926	Color Poster Set, Business Variety I		2.45
11004	Octagonal Shingles	2 Sheets	4.00	10928	Color Poster Set, Business Variety II		2.45
11006	Diamond Shingles	2 Sheets	4.00	10930	Warning Signs		1.95
11008	Sawtooth Shingles	2 Sheets	4.00	10932	Color Poster Set, General Store III		2.45
11010	Three-Tab Shingles	2 Sheets	3.50	Freight Car Details			
11012	French Diamond Shingles	2 Sheets	3.50	12301	Westinghouse Air Brake Set		14.95
11014	Cedar Shake Shingles	2 Sheets	4.00	12302	Air Hoses (Flexible)	Pkg (4)	5.25
Tools				12600	Wood Deck, Atlas 52'-6" Gon		11.95
10610	Broadax	Pkg (2)	4.95	12608	Wood Deck, Weaver Flat #U25XX, Self Adh.		15.95
10645	Pickaroon	Pkg (2)	4.95	12611	Wood Deck, Weaver War Gon #U17XX		11.95
Details - Containers							
10612	Large Wooden Barrel		1.25				
10614	Small Barrel	Pkg (2)	2.00				
10741	Junk Box		1.50				
10742	Junk Drum		1.50				
10760	55-Gallon Drum		1.50				
10767	Large Crate	Laser-Cut	2.00				
10768	Medium Crate	Laser-Cut, Pkg (2)	2.00				
10769	Small Crate	Laser-Cut, Pkg (3)	2.00				

TT Scale

37103	Ballasted Deck Trestle, 50'	16' x 50'	16.95	37502	Single-Stall Switcher Shed	21' x 70'	39.95
37400	Flagstop Station	38' x 19'	24.95				
37435	Willet's Supply	45' x 24'	39.95	31010	Three-Tab Shingles	2 Sheets	3.50
37506	Loading Dock	16' x 78'	13.95	31012	French Diamond Shingles	2 Sheets	3.50
37106	Elliott & Sons Supply	40' x 60'	Soon		Shingles cover approximately 7 sq. in.		

All Scales

Details - Miscellaneous				Stumps			
91100	Scale Screen Wire	12 SQ IN	4.50	91106	Stump, Sapling (3/16" Top Dia.)	Pkg (18)	6.95
91101	Phos Bronze Scale Screen Wire	12 SQ IN	6.95	91111	Stump, Small (1/4" Top Dia.)	Pkg (12)	6.95
91105	Scale Rubber Hose	12 IN	1.50	91112	Stump, Medium (1/2" Top Dia.)	Pkg (9)	6.95
91110	0.0055" Magnet Wire	3 Feet	1.50	91113	Stump, Large (3/4" Top Dia.)	Pkg (6)	6.95
91250	Miniature Lamp	1.5 v	1.25				