



Kadee®

Quality Products Co.

Catalog

The Coupler People®



#148 Whisker® Coupler
Setting the standard in model
railroading coupling.

Kadee® Quality Products Co.
673 AVENUE C
WHITE CITY, OR 97503-1078
(541) 826-3883 FAX: (541) 826-4013
www.kadee.com mail@kadee.com



Patent number 5,662,229

MAGNE-MATIC®



1 Stopped over a Magnetic uncoupler, allowing slack to occur between the couplers. Knuckles have opened.



2 Withdraw slightly to disengage couplers. Magnetic force of the uncoupler draws couplers apart, uncoupling them.



3 Enter over uncoupler again, couplers are in delayed position allowing pushing of car(s) without causing re-coupling.



4 Withdraw, leaving uncoupled car(s) on desired track. Couplers automatically return to normal coupling position.

Notes:

INTRODUCTION AND TABLE OF CONTENTS

Here is the latest product catalog from Kadee® featuring HO_n3, HO, S, Sn3, O, On3, On30, *1 and G scale products offering you the finest line of scale components for model railroading. The needs of our customers encourage us to try harder to make new and better products. Many changes we make simply reflect these changing needs as well as taking advantage of new technology in precision machining and die casting. The one thing that never changes though is the Kadee® Product Guarantee.

KADEE® PRODUCT GUARANTEE

All Kadee® products are guaranteed to be free of defects in workmanship or materials for 1 Year. Product defects arising from improper usage, shipping by sources other than Kadee® or abuse will not be honored. Cosmetic or environmental defects will not be honored. All returns must be authorized prior to return. Returns are shipped at the full expense of the customer unless prior arrangements have been made. Return defective materials directly to us for replacement or repair. Be sure to package items carefully as we cannot replace parts damaged in transit, nor parts that are determined to be damaged due to misuse or abuse. Subject to change without notice.

KADEE® PRODUCT RETURN POLICY

Product returns must be authorized prior to return. Returns may be made only up to 30 days from date of invoice & will be subject to a 20% restocking fee. Returns must include a copy of the original invoice and reason for the return. Returns are shipped at the full expense of the customer unless prior arrangements have been made. We cannot accept the return of products purchased from sources other than Kadee® Quality Products. Returns with defects arising from improper usage or abuse will not be honored.

Most Kadee® products are available at your local hobby shop. Your hobby dealer is your best source of Kadee® products and can provide many suggestions to help you enjoy your hobby. If your dealer is unable to provide you with the products you need, you may place your order directly with us. Orders may be placed by Phone, Fax or Online. Some items may only be available factory direct.

RETAIL CUSTOMER ORDERING

A \$5.00 handling fee will apply to orders. Domestic surface shipped retail orders can be shipped USPS or UPS. All foreign orders will be shipped USPS. All retail customers are responsible for all insurance as needed. Shipping will be calculated by Kadee® at the time the order is received. Shipping charges will be calculated by: weight, size & manner of shipping & a \$5.00 Handling fee will apply to all orders. Orders may be paid for using VISA, MasterCard, Check, Cashiers Check or Money Order in US Dollars prior to sending the fulfilled order. A returned check fee of \$25 will be charged and accrued interest until paid in full. No C.O.D.'s. All customers are responsible for all taxes, duties, or customs fees.

We always welcome your questions or suggestions are always welcome at Kadee® for a reply to your questions e-mail us or mail us your question, please include a self-addressed, stamped #10 envelope. Be sure to mention the scale you are working in.

Orders are usually shipped the same day as received. All merchandise is subject to availability at the time the order is placed. All prices, Shipping & Handling charges are subject to change without prior notice. UPS Surcharges may apply.

We reserve the right to correct errors and to modify designs or discontinued products without notice or obligation.

Table of Contents

| | |
|--|------------------------|
| Coupler Primer..... | Reference - 2 |
| Kadee® Automatic Coupling & Uncoupling..... | Reference - 3 |
| NMRA Standards..... | Reference - 4 |
| HO_n3-Scale (1:87) | |
| Couplers & Accessories..... | HO _n 3 - 1 |
| Trucks & Wheelsets..... | HO _n 3 - 2 |
| HO-Scale (1:87) | |
| Couplers..... | HO - 1 thru HO - 9 |
| Bulk Pack Couplers..... | HO - 6 |
| Coupler Conversion Kits..... | HO - 9 |
| Test Kits..... | HO - 10 |
| Accessories..... | HO - 11 |
| Uncouplers..... | HO - 12 |
| Height Gauges & Spiker Parts..... | HO - 13 |
| Wheel Sets..... | HO - 14 |
| Trucks..... | HO - 15 thru 19 |
| Detail Parts..... | HO - 19 thru 21 |
| Log Cars & Accessories..... | HO - 22 |
| "RTR" Cars..... | HO - 23 thru 24 |
| S-Scale (1:64) | |
| Couplers & Accessories..... | S thru O - 1 & 2 |
| On3-Scale (1:48) | |
| Couplers & Accessories..... | S thru O - 1 & 2 |
| On30-Scale (1:48) | |
| Couplers & Accessories..... | S thru O - 2 |
| O-Scale (1:48) | |
| Couplers & Accessories..... | S thru O - 1 & 2 |
| #1-Scale (1:32) | |
| Couplers & Accessories..... | #1 & G - 1 thru 10 |
| G-Scale (1:22.5) | |
| Couplers & Accessories..... | #1 & G - 1 thru 10 |
| Multi-Scales | |
| Tools & Accessories..... | Multi - 1 & 2 |
| Decal Paper & Momentary Switches..... | Multi - 3 |
| Screws & Fasteners..... | Multi - 4 |
| General Info & Charts..... | Multi - 5-8 |
| Kadee® - RC System | |
| Components & Remote Couplers (#1 & G Scale)..... | Kadee® - RC - 1 thru 3 |
| Limited Warranty..... | Kadee® - RC - 4 |

COUPLER PRIMER

The Kadee® coupler primer will better acquaint you with the basics of the Magne-Matic® coupling and uncoupling system. Kadee® Quality Products Company is proud that its Magne-Matic® couplers are regarded as “the hobbies most respected couplers,” and in fact have become “The Standard by Choice” of model railroaders around the world. Also, we have included a list of terms and definitions used by Kadee® and much of the modeling world.

How We Arrived at Our Present Model Coupler

Model Railroading is a continually growing hobby beginning sometime in the early 1900's and has grown to the present day and it will continue into the distant future.

Manufactured models began as basic “toy like” models that could hardly be considered representative of the prototypes. Now days we have models that are so accurate that they are compared directly to the prototypes in almost every detail. Unfortunately, couplers did not advance at the same speed as the models and the industry suffered for a long time without a reliable functioning knuckle coupler. Modelers that have been in the hobby for a long time will remember the situation in the “old days” when, generally, couplers were not very reliable, realistic, or automatic.

When Kadee® Quality Products was formed it was with the idea of providing a reliable, realistic, automatic coupler and since 1942 Kadee® has remained a leader within the hobby.

Our earliest version of a knuckle coupler, the “K” series prototype was the first to combine a realistic looking coupler with a

feature where the coupler is never “locked” in a closed position. This allows the coupler to actually be “coupled” to at anytime and because of this feature the knuckle will flex while negotiating tight curves but still remain securely coupled. This was a major achievement, enthusiastically welcomed by the hobby.

Although a big stride forward, the “K” still required physical contact with a mechanical uncoupler. This was quite conventional for its day but not the most satisfactory arrangement. So after arriving at this acceptable “K” style coupler head with its realism and dependability, the next logical step was to eliminate the physical contact with mechanical uncoupling ramps.

This was achieved with the introduction of **Magne-Matic® Uncoupling** and was a major breakthrough utilizing magnetic force to actuate the coupler. The letter “M” was added to indicate a “K” style coupler operated magnetically and these became our “MK” series. Not long after this breakthrough, Kadee® developed **Delayed-Action Uncoupling**. Now it was possible to “spot” cars at most any location without having to actually uncouple them before pulling away. This, however, was not the end of the modelers coupler

problems. Now, even with a dependable functioning coupler, the modelers still faced the problems of properly mounting them on the many different types and makes of models, which sometimes required extensive modifications.

Kadee® realized that model manufacturers don't always agree on standards for coupler mounting. Because of this, we developed and now offer the largest variety of coupler box styles, “offset” couplers, and different shank lengths to help compensate for these coupler mounting variations. Since “all” of our couplers are actuated magnetically we no longer use the “MK” to designate them. We simply use a product number sign such as “5” coupler or #148 coupler, etc.

Kadee® Couplers have become the most respected couplers world wide due to constant research and development and a commitment to quality. We are always striving to improve the standards of the model railroading hobby.

What is Delayed Uncoupling

Delayed Magnetic Uncoupling® It is a unique way of keeping the couplers open and uncoupled while you push the cars to be dropped off (or spotted) at most any location. The Delayed Uncoupler is mounted just ahead of the leading turnout (switch) in any track serving a number of spurs and sidings. Couplers can be automatically set in the “**delayed position**” by first uncoupling (see illustrated uncoupling steps) then pulling forward to completely disengage couplers. The couplers are now in the delayed position, **offset** in opposing directions and will remain this way over the magnet. Now push back into the couplers and as long as there is “constant” pressure against the delayed couplers the cars now can be pushed or “**spotted**” to any location beyond the uncoupler without recoupling. Once at the desired location, simply pull away leaving the car/s at that location. The couplers will now snap back to center and are ready to be coupled again.

Kadee® Magne-Matic® Couplers are usually easy to install and can be adapted to almost any locomotive and rolling stock. Our couplers come with complete assembly instructions and, upon request, we provide special instructions and drawings for installations not covered in the couplers instructions, usually ones requiring some modifications.

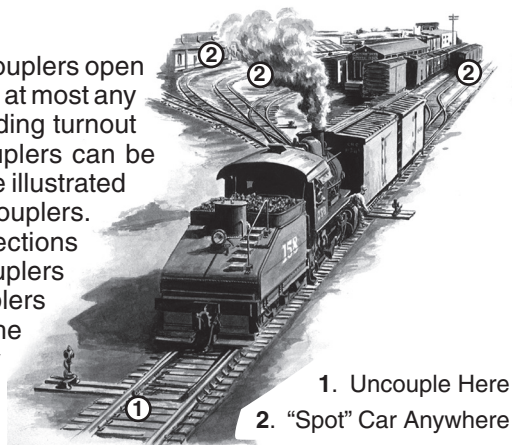

KADEE® AUTOMATIC COUPLING AND UNCOUPLING

KADEE® COUPLERS AND UNCOUPLERS

Kadee® Magne-Matic® Couplers with **Delayed-Action Uncoupling** offer freedom of operation and realistic prototype train movements, with a minimum of uncoupling devices. It is a complete “Hands Off System” and much more automatic than even those on full-size railroads. No actual hand contact occurs during uncoupling, thus assuring smooth, reliable performance. Our couplers can also be set in a “**delayed**” position that allows you to “**spot**” cars anywhere on the layout.

HOW KADEE® COUPLERS AND UNCOUPLERS WORK

The **Delayed-Action Couplers** are ready to couple at all times—just push two cars together and they automatically “couple up”. As two couplers are pushed together, the knuckles pivot aside to bypass each other, then are returned to the closed position by a coil spring, known as the knuckle spring.

Uncoupling with Kadee® Couplers is done over a magnetic “**uncoupler**” (uncoupling ramp). Uncoupling takes place when mated couplers are pushed to a stop over a magnetic uncoupler. Kadee® Couplers are equipped with a metal wire “**trip pin**” that curves down from the knuckle of the coupler head. The trip pins are slightly off center so when a pair of couplers are stopped over an uncoupler and slack occurs between the two couplers, the magnetic force of the uncoupler pulls the two trip pins in opposite directions out towards the rails thus opening and “uncoupling” the couplers. If you push or pull the cars away from the magnet, each coupler will automatically snap back to its centered position. (Knowing this, you realize that you “cannot recouple” over a magnetic uncoupler.) This operation is known as “**slack uncoupling**”, a very simple and reliable principle. Kadee® Couplers are designed so that it requires two conditions to be met for them to uncouple: **1.** Positioning the couplers over an uncoupler; and **2.** Slack being caused between the couplers. Therefore a train can be pulled over the uncoupler while keeping a steady tension and the cars will not accidentally uncouple.

In HO, to uncouple without Delayed-Action you must use our non-delayed “312 uncoupler mounted in correct position in your track. For HO Delayed-Action uncoupling, you must use one of our delayed uncouplers, “321 between the rails, “308 under the ties or “309 electric uncoupler.

MAGNE-MATIC®

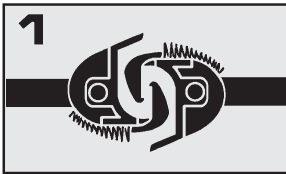

1
Stopped over a magnetic uncoupler, allowing slack to occur between the couplers. Knuckles have opened.

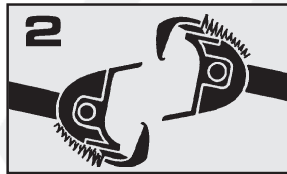

2
Withdraw slightly to disengage couplers. Magnetic force of the uncoupler draws couplers apart, uncoupling them.



3
Enter over uncoupler again, couplers are in delayed position allowing pushing of car(s) without causing recoupling.

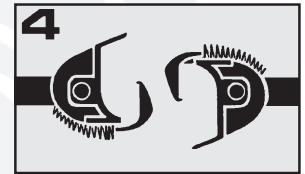

4
Withdraw, leaving uncoupled car(s) on desired track. Couplers automatically return to normal coupling position.

STANDARDS

The **National Model Railroad Association, Inc. (NMRA)**, is an organization formed in 1935 to bring order out of chaos caused by the lack of standardization in the fledgling hobby of model railroading. It is made up of hobbyists like yourself, who have set down the *standards* accepted and used by the majority in the hobby. **Official NMRA “Standards”**: Cover basic scale specifications and information on items which are critical to the functioning of model railroads and necessary to the interchange of equipment between layouts.

NMRA “Recommended Practices”: Cover items of preferred design that are slightly less critical than those in *standards*, but are desirable for improved performance and maximum interchange between components.

The *standards* set down by the **NMRA** help to standardize the industry, so to speak. They are the basics that most manufacturers try to follow when making model railroad equipment. This enables you to use equipment from different manufacturers and be assured that it will match up. We at **Kadee®** follow these **NMRA Standards and recommended practices** as closely as possible in all of our products. Our couplers are very close to prototype appearance, so they do require a different approach to adapting and mounting on your equipment. For this reason we included the illustrations for *standard* dimensions for HO_{n3}, HO, S, O, and On3 couplers. **It is very important that you mount the couplers (in all scales) at the proper height and exactly centered on your equipment.** If the manufacturer of a particular car or locomotive has followed the **NMRA** standards for height of the coupler pocket or draft gear box on their model, you should be able to adapt the **Kadee® Coupler** and Draft Gear to their equipment without difficulty. If they have not, you may have to do some custom work to adapt Kadee® Couplers.

NMRA STANDARDS

NMRA

If you are not already a member, there is much that you are missing, so we urge you to join. Write to NMRA, Inc., 4121 Cromwell Rd., Chattanooga, TN 37421, web site www.nmra.org, e-mail hg@hqnmra.org, phone (423) 892-2846, fax (423) 899-4869.

COUPLER CENTERLINE HEIGHTS

The N.M.R.A. Standard S-1 for coupler heights is measured from the top of the rail to the "center" of the couplers knuckle (coupler centerline). All Kadee® height gauges are designed to meet the N.M.R.A. S-1 standard which will ensure dependable and reliable performance. (N.M.R.A. S-1 page 52)

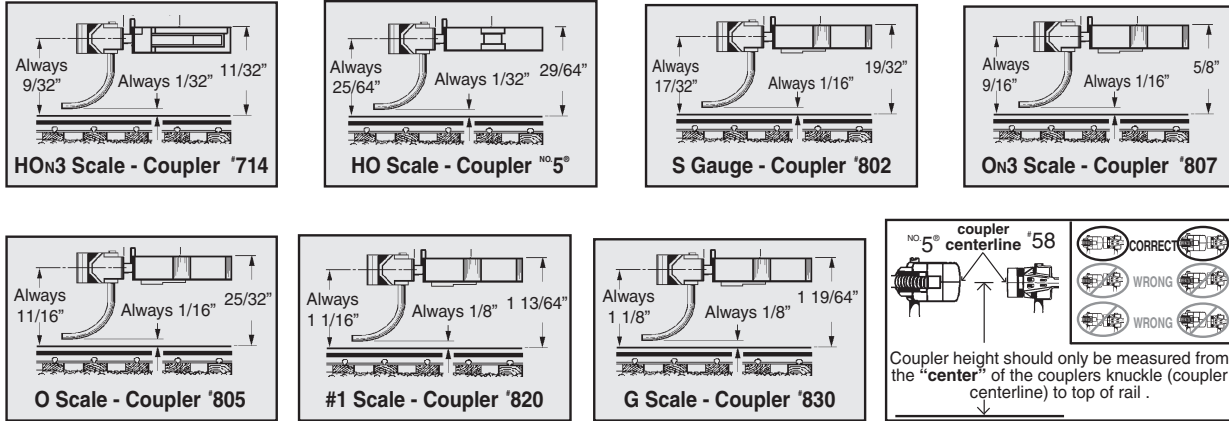

COUPLER HEIGHT & HEIGHT GAUGES

For the best and most reliable coupler performance the couplers need to be mounted at the "same height". To achieve the correct coupler height requires a coupler height gauge or couplers mounted correctly on a locomotive or rolling stock to be used as a gauge. Kadee® offers coupler height gauges for HO N3 (#704), HO (#205), S (#814), O N3 (#813), O (#812), #1 (#829), and "G" (#880) scale. The above chart indicates the correct coupler heights for each scale. Also note, that now in HO scale there are couplers made to actual "scale dimensions" (our #58, #78, and #2100) where the coupler head is about 20% smaller than the standard #5 type of coupler. You still can use a #205 HO height gauge with a standard coupler or a scale coupler because you are only measuring or looking at the "center" and not the top or bottom of the coupler regardless of the actual size of the coupler head.

TYPICAL PARTS OF KADEE® COUPLERS

The illustrations below will help easily identify the various coupler components. Regardless of scale, all couplers are essentially the same and operate in similar ways.

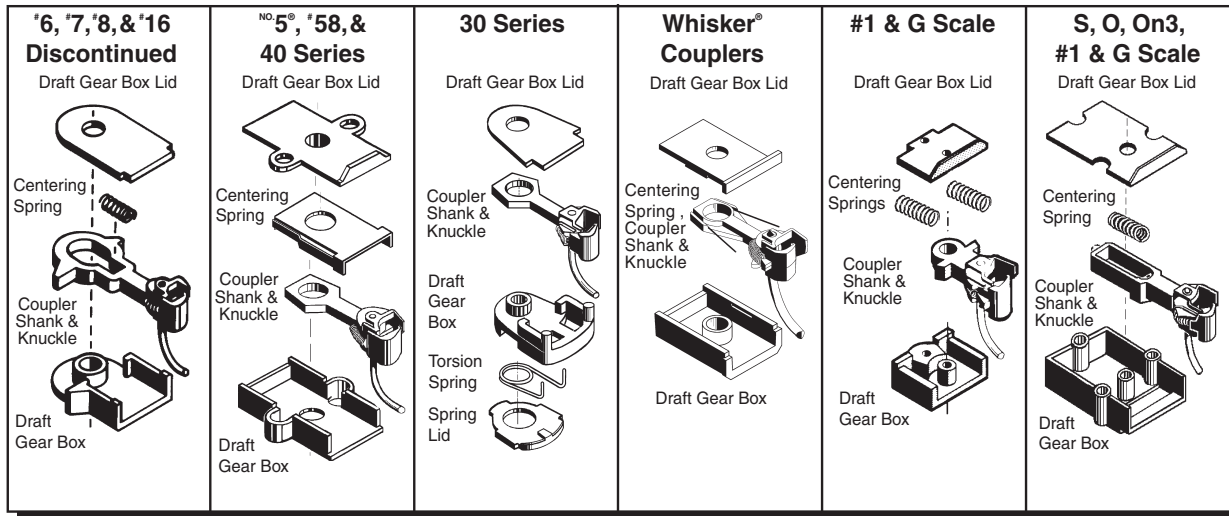

Important Kadee® Web Site Pages (www.kadee.com)

Catalog (updates) www.kadee.com/htmbord/catalog.htm
Handouts..... www.kadee.com/htmbord/handout.htm
Product Instructions www.kadee.com/htmbord/instruc.htm
Authorized Dealer Locator www.kadee.com/storelocator/
New Products www.kadee.com/htmbord/newprod.htm
Future Scheduled Freight Cars www.kadee.com/ca/preorder.htm

Coupler Conversion Info

HO Conversions www.kadee.com/conv/hocc.htm
Large-Scale Conversions www.kadee.com/conv/lssc.htm

Kadee® HO-Scale Standard & Whisker Coupler Chart



MAGNE-MATIC® COUPLERS
World's Best Magnetic Couplers!

Kadee® Manufactured
& Assembled in the
U.S.A.



Chart Key

SC = Short
Centerset Shank

SU = Short
Underset Shank

SO = Short
Overset Shank

MC = Medium
Centerset Shank

MU = Medium
Underset Shank

MO = Medium
Overset Shank

LC = Long
Centerset Shank

LU = Long
Underset Shank

LO = Long
Overset Shank

| | Plastic Standard Head with Metal Knuckles | Plastic Standard Head with Metal Knuckles | Metal Standard Head | Metal "Scale" Head | Metal Standard Head | Metal "Scale" Head | Metal "SF" Head | Metal "SE" Head | | | | |
|--|---|---|---|--------------------------|---------------------------|----------------------------------|---------------------------------|----------------------------------|---------------------------------|------------------------|---------------------------------|---------------------------------|
| | | | | | | | | | | | | |
| | Standard Couplers | Standard Couplers | Standard Couplers | Standard Couplers | Whisker® Couplers | Whisker® Couplers | Whisker® Couplers | Whisker® Couplers | | | | |
| | | | | | | | | | | | | |
| | Plastic Shank | Plastic Shank | Metal Shank | Metal Shank | Metal Shank | Metal Shank | Metal Shank | Metal Shank | | | | |
| | with 213 | with 233 | with 232 or 234 | with 9 | with 232 | with 451 | with 242 | with 115 | with 242 | with 178 | with 242 | with 242 |
| | | | | | | | | | | | | |
| | & 232 or 234 | | Gear Box | Gear Box | Gear Box | Extended Swing Gear Box | Snap Together Gear Box | Log Car Narrow Gear Box | Snap Together Gear Box | "Scale" Gear Box | Snap Together Gear Box | Snap Together Gear Box |
| | Gear Box Short Shank couplers get the 234 gear box option | Gear Box | Short Shank couplers get the 234 gear box option | | | | | | | | | |
| | KIT | KIT | KIT | KIT | KIT | KIT | KIT ASSY | KIT | KIT | KIT | KIT | KIT |

| | | | | | | | | | | | | | |
|------|----|----|-------|-------|-------|-------|-----|-------|-------|-------|-------|-------|-------|
| | 23 | 33 | ----- | ----- | ----- | ----- | 143 | ----- | ----- | 153 | ----- | ----- | ----- |
| "SC" | | | | | | | | | | | | | |
| | 24 | 34 | ----- | ----- | ----- | ----- | 144 | ----- | ----- | ----- | ----- | ----- | ----- |
| "SU" | | | | | | | | | | | | | |
| | 25 | 35 | ----- | ----- | ----- | ----- | 145 | ----- | ----- | ----- | ----- | ----- | ----- |
| "SO" | | | | | | | | | | | | | |
| | 28 | 38 | 5 | 9 | 58 | 451 | 148 | 3 | 115 | 158 | 178 | 118 | 119 |
| "MC" | | | | | | | | | | | | | |
| | 27 | 37 | ----- | ----- | ----- | ----- | 147 | ----- | ----- | ----- | ----- | ----- | ----- |
| "MU" | | | | | | | | | | | | | |
| | 22 | 32 | ----- | ----- | ----- | ----- | 142 | ----- | ----- | ----- | ----- | ----- | ----- |
| "MO" | | | | | | | | | | | | | |
| | 26 | 36 | ----- | ----- | ----- | ----- | 146 | ----- | ----- | 156 | ----- | ----- | ----- |
| "LC" | | | | | | | | | | | | | |
| | 21 | 31 | ----- | ----- | ----- | ----- | 141 | ----- | ----- | ----- | ----- | ----- | ----- |
| "LU" | | | | | | | | | | | | | |
| | 29 | 39 | ----- | ----- | ----- | ----- | 149 | ----- | ----- | ----- | ----- | ----- | ----- |
| "LO" | | | | | | | | | | | | | |

Patent numbers 5,662,229 & 5,785,192

Kadee® HO-Scale Couplers



Kadee® Manufactured
& Assembled in the
U.S.A.



MAGNE-MATIC® COUPLERS
World's Best Magnetic Couplers!

Standard Shank Couplers

Standard Head - Body Mount



2 pair of Couplers, #634 Centering Springs & Draft Gear Boxes *Note: The #148 coupler is the Whisker® Equivalent to the #5 coupler. See Offset Charts HO-1, HO-3, HO-4*

- #5^{no.5} Metal - Medium (9/32") Centerset Shank - #232 Gear Box
- #9 Metal - Medium (9/32") Centerset Shank - #9 Gear Box has a smaller center mounting hole in the gear box than the #232 Gear Box.

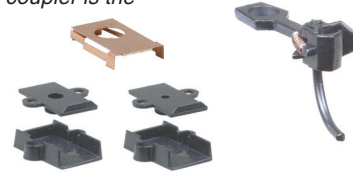

20-Series - Body or Talgo Mount



2 pair of Couplers, Offset Plastic Coupler Series with Metal Knuckles, with (#622) Coil Knuckle Spring, (#634) Bronze Centering Spring,

(#212) Talgo Truck Adapter, (#213) Gear Box & Sleeves, & Insulated (#232 or #234) Draft Gear Box.

Note: A 140-Series coupler mounted using the 213 or 232 gear box is equivalent mounting dimensions but stronger. See Offset Charts HO-1, HO-3, HO-4

- #21 Plastic - Long (25/64") Underset Shank - #213 & #232 Gear Box
- #22 Plastic - Medium (9/32") Overset Shank - #213 & #232 Gear Box
- #23 Plastic - Short (1/4") Centerset Shank - #213 & #234 Gear Box
- #24 Plastic - Short (1/4") Underset Shank - #213 & #234 Gear Box
- #25 Plastic - Short (1/4") Overset Shank - #213 & #234 Gear Box
- #26 Plastic - Long (25/64") Centerset Shank - #213 & #232 Gear Box
- #27 Plastic - Medium (9/32") Underset Shank - #213 & #232 Gear Box
- #28 Plastic - Medium (19/64") Centerset Shank - #213 & #232 Gear Box
- #29 Plastic - Long (25/64") Overset Shank - #213 & #232 Gear Box

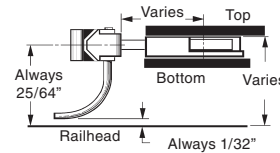
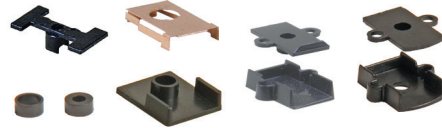

30-Series - Body Mount



2 pair of Couplers, Offset Plastic Coupler Series with Metal Knuckles, with (#622) Coil Knuckle Spring, (#621) Torsion Spring, & Insulated (#233) Draft Gear Box. *Note: A 140-Series coupler mounted with the #252 gear box is the 30-Series equivalent. mounting dimensions but stronger. See Offset Charts HO-1, HO-3, HO-4*

- #31 Plastic - Long (25/64") Underset Shank - #233 Gear Box
- #32 Plastic - Medium (9/32") Overset Shank - #233 Gear Box
- #33 Plastic - Short (1/4") Centerset Shank - #233 Gear Box
- #34 Plastic - Short (1/4") Underset Shank - #233 Gear Box
- #35 Plastic - Short (1/4") Overset Shank - #233 Gear Box
- #36 Plastic - Long (25/64") Centerset Shank - #233 Gear Box
- #37 Plastic - Medium (9/32") Underset Shank - #233 Gear Box
- #38 Plastic - Medium (19/64") Centerset Shank - #233 Gear Box
- #39 Plastic - Long (25/64") Overset Shank - #233 Gear Box

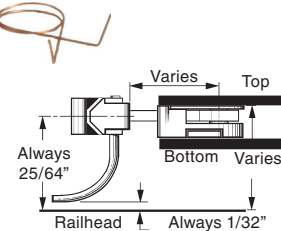

"Scale" Head - Body Mount



2 pair of "Scale" Head, Die Cast All Metal (9/32") Medium Centerset Standard Shank Coupler, with (#625) Coil Knuckle Spring, (#634) Bronze Centering Spring & Insulated (#232) Draft Gear Box. *Note: The #158 coupler is the Whisker® Equivalent to the #58 coupler. See Offset Charts HO-1, HO-3, HO-4*

- #58 Metal - Medium (19/64") Centerset Shank - #232 Gear Box



Kadee® HO-Scale Gear Box Mounting Dimensions



MAGNE-MATIC® COUPLERS
World's Best Magnetic Couplers!

Kadee® Manufactured
& Assembled in the
U.S.A.



Gear Box Mounting Dimensions

| Coupler in a #213 20-Series Gear Box mounted on Bottom | 30-Series Coupler or Whisker® Coupler in a #252 Gear Box mounted on the bottom | 30-Series Coupler or Whisker® Coupler in a #252 Gear Box mounted on the top | Coupler in a #232 Gear Box (™5" Type) or #242 Gear Box (Whisker® Type) |
|--|---|--|--|
| <p>21 141</p> | <p>31 141</p> | <p>30-Series Coupler or Whisker® Coupler in a #252 Gear Box mounted on the top</p> | <p>21 141</p> <p>Long Underset Shank</p> |
| <p>26 146 156</p> | <p>36 146 156</p> | <p>30-Series Coupler or Whisker® Coupler in a #252 Gear Box mounted on the top</p> | <p>26 146 156</p> <p>Long Centerset Shank</p> |
| <p>29 149</p> | <p>39 149</p> | <p>30-Series Coupler or Whisker® Coupler in a #252 Gear Box mounted on the top</p> | <p>29 149</p> <p>Long Overset Shank</p> |
| <p>27 147</p> | <p>37 147</p> | <p>30-Series Coupler or Whisker® Coupler in a #252 Gear Box mounted on the top</p> | <p>27 147</p> <p>Medium Underset Shank</p> |
| <p>No. 5®, 28, 58, 118, 119, 148, 158</p> | <p>38 118 119 148 158</p> | <p>30-Series Coupler or Whisker® Coupler in a #252 Gear Box mounted on the top</p> | <p>No. 5®, 28, 58, 118, 119, 148, 158</p> <p>Medium Centerset Shank</p> |
| <p>22 142</p> | <p>32 142</p> | <p>30-Series Coupler or Whisker® Coupler in a #252 Gear Box mounted on the top</p> | <p>22 142</p> <p>Medium Overset Shank</p> |
| <p>24 144</p> | <p>34 144</p> | <p>30-Series Coupler or Whisker® Coupler in a #252 Gear Box mounted on the top</p> | <p>24 144</p> <p>Short Underset Shank</p> |
| <p>23 143 153</p> | <p>33 143 153</p> | <p>30-Series Coupler or Whisker® Coupler in a #252 Gear Box mounted on the top</p> | <p>23 143 153</p> <p>Short Centerset Shank</p> |
| <p>25 145</p> | <p>35 145</p> | <p>30-Series Coupler or Whisker® Coupler in a #252 Gear Box mounted on the top</p> | <p>25 145</p> <p>Short Overset Shank</p> |

Patent numbers 5,662,229 & 5,785,192

Kadee® HO-Scale Offset Couplers Chart



Kadee® Manufactured
& Assembled in the
U.S.A.



MAGNE-MATIC® COUPLERS
World's Best Magnetic Couplers!

| | | | |
|--|--|--|------------------------------------|
| 21, 31, 141* | | "LU" Long Underset Shank Raises knuckle height about .050" | Long Center Set Shank |
| 26, 36, 146*, 156* | | "LC" Long Center Set Shank Knuckle is centered | |
| 29, 39, 149* | | "LO" Long Overset Shank Lowers knuckle height about .050" | |
| 27, 37, 147* | | "MU" Medium Underset Shank Raises knuckle height about .050" | Medium Center Set Shank |
| No.5®, 9, 28, 38, 58, 118*, 119*, 148*, 158* | | "MC" Medium Center Set Shank Knuckle is centered | |
| 22, 32, 142* | | "MO" Medium Overset Shank Lowers knuckle height about .050" | |
| 24, 34, 144* | | "SU" Short Underset Shank Raises knuckle height about .050" | Short Center Set Shank |
| 23, 33, 143*, 153* | | "SC" Short Center Set Shank Knuckle is centered | |
| 25, 35, 145* | | "SO" Short Overset Shank Lowers knuckle height about .050" | |

This Chart Represents Kadee® Coupler Shank Variations.

* Denotes couplers with the Whisker® Shank all other couplers use the Standard Shank. All couplers listed will function in each others draft gear boxes with exception of the 30-Series #233 gear box will not work with Whisker® Couplers. The #252 gear box is the Whisker® Coupler 30-Series equivalent gear box.

No.5®, 9, 58, & all Whisker® Couplers are all metal.
20 & 30 Series Couplers have plastic insulated shanks and metal knuckles.

© 2016 Kadee Quality Products Co.

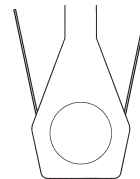

* Whisker® Shank

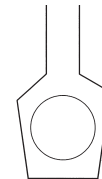

Standard Shank

Patent numbers 5,662,229

The Standard Shank design found on the #5, 9, 58, 20-Series, & 30-Series Couplers allows the couplers to be easily interchanged with #213, 232 (medium & long), 233, 234 (short), & 242 draft gear boxes as well as "molded on" coupler pockets.

The Whisker® Shank design found on the new #3, 115, 118, 119, 141, 142, 143, 144, 145, 146, 147, 148, 153, 156, 158, 178, & 451 couplers allows the couplers to be easily interchanged with #213, 232, 234, 242, 252, & 262 draft gear boxes as well as "molded on" coupler pockets.

#58 Coupler
+
12.3 LBS
+
#58 Coupler



Performance You Can Count On!

Compatible with all HO Scale Kadee® couplers.

Kadee® Couplers Out Pull & Perform All "Third World Knock Offs (CLONES)" Hands Down. No "CLONE" can even start to measure up to Kadee's® Quality, Trouble Free Performance, Durability and Reputation.

The Original and Still the Best!

Find the latest HO-Scale coupler conversions on our web site.

Conversion List

www.kadee.com/conv/holist.pdf

Conversion Drawings

www.kadee.com/conv/ho.htm

Patent numbers 5,662,229 & 5,785,192

Kadee® HO-Scale Whisker® Couplers



MAGNE-MATIC® COUPLERS
World's Best Magnetic Couplers!

Kadee® Manufactured
& Assembled in the
U.S.A.



Whisker® Shank Magne-Matic® Couplers

Standard Head Whisker® Couplers

2 pair of Couplers except as noted, Offset Die Cast All Metal Whisker® Coupler Series, with #622 Coil Knuckle Spring, & Insulated Draft Gear Box. Note: #148 Coupler has the same mounting dimensions, quality & dependability as the #5®.
See Offset Charts HO-1, HO-3, HO-4

with #115 Log Car Gear Box - for use on Kadee® logging cars.

#115 Metal - #148 Medium (9/32") Centerset Shank



#115

with #242 Snap Together Gear Box See Offset Chart

#3 Metal - Assembled #148 Coupler & #242 Gear Box

#141 Metal - Long (25/64") Underset Shank

#142 Metal - Medium (9/32") Overset Shank

#143 Metal - Short (1/4") Centerset Shank

#144 Metal - Short (1/4") Underset Shank

#145 Metal - Short (1/4") Overset Shank

#146 Metal - Long (25/64") Centerset Shank

#147 Metal - Medium (9/32") Underset Shank

#148 Metal - Medium (9/32") Centerset Shank

#149 Metal - Long (25/64") Overset Shank

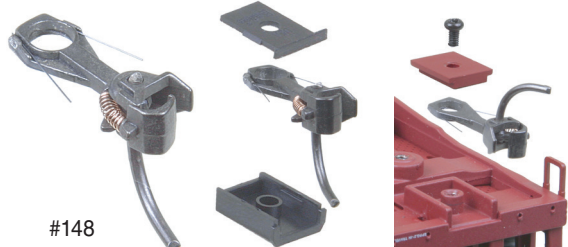

#148

with #451 Extended Swing Gear Box - for passenger or long freight cars. Perfect for negotiating tighter radius curves.

#451 Metal - #148 Medium (9/32") Centerset Shank (1 pair)



#451

Shelf Head Whisker® Couplers

2 pair of Couplers, Die Cast All Metal Fully Functioning Shelf Whisker® Coupler Series, with #622 or #625 Coil Knuckle Spring, & Insulated #242 Draft Gear Box.

See Offset Charts HO-1, HO-3, HO-4

#118 Metal - Type "SF" Shelf - Medium (9/32") Centerset Shank, #622 Coil Knuckle Spring

#119 Metal - Type "SE" Shelf - Medium (9/32") Centerset Shank, #625 Coil Knuckle Spring



#118



#119

"Scale" Head Whisker® Couplers

2 pair of Couplers, Offset Die Cast All Metal "Scale" Whisker® Coupler Series, with (#625) Coil Knuckle Spring, & Insulated #242 Draft Gear Box. Note: #158 Coupler has the same mounting dimensions, quality & dependability as the #58.

See Offset Charts HO-1, HO-3, HO-4

with #242 Snap Together Gear Box See Offset Chart

#153 Metal - Short (1/4") Centerset Shank

#156 Metal - Long (25/64") Centerset Shank

#158 Metal - Medium (9/32") Centerset Shank

with #178 "Scale" Snap-together Gear Box

#178 Metal - #158 Medium (9/32") Centerset Shank



#153

#156

#158

#178

Patent numbers 5,662,229 & 5,785,192

Kadee® HO-Scale Bulk Pack Couplers



Kadee® Manufactured
& Assembled in the
U.S.A.



MAGNE-MATIC® COUPLERS
World's Best Magnetic Couplers!

Bulk Pack Couplers

| | #5 Couplers without Gearboxes | #58 "Scale" Couplers without Gearboxes | #148 Whisker® Couplers without Gearboxes | #158 "Scale" Whisker® Couplers without Gearboxes |
|-------------------|--|---|---|---|
| | | | | |
| 10 Pair Bulk Pack | 10 | ----- | ----- | ----- |
| 20 Pair Bulk Pack | 11 | 12 | ----- | ----- |
| 25 Pair Bulk Pack | ----- | ----- | 14 | 150 |
| 50 Pair Bulk Pack | ----- | ----- | 140 | 151 |

Bulk Packs Standard & Whisker® Couplers

Kadee® Metal Knuckle & Centering Springs Won't Take a Set.



Standard Shank Bulk Pack Couplers

Standard Shank, Die Cast All Metal Couplers, with Coil Knuckle Springs, & (#634) Bronze Centering Springs, without draft gear boxes.



- #10 Metal - #5 Couplers (10 Pair)
- #11 Metal - #5 Couplers (20 Pair)
- #12 Metal - #58 "Scale" Couplers (20 Pair)



Whisker® Shank Bulk Pack Couplers

Whisker® Shank, Die Cast All Metal Couplers, with Coil Knuckle Springs, without draft gear boxes.



- #14 Metal - #148 Couplers (25 Pair)
- #118-25 Metal - #118 "SF" Couplers (25 Pair)
- #119-25 Metal - #119 "SE Scale" Couplers (25 Pair)
- #140 Metal - #148 Couplers (50 Pair)
- #150 Metal - #158 "Scale" Couplers (25 Pair)
- #151 Metal - #158 "Scale" Couplers (50 Pair)
- #153-25 Metal - #153 "Scale" Couplers (25 Pair)
- #156-25 Metal - #156 "Scale" Couplers (25 Pair)



Patent numbers 5,662,229 & 5,785,192

Kadee® HO-Scale Specialty Shank Couplers











MAGNE-MATIC® COUPLERS
World's Best Magnetic Couplers!

Kadee® Manufactured
& Assembled in the
U.S.A.

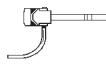

Specialty Shank Couplers

| | Metal Standard Head  Couplers  Metal Shank Designed For Locomotive Pilots | Metal "Scale" Head  Tear Drop Couplers  Metal Shank | Plastic 3/4 Size Old Time Head  Couplers  Metal Shank | |
|---|--|---|---|-------|
| | with 8 Gearboxes | with PS-1 Boxcar 2100 "Scale" Gearboxes | Black | Rust |
| | KIT | ASSEMBLED | KIT | KIT |
| Medium Shank  | 8 | ----- | ----- | ----- |
| Medium Centerset Shank  | ----- | 2100 | 711 | 712 |

3/4 Size Old Time Coupler - Body Mount

2 pair of 3/4 Size Old Time Head, Plastic Coupler, with (#636) Coil Centering Spring, & Draft Gear Box.
Same as the #714 except with longer Trip Pin. *(The #702 Coupler Assembly Fixture can be used to ease assembly)*

- #711 Plastic - Black
- #712 Plastic - "Rust" Color

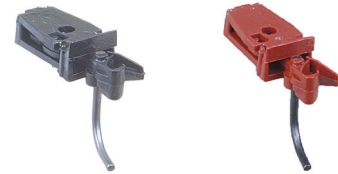

"Scale" Head & Gear Box PS-1 Replacement

1 pair "Scale" Head, Die Cast All Metal Medium Centerset Shank Coupler, with (#625) Coil Knuckle Spring, & "Scale" Insulated Draft Gear Box. **FACTORY ASSEMBLED**

- #2100 Metal - Medium Centerset Shank & Scale PS-1 Gear box

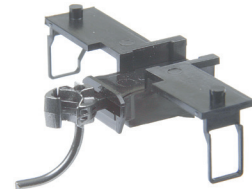

Kadee® HO-Scale NEM-362 Couplers



Kadee® Manufactured
& Assembled in the
U.S.A.



MAGNE-MATIC® COUPLERS
World's Best Magnetic Couplers!

NEM 362 Couplers





Plastic Standard Head

Swallow-Tail Shank



without Gear boxes

ASSEMBLED

| | |
|---|----|
| Short Shank NEM 362 Coupler  7.11mm (9/32") | 17 |
| Medium Shank NEM 362 Coupler  8.63mm (11/32") | 18 |
| Long Shank NEM 362 Coupler  10.61mm (27/64") | 19 |
| Extra Long Shank NEM 362 Coupler  11.68mm (29/64") | 20 |

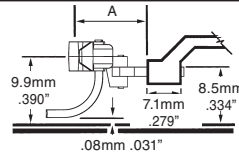

A
SHORT 7.11mm (9/32")
MEDIUM 8.63mm (11/32")
LONG 10.61mm (27/64")
EXTRA LONG 11.68mm (29/64")

Standard Head - NEM-362

2 pair Snap-In Couplers for European Equipment, with (#622) Coil Knuckle Spring, & (#620) Centering Spring.
For use with HO-scale NEM-362 draft gear pocket not included.

- #17 Plastic - Short - 7.11mm (9/32")
- #18 Plastic - Medium - 8.63mm (11/32")
- #19 Plastic - Long - 10.61mm (27/64")
- #20 Plastic - Extra Long - 11.68mm (29/64")

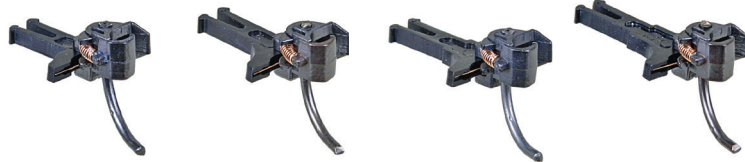

Securing Truck Springs With Glue

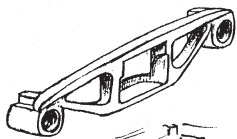

501 side frame
note "nubs"

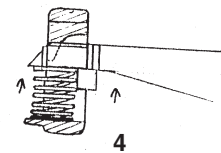
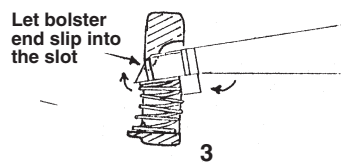
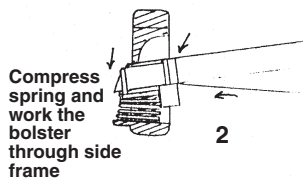
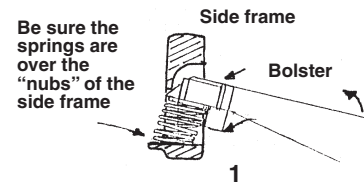
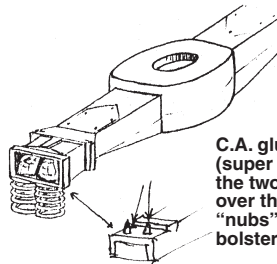

Kadee® HO-Scale Conversion Kits



MAGNE-MATIC® COUPLERS
World's Best Magnetic Couplers!

Kadee® Manufactured
& Assembled in the
U.S.A.



Conversion Kits

Coupler Conversion Kits

Each kit includes Replacement bracket, Couplers & Gear Boxes.

- #450 For Stewart F-3 "A" & "B" & F-7 "A" & "B" Locomotives (Not For EMD FT "A" & "B" Locomotives)
- #452 For Bachmann Plus F-7 "A" & "B" Locomotives
- #455 For LIFE-LIKE® PROTO 2000™ "E-7" "A" & "B" & PA/PB Locomotives

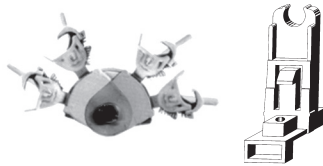

Extended Swing Gear Box Kits

- #451 1 pair of #148 Medium (9/32") Centerset Shank Whisker® Couplers, with #622 Coil Knuckle Spring, & #451 Insulated Extended Swing Gear Box. for passenger or long freight cars for negotiating tighter radius curves.



#451

- #454 Swing Bracket Adaptor Kit, Designed to provide a wide swinging coupler mounting bracket for locomotives and cars (60' and over) using modified 30-Series Gear Box included. The bracket allows negotiation of 18" radius "S" curves, switch ladders and crossovers. (Couplers Not Included)



Passenger Cars Conversion Bolsters

1 pair of passenger car conversion bolsters with Metal Medium Centerset Couplers. Each kit includes Standard Head, Die Cast All ^{NO 5} Metal Medium Centerset Standard Shank Couples, with (#622) Coil Knuckle Spring, (#634) Bronze Centering Spring, Conversion Bolster & Draft Gear Box.

- #505 For AHM, IHC, Con-Cor & Rivarossi 6-Wheel
- #508 For AHM, IHC, Con-Cor & Rivarossi 4-Wheel

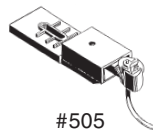

#505

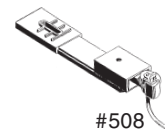

#508

Lube or Cement Applicators

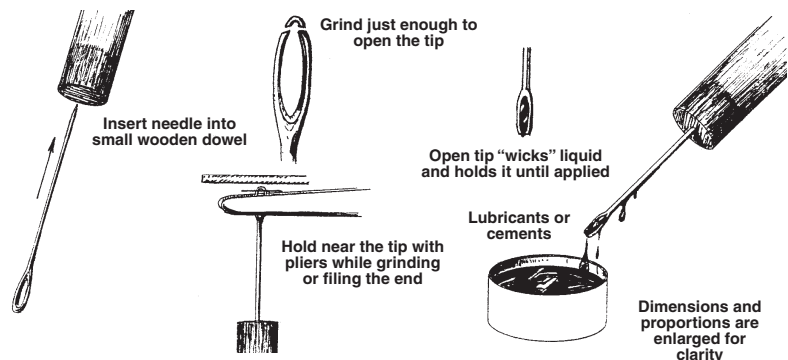

Patent numbers 5,662,229

Kadee® HO-Scale Coupler Kits



Kadee® Manufactured
& Assembled in the
U.S.A.



MAGNE-MATIC® COUPLERS
World's Best Magnetic Couplers!

Coupler Kits

Coupler Sample Test Kit

#13

Couplers One Pair of Each

^{no}5° Medium Centerset - Metal, #21/31 Long Underset - Plastic, #22/32 Medium Overset - Plastic, #23/33 Short Centerset - Plastic, #24/34 Short Underset - Plastic, #25/35 Short Overset - Plastic, #26/36 Long Centerset - Plastic, #27/37 Medium Underset - Plastic, #28/38 Medium Centerset - Plastic, #29/39 Long Overset - Plastic, #141 Long Underset - Metal, #142 Medium Overset - Metal, #143 Short Centerset - Metal, #144 Short Underset - Metal, #145 Short Overset - Metal, #146 Long Centerset - Metal, #147 Medium Underset - Metal, #148 Medium Centerset - Metal, #149 Long Overset - Metal, #158 "Scale" Medium Centerset

Gear Boxes, Adaptors One Sprue of Each

#212 Talgo Truck Adaptors
#213 20-Series with Sleeves
#232 ^{no}5° Type
#233 30-Series
#234 Short ^{no}5° Type
#242 Whisker® Snap-Together
#252 Small Whisker® Snap-Together

Screws, Springs, Washers, & Shims

#208 .015" Red Fiber Washer
#209 .010" Gray Fiber Washer
#211 .010" & .015" Shims
#256 Plastic 2-56 x 1/2" Screws
#621 30-Series Torsion Spring
#622 Knuckle Springs
#634 ^{no}5° Type Centering Spring

Uncouplers One Each

#321 Code 100 Between-The-Rails
#322 Code 83 Between-The-Rails

Tools One Each

#231 Greas-em
#206 Coupler Height Gauge
#241 Dual Tool



HO-Scale Starter Kit

This package of Kadee® products is designed to assist the beginning model railroader in learning the basic modeling skills of proper coupler mounting and use of the Magne-Matic® coupler system. The following items are a basic selection of assorted couplers and related products that should be enough for the beginner to acquire the knowledge needed for proper coupler selection and mounting. **Includes Two Pair of Couplers**

#1030

^{no}5° 2 Pair of Couplers, All Metal Medium Centerset
#142 Whisker Coupler, 2 Pair, All Metal Medium Overset
#143 Whisker Coupler, 2 Pair, All Metal Short Centerset
#146 Whisker Coupler, 2 Pair, All Metal Long Centerset
#147 Whisker Coupler, 2 Pair, All Metal Medium Underset
#148 Whisker Coupler, 2 Pair, All Metal Medium Centerset
#158 Whisker Coupler, "Scale Head" All Metal Medium Centerset
#206 HO Coupler Height Gauge, Multi Purpose
#208 .010" Thick Fiber Washer Shims, Red
#209 .015" Thick Fiber Washer Shims, Gray
#211 Plastic Shims .010" and .015" Thick, for draft gear boxes
#231 Greas-em Dry Graphite Lubricant
#237 Trip Pin Pliers (For adjusting coupler trip pins, HO_{n3} to O Scale)
#241 "Dual" Tool (Manual Uncoupling and Spring Pick Combination)
#256 Plastic 2-56 x 1/2" Screws
#321 Permanent Code 100 Between the Rails Magnetic Uncoupler
#322 Permanent Code 83 Between the Rails Magnetic Uncoupler
#334 Uncoupler Gluing Jig



Patent numbers 5,662,229 & 5,785,192

Kadee® HO-Scale Coupler Accessories



MAGNE-MATIC® COUPLERS
World's Best Magnetic Couplers!

Kadee® Manufactured
& Assembled in the
U.S.A.



Accessories

Talgo Adaptors

- #211 Gear Box Shims .010" & .015" thick For all HO-Scale Gear Boxes.
- #212 Talgo Truck Adaptors (use the #230 insertion pic to install)



#211



#212

Centering Springs

- #620 For NEM Couplers #17, #18, #19, #20
- #621 For 30-Series Couplers
- #634 For ^{no}5°, #9, 20-Series, 40-Series, #58, #505, #506, #507, #508 & old style #3, #118 Couplers
- #635 For #7 & #8 Couplers
- #636 For #711, #712, #714, & #715 Couplers



#620



#621



#634



#635



#636

Knuckle Springs

- #622 For use with all "Standard" Head HO-Scale Couplers
- #625 For use with all "Scale" Head Couplers #58, #78, #119, 150-Series & #2100 Couplers



Gear Boxes With Lids

All Gear Boxes are Insulated Plastic.

- #213 Included in 20-Series Couplers - with .055" & .100" sleeves - Works with ^{no}5°, #58, 20-Series, 40-Series & all Whisker® Couplers
- #232 For ^{no}5°, #21, #22, #26, #27, #28, #29, #58 & all Whisker® Couplers
- #233 For 30-Series Couplers
- #234 For #23, #24, #25, #45 Couplers also works with all Whisker® Couplers
- #242 Snap-together Gear Box For all Whisker® Couplers, ^{no}5°, #58, #118, #119, 20-Series, 40-Series, 140-Series & 150-Series
- #252 Small Snap-together Gear Box for all Whisker® Couplers. Whisker® Coupler equivalent to 30-Series Gear Box
- #262 Low Profile & Narrow Snap-together Gear Box For all Whisker® Couplers

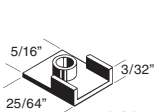

#213

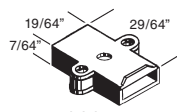

#232

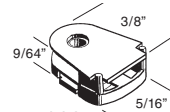

#233

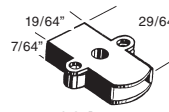

#234

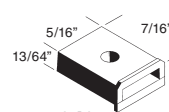

#242

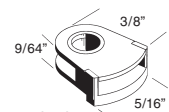

#252

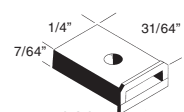

#262

Freight Car Storage Boxes

Keep your freight cars clean and safe when they are not in use. Clear plastic storage boxes and lids. Lid securely snaps to box for added protection. (One Each)

- #3000 Plastic Box Only
- #3010 Plastic Box & 40' Boxcar Nest
- #3011 Plastic Box & 50' Boxcar Nest
- #3012 Plastic Box & Hopper Nest
- #3013 Plastic Box & Open Hopper Nest
- #3014 Plastic Box & Tank Car Nest

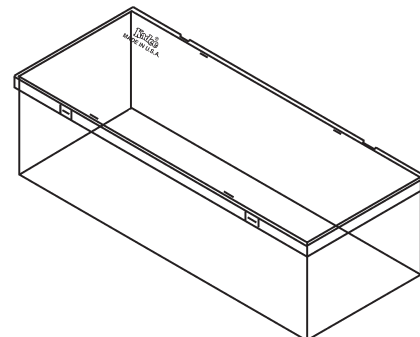

Kadee® HO-Scale Uncouplers



Kadee® Manufactured
& Assembled in the
U.S.A.



MAGNE-MATIC® COUPLERS
World's Best Magnetic Couplers!

Uncouplers

Electric Delayed Uncoupler (Track Not Included)

#309 "Under-the-Track" - Fits any HO Code track. Operates: 16 volt DC.
We recommend a 16 volt DC power source (at least 3 Amps) or
18 volt AC power source (at least 3 Amps) converted to DC with bridge rectifier.

Use (normally open) Momentary Switches with Electric Uncouplers.
Like #165 Momentary Quickie Switches
The #166 Transformer meets AC power source voltage requirements.

WARNING: Do not use the uncoupler continually. **DO NOT activate the uncoupler for longer than 2 MINUTES at one time.** This will avoid possible overheating which will damage the uncoupler.

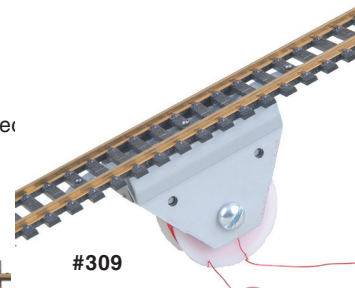
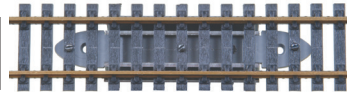

Delayed Uncouplers

#308 HO thru O-Scale - "Under-the-Track"
Permanent Delayed Magnet (Track Not Included)

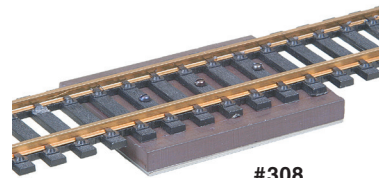

Use the #334 Uncoupler Gluing Jig to aid in precision installation "Between-The-Rails" Uncouplers.

#321 "Between-the-Rails" - Code 100 Delayed Magnet (Track Not Included)
#322 "Between-the-Rails" - Code 83 Delayed Magnet, Also fits Code 70 to 55
with track modification (Track Not Included)

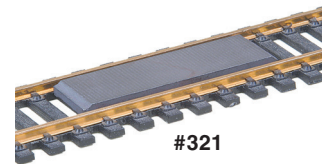

Non-Delayed Uncouplers

Uncouplers Only. Does not open knuckle enough for Delayed Position.

Use the #334 Uncoupler Gluing Jig to aid in precision installation "Between-The-Rails" Uncouplers.

#312 "Between-the-Rails" - Permanent Non-Delayed Magnet (Track Not Included)

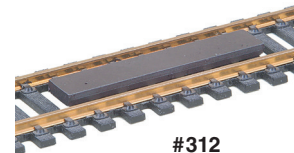

Uncoupler Gluing Jig

#334 Uncoupler Gluing Jig - Aid in precision installation of "Between-the-Rails" Uncouplers in track.



For Installing Kadee®
#312, #321 & #322
Permanent
Magnet Uncouplers

Uncoupling magnet

Magnet embedded in glue

Kadee® Jig

Ties

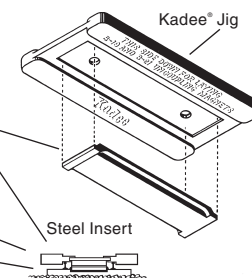

Kadee® HO-Scale Height Gauges & Spikes



MAGNE-MATIC® COUPLERS
World's Best Magnetic Couplers!

Kadee® Manufactured
& Assembled in the
U.S.A.



Coupler Height Gauges

Coupler Height Gauges

- 1) Provides instant visual reference of proper coupler height, standard and "scale" size couplers included
- 2) Accurately measures proper trip pin height above the rail
- 3) Built-in track gauge (N.M.R.A. Standard)
- 4) Moveable dowel tests Kadee® Magne-Matic® Uncoupler height and registers the needed adjustments
- 5) (#206 only) Provides instant visual reference of proper body mounting height.

- #205 All Metal Coupler Height Gauge
- #206 Insulated Coupler Height Gauge

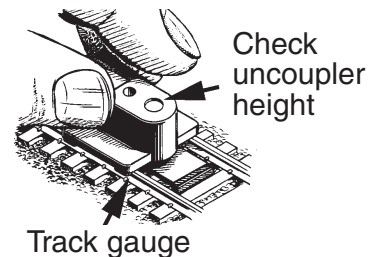
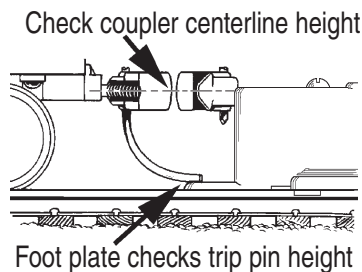
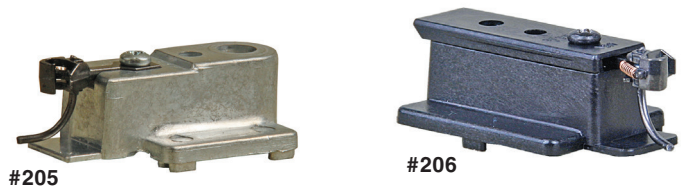

Twin "Rail Spiker"

Spikes

Only for use with the Kadee® Twin "Rail Spiker".
Approximately 4000 per box

- #700-31 For Code 70 & Code 83
- #700-32 For Code 100



Twin "Rail Spiker" Parts

Only for use with the Kadee® Twin "Rail Spiker".
Subject to stock on hand only

Common Replacement Parts

- 700-14 Hammer Spring
- 700-19 Cutter Blade code 70
- 700-20 Cutter Blade code 100
- 700-21 Cutter Head code 70
- 700-22 Cutter Head code 83 & 100
- 700-25 Cutter Blade code 83

Spiker Conversion Kits

- 700-70A Spiker Conversion Kit converts code 100 to code 70
- 700-83B Spiker Conversion Kit converts code 70 to code 83
- 700-100A Spiker Conversion Kit converts code 70 to code 100

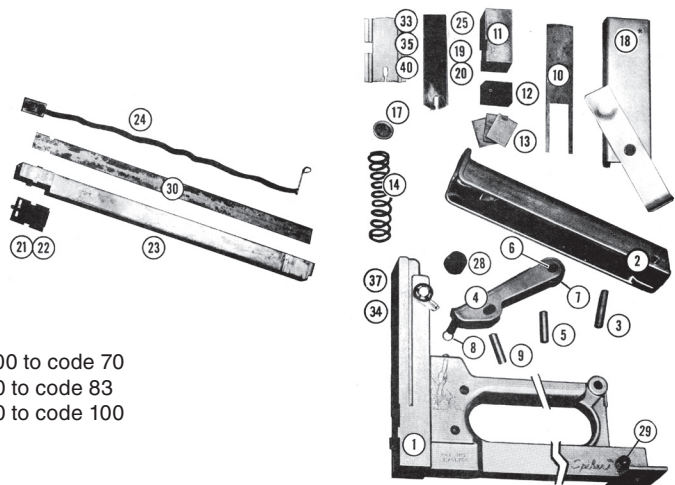

Patent numbers 5,662,229 & 5,785,192

Kadee® HO-Scale Wheelsets



Kadee® Manufactured
& Assembled in the
U.S.A.



MAGNE-MATIC® COUPLERS
World's Best Magnetic Couplers!

Wheelsets

Freight & Passenger Code 110 "Standard" Wheels

Non Magnetic Free Rolling Contoured Axles with RP-25 Contour Wheels.
Twelve Sets

- #520 Wheel Set - 33" Smooth Back
- #521 Wheel Set - 36" Ribbed Back
- #522 Wheel Set - 36" Smooth Back
- #523 Wheel Set - 33" Ribbed Back
- #524 Wheel Set - 28" Smooth Back



Code 110
"Standard"
Wheels

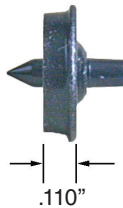

Freight & Passenger Code 88 "Semi-Scale" Wheels

Non Magnetic Free Rolling Contoured Axles with RP-25 Contour Wheels.
Twelve Sets

- #530 Wheel Set - 33" Smooth Back
- #531 Wheel Set - 36" Ribbed Back
- #532 Wheel Set - 36" Smooth Back
- #533 Wheel Set - 33" Ribbed Back



Code 88
"Semi-Scale"
Wheels

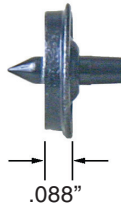

The term Code 110 and Code 88 relates to the width of the wheels and has no relationship to track code. Code 110 wheels are .110" wide and Code 88 are .088" wide. Code 110 wheels are the common (or standard) width wheels and Code 88 are what is called "semi scale" and are used when the modeler wants a more prototypical looking wheel width. Actual HO-Scale prototypical wheel width would be around .067" wide and although they will run OK on the average track they will not go through common turnouts and crossings. Code 88 (.088") is just about the minimum width of wheel that will run on most standard or common track if gauged correctly. It really is a matter of appearances because there's very little operational differences between running Code 110 or Code 88 wheels. Code 88 wheels look really good and are most noticeable on open frame cars like hoppers and tank cars. However, they also look great on box cars, gondolas, and reefers but not quite as noticeable. As mentioned above track code and wheel code have no relationship meaning Code 110 and Code 88 will run on most any code of track. Track code is simply the measured height of the rail, code 100 is .100" tall, code 83 is .083" tall, code 70 is .070" tall, and so on.

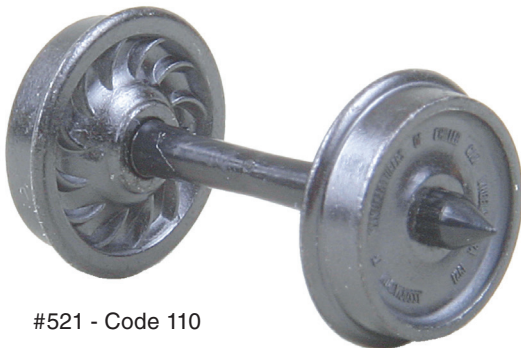

#521 - Code 110

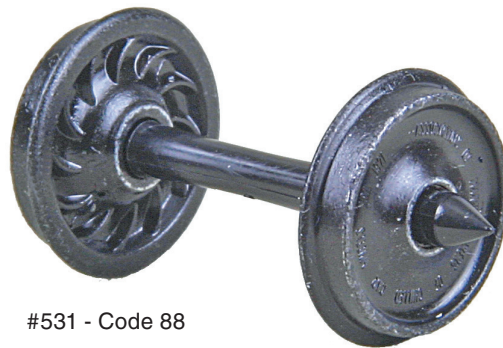

#531 - Code 88

Kadee® HO-Scale Freight Trucks



MAGNE-MATIC® COUPLERS
World's Best Magnetic Couplers!

Kadee® Manufactured
& Assembled in the
U.S.A.



Kadee® offers 4 variations of our HO-Scale Trucks.

Metal Fully Sprung, Equalized Trucks: All metal trucks with functioning spring design for truck equalization. Metal RP-25 wheels with insulated plastic axles, & scale clip on brake pads & brake rigging or cast on brake rigging*.
#500*, 501*, 504, 509*, 511*, 513, 515*, 517*, 518

Metal Fully Sprung, Equalized Trucks with Couplers: All metal trucks with functioning spring design for truck equalization. Metal RP-25 wheels with insulated plastic axles, scale clip on brake pads & brake rigging cast on brake rigging*, now with truck mount Whisker® Couplers. #502*, 503*, 510, 512*, 516*

Metal Fully Sprung, Equalized Trucks with Self-Centering: All metal trucks with functioning spring design for truck equalization. Metal RP-25 wheels with insulated plastic axles, scale clip on brake pads & brake rigging or cast on brake rigging*, & Self-Centering Action. The Self-Centering Action trucks self align themselves parallel with the car for easier placement on track.
#550*, 551*, 552, 553*, 554*, 555, 556*, 557*, 558

"HGC" Two Piece, Equalized Trucks with Self-Centering: "HGC" High Gravity Compound weighs nearly the same as Metal Trucks but with more detail & a 2 piece split bolster design for more efficient truck equalization, reduced axle friction for greater rolling performance. Metal RP-25 Code 110 or Code 88* wheels with insulated plastic axles, scale clip on brake pads & brake rigging, & Self-Centering Action. The Self-Centering Action trucks self align themselves parallel with the car for easier placement on track. Patent number 7,434,518 B2
#560, 561, 562, 563, 564, 565, 566, 567, 568, 569, 570, 571, 572, 573, 580, 581, 582, 583, 1560*, 1561*, 1562*, 1563*, 1564*, 1565*, 1566*, 1567*, 1568*, 1569*, 1570*, 15671*, 1572*, 1573*, 1580*, 1581*, 1582*, 1583*

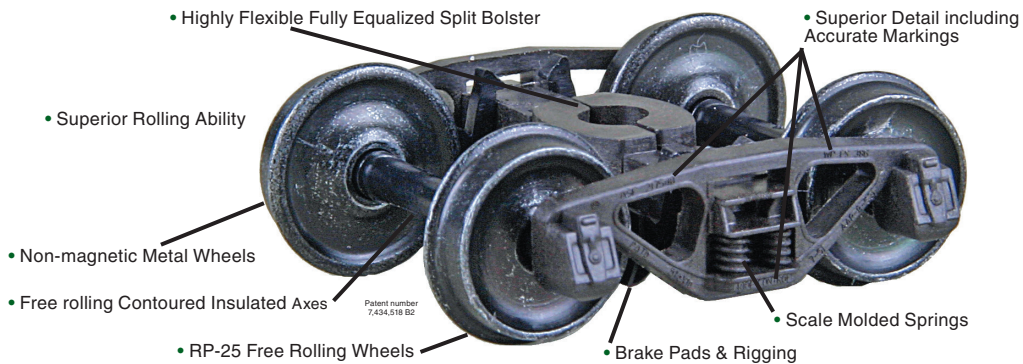

A.S.F.® A-3 Ride-Control® #562 "HGC" - Self Centering

Metal Fully Sprung Freight Trucks

Andrews (1898) Freight Truck

Metal Fully Sprung Freight Trucks (One Pair)

- #509 33" ribbed back code 110 "standard" wheels
- #553 Self Centering, 33" ribbed back code 110 "standard" wheels

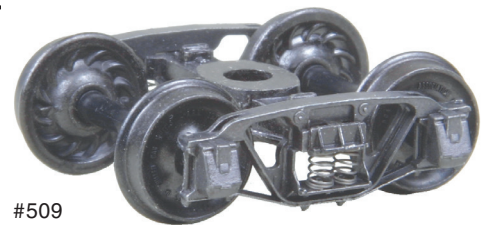

#509

Arch Bar Freight Truck

Metal Fully Sprung Freight Trucks (One Pair)

- #501 33" ribbed back code 110 "standard" wheels
- #551 Self Centering, 33" ribbed back code 110 "standard" wheels

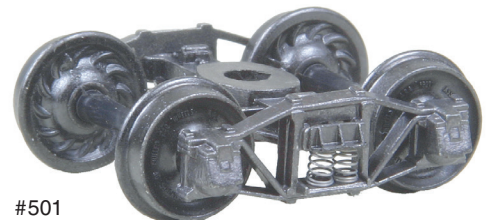

#501

Kadee® HO-Scale Freight Trucks



Kadee® Manufactured
& Assembled in the
U.S.A.



MAGNE-MATIC® COUPLERS
World's Best Magnetic Couplers!

A.S.F® A-3 Ride-Control® 50-Ton Freight Truck

Metal Fully Sprung Freight Trucks (One Pair)

- #504 33" smooth back code 110 "standard" wheels
- #552 Self Centering, 33" smooth back code 110 "standard" wheels

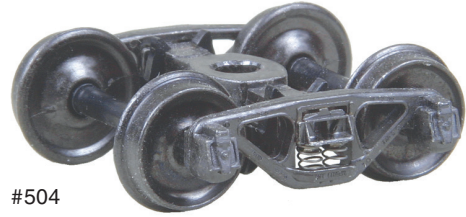

#504

Barber® S-2, S-2-B, & S-2 (ACL) 70-Ton Freight Truck

Metal Fully Sprung Freight Trucks (One Pair)

- #518 33" smooth back code 110 "standard" wheels
- #558 Self Centering, 33" smooth back code 110 "standard" wheels

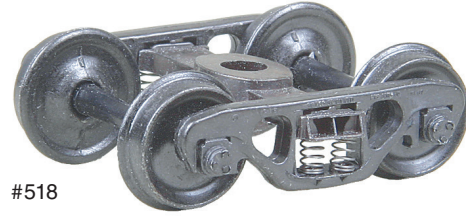

#518

Bettendorf 50-Ton Freight Truck

Metal Fully Sprung Freight Trucks (One Pair)

- #500 33" smooth back code 110 "standard" wheels
- #550 Self Centering, 33" smooth back code 110 "standard" wheels

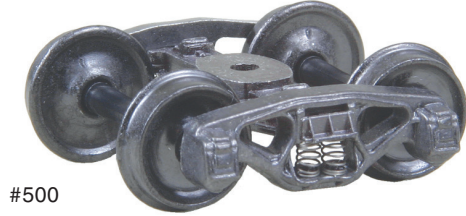

#500

Bettendorf T-Section Freight Truck

Metal Fully Sprung Freight Trucks (One Pair)

- #511 33" ribbed back code 110 "standard" wheels
- #554 Self Centering, 33" ribbed back code 110 "standard" wheels

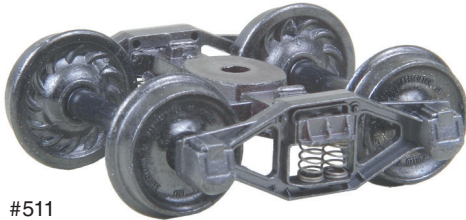

#511

Pennsylvania 2D-F8 50-Ton Freight Truck

Metal Fully Sprung Freight Trucks (One Pair)

- #517 33" ribbed back code 110 "standard" wheels
- #557 Self Centering, 33" ribbed back code 110 "standard" wheels



#517

Roller Bearing 100-Ton Freight Truck

Metal Fully Sprung Freight Trucks (One Pair)

- #513 36" smooth back code 110 "standard" wheels
- #555 Self Centering, 36" smooth back code 110 "standard" wheels

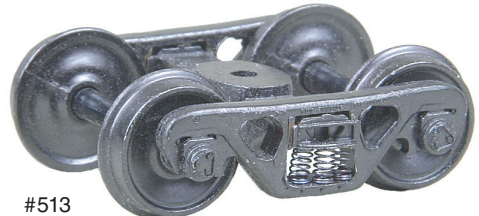

#513

Vulcan Double Truss Freight Truck

Metal Fully Sprung Freight Trucks (One Pair)

- #515 33" ribbed back code 110 "standard" wheels
- #556 Self Centering, 33" ribbed back code 110 "standard" wheels

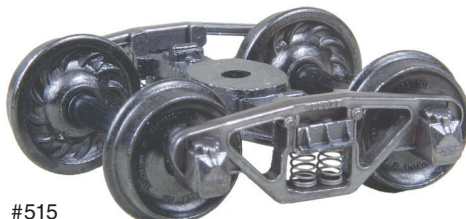

#515

Patent numbers 5,768,999, 5,832,837

Kadee® HO-Scale Freight Trucks with Couplers



MAGNE-MATIC® COUPLERS
World's Best Magnetic Couplers!

Kadee® Manufactured
& Assembled in the
U.S.A.



Metal Fully Sprung Freight Trucks with Couplers

Andrews (1898) Freight Truck

Metal Fully Sprung Freight Trucks (One Pair)

#510 Ready-to-Mount Whisker® Couplers, 33" ribbed back code 110 "standard" wheels

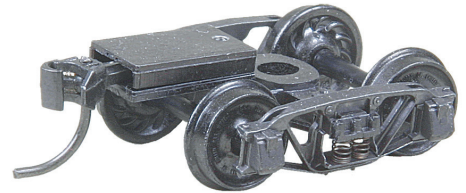

#510

Arch Bar Freight Truck

Metal Fully Sprung Freight Trucks (One Pair)

#503 Ready-to-Mount Whisker® Couplers, 33" ribbed back code 110 "standard" wheels

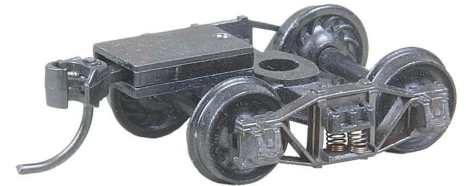

#503

Bettendorf 50-Ton Freight Truck

Metal Fully Sprung Freight Trucks (One Pair)

#502 Ready-to-Mount Whisker® Couplers, 33" smooth back code 110 "standard" wheels

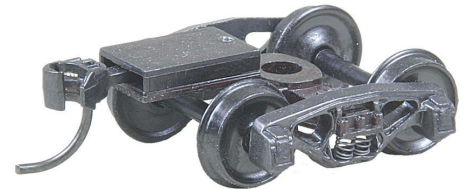

#502

Bettendorf T-Section Freight Truck

Metal Fully Sprung Freight Trucks (One Pair)

#512 Ready-to-Mount Whisker® Couplers, 33" ribbed back code 110 "standard" wheels

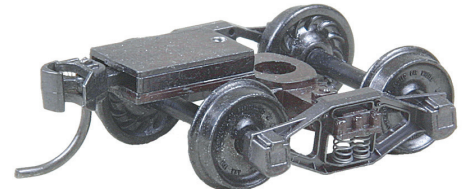

#512

Vulcan Double Truss Freight Truck

Metal Fully Sprung Freight Trucks (One Pair)

#516 Ready-to-Mount Whisker® Couplers, 33" ribbed back code 110 "standard" wheels

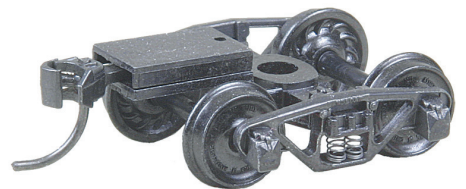

#516

Truck Springs

Truck Springs

#637 - Truck Springs - For all except #513, #555 & "HGC" Two Piece Freight Trucks

#638 - Truck Springs - For #513 & #555 Freight Trucks



Brake Pads

Brake Pads

4 Ready to use

#441 For use on all Kadee® Trucks; Except for 70 Ton, 100 Ton & Electrical Pickup Trucks.
(Except #513, #518, #555, #558, #560, #566, #569, #570, #590, #593, #1560, #1566, #1569 & #1570)

#442 For use on Kadee® 70 & 100 Ton Trucks.
(Use on #513, #518, #555, #558, #560, #566, #569, #570, #1560, #1566, #1569 & #1570)



Patent numbers 5,662,229

Kadee® HO-Scale “HGC” Freight Trucks



Kadee® Manufactured
& Assembled in the
U.S.A.



MAGNE-MATIC® COUPLERS
World's Best Magnetic Couplers!

“HGC” Two Piece Freight Trucks

Arch Bar Freight Truck

“HGC” Two Piece Self Centering Freight Trucks (One Pair)

- #561 33” ribbed back code 110 “standard” wheels
- #1561 33” ribbed back code 88 “semi-scale” wheels

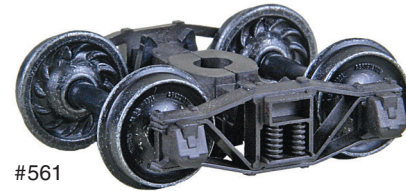

#561

A.S.F® A-3 Ride-Control® 50-Ton Freight Truck

“HGC” Two Piece Self Centering Freight Trucks (One Pair)

- #562 33” smooth back code 110 “standard” wheels
- #563 33” ribbed back code 110 “standard” wheels
- #1562 33” smooth back code 88 “semi-scale” wheels
- #1563 33” ribbed back code 88 “semi-scale” wheels

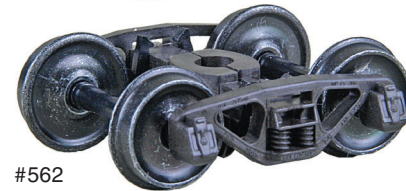

#562

Barber® S-2, S-2-B, & S-2 (ACL) 70-Ton Freight Truck

“HGC” Two Piece Self Centering Freight Trucks (One Pair)

- #560 S-2 (ACL) Truck, 33” smooth back code 110 “standard” wheels
- #566 S-2-B Truck, 33” smooth back code 110 “standard” wheels
- #570 S-2 Truck, 33” smooth back code 110 “standard” wheels
- #1560 S-2 (ACL) Truck, 33” smooth back code 88 “semi-scale” wheels
- #1566 S-2-B Truck, 33” smooth back code 88 “semi-scale” wheels
- #1570 S-2 Truck, 33” smooth back code 88 “semi-scale” wheels

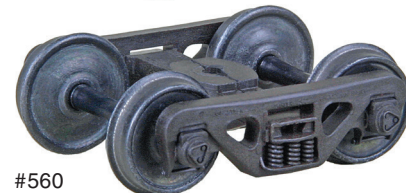

#560

Bettendorf 50-Ton Freight Truck

“HGC” Two Piece Self Centering Freight Trucks (One Pair)

- #564 33” smooth back code 110 “standard” wheels
- #565 33” ribbed back code 110 “standard” wheels
- #1564 33” smooth back code 88 “semi-scale” wheels
- #1565 33” ribbed back code 88 “semi-scale” wheels

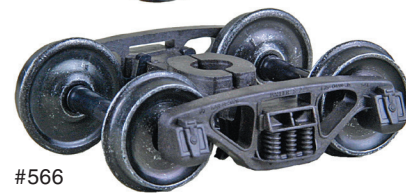

#566

National type B-1 50-Ton Freight Truck

“HGC” Two Piece Self Centering Freight Trucks (One Pair)

- #567 33” ribbed back code 110 “standard” wheels
- #568 33” smooth back code 110 “standard” wheels
- #1567 33” ribbed back code 88 “semi-scale” wheels
- #1568 33” smooth back code 88 “semi-scale” wheels

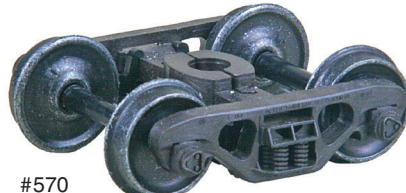

#570

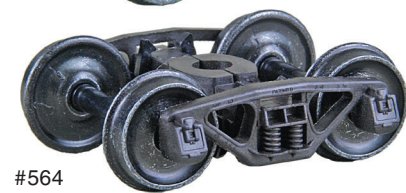

#564

Roller Bearing 100-Ton Freight Truck

“HGC” Two Piece Self Centering Freight Trucks (One Pair)

- #569 36” smooth back code 110 “standard” wheels
- #1569 36” smooth back code 88 “semi-scale” wheels

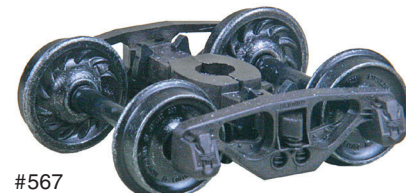

#567

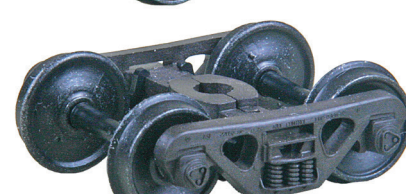

#569



.110”
Code 110
“Standard”
Wheels

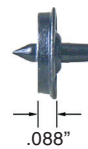

.088”
Code 88
“Semi-Scale”
Wheels

“HGC” = “High Gravity Compound”

Patent numbers 7,434,518 B1

Kadee® HO-Scale “HGC” Freight & Caboose Trucks



MAGNE-MATIC® COUPLERS
World's Best Magnetic Couplers!

Kadee® Manufactured
& Assembled in the
U.S.A.



“HGC” Two Piece Freight Trucks

Andrews (1898) Freight Truck

“HGC” Two Piece Self Centering Freight Trucks (One Pair)

- #571 33” ribbed back code 110 “standard” wheels
- #1571 33” ribbed back code 88 “semi-scale” wheels

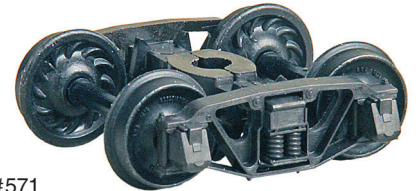

#571

Bettendorf T-Section Freight Truck

“HGC” Two Piece Self Centering Freight Trucks (One Pair)

- #572 33” ribbed back code 110 “standard” wheels
- #1572 33” ribbed back code 88 “semi-scale” wheels

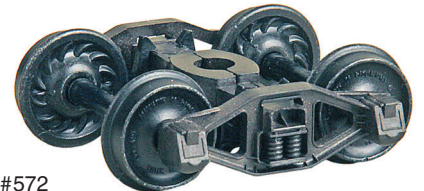

#572

Vulcan Double Truss Freight Truck

“HGC” Two Piece Self Centering Freight Trucks (One Pair)

- #573 33” ribbed back code 110 “standard” wheels
- #1573 33” ribbed back code 88 “semi-scale” wheels

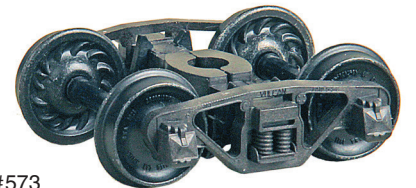

#573

“HGC” Two Piece Caboose Trucks

Bettendorf - AAR

“HGC” Two Piece Self Centering Caboose Trucks (One Pair)

- #580 33” smooth back code 110 “standard” wheels
- #1580 33” smooth back code 88 “semi-scale” wheels

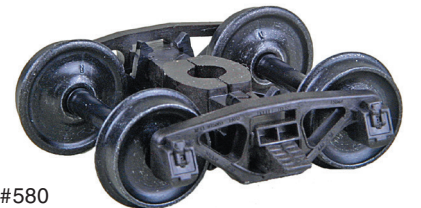

#580

Bettendorf T-Section

“HGC” Two Piece Self Centering Caboose Trucks (One Pair)

- #581 33” ribbed back code 110 “standard” wheels
- #1581 33” ribbed back code 88 “semi-scale” wheels

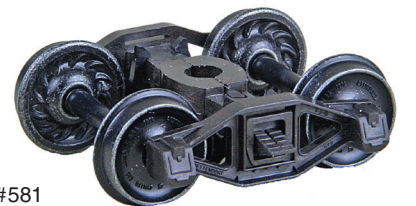

#581

Barber - Bettendorf Roller Bearing

“HGC” Two Piece Self Centering Caboose Trucks (One Pair)

- #582 33” smooth back code 110 “standard” wheels
- #1582 33” smooth back code 88 “semi-scale” wheels

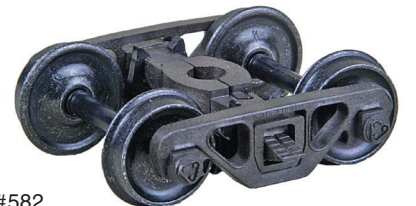

#582

Arch Bar

“HGC” Two Piece Self Centering Caboose Trucks (One Pair)

- #583 33” ribbed back code 110 “standard” wheels
- #1583 33” ribbed back code 88 “semi-scale” wheels

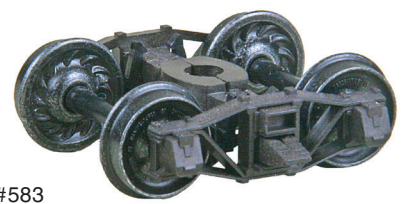

#583

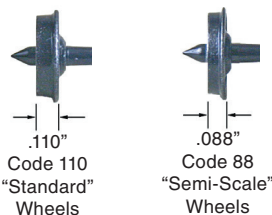

“HGC” = “High Gravity Compound”

Patent numbers 7,434,518 B1

Kadee® HO-Scale Electrical Pickup Caboose Trucks



Kadee® Manufactured
& Assembled in the
U.S.A.



MAGNE-MATIC® COUPLERS
World's Best Magnetic Couplers!

“HGC” Two Piece Electrical Pickup Caboose Trucks

Bettendorf - AAR

“HGC” Two Piece Self Centering
Electrical Pickup Caboose Trucks (One Pair)
#590 33” smooth back code 110 wheels

Arch Bar

“HGC” Two Piece Self Centering
Electrical Pickup Caboose Trucks (One Pair)
#593 33” smooth back code 110 wheels

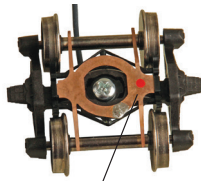
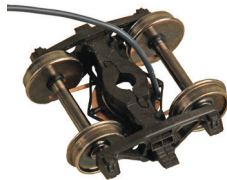

The red dot indicates the hot side or the side that picks up the current.

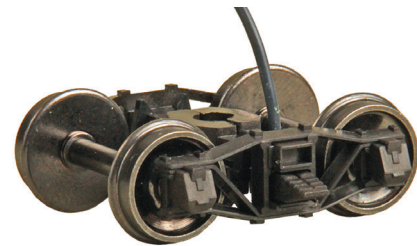
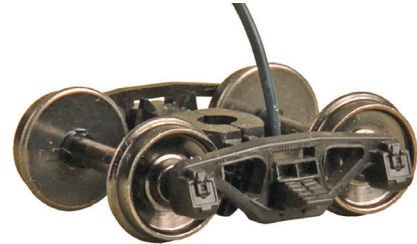

Optional: Use the #169 Rectifier Kit to Convert AC or DC track current to polarized DC current suitable for LED lighting and other electronic devices that require DC current.

“HGC” = “High Gravity Compound”

WARNING: If the trucks are not orientated correctly it will cause an electrical short.

Rectifier Kit

Rectifier Kit

Converts AC or DC track current to polarized DC current suitable for LED lighting and other electronic devices that require DC current.

#169 Rectifier Kit

Optional: For Kadee® #590 & #593 Electrical Pickup Trucks.

See kadee website for wiring diagram.

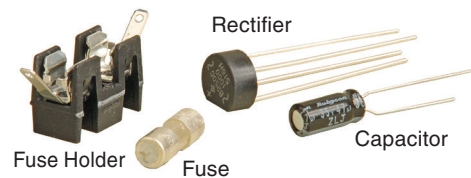

Kadee® HO-Scale Detail Parts



MAGNE-MATIC® COUPLERS
World's Best Magnetic Couplers!

Kadee® Manufactured
& Assembled in the
U.S.A.



Detail Parts

Whistle Post & Yard Limit Marker

#426 Whistle Post & Yard Limit Marker with optional stick on labels. 6 ea.

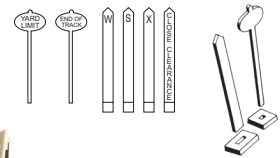

Cattle Guards

#437 Cattle Guards. 3 ea.

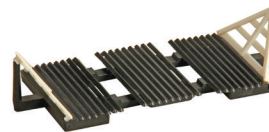

Air Hose Angle Cock

#438 Add that final touch of scale realism to your locomotives and rolling stock. The delicate scale appearance of these air hose assemblies will amaze you. They'll enhance the finest models built. Get a supply and complete the detailing of equipment that requires this appealing feature. *TWENTY PER PACKAGE*



Nut-Bolt-Washer

#439 Cast in metal, the nut is slightly less than .030" square, the washer is .053" in diameter. The shank press fits into a 1/32" hole Useful in any scale. *THREE DOZEN*



Apex Running Boards

40 Foot 1 pr
#2000 Red Oxide
#2001 Boxcar Red
#2002 Black
#2003 Galvanized

50 Foot 1 pr
#2010 Red Oxide
#2011 Boxcar Red
#2012 Black
#2013 Galvanized

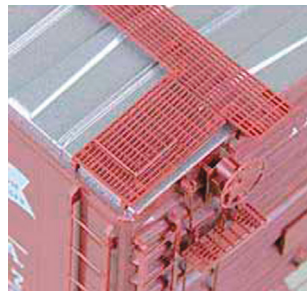

End & Side Ladders

#2101 Red Oxide 1 set
#2102 Boxcar Red 1 set
#2103 Black 1 set

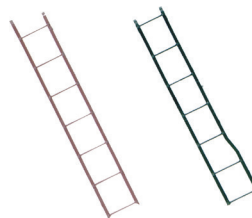

Grab Irons

Side Grab Irons 16 ea
#2250 Red Oxide
#2251 Boxcar Red

End Grab Irons 4 pr
#2252 Red Oxide
#2253 Boxcar Red
#2254 Black

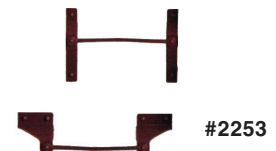

Hopper Coal Loads

#171 Lump/Egg (small) 6 ea
#172 Large Lump (medium) 6 ea
#173 Mine Run (large) 6 ea
#174 Coal Load Weights 3 ea



Kadee® HO-Scale Detail Parts



Kadee® Manufactured
& Assembled in the
U.S.A.



MAGNE-MATIC® COUPLERS
World's Best Magnetic Couplers!

Brake Wheels

#440 Metal Die Cast Brake Wheels, 6 Per Package



Plastic Brake Wheels, 8 Per Package

Ajax

- #2020 Boxcar Red
- #2030 Red Oxide
- #2040 Black



Equipco

- #2021 Boxcar Red
- #2031 Red Oxide
- #2041 Black



Miner

- #2022 Boxcar Red
- #2032 Red Oxide
- #2042 Black



Universal

- #2023 Boxcar Red
- #2033 Red Oxide
- #2043 Black



Champion

- #2024 Boxcar Red
- #2034 Red Oxide
- #2044 Black



Modern

- #2025 Boxcar Red
- #2035 Red Oxide
- #2045 Black



Doors

Youngstown Doors 2 Pair

Low Tack

- #2202 6' Red Oxide
- #2203 6' Boxcar Red
- #2236 7' Red Oxide
- #2237 7' Boxcar Red
- #2220 8' Red Oxide
- #2221 8' Boxcar Red
- #2245 9' Narrow, Boxcar Red
- #2246 9' Wide, Boxcar Red
- #2260 10' Narrow, Boxcar Red
- #2261 10' Wide, Boxcar Red

High Tack

- #2200 6' Red Oxide
- #2201 6' Boxcar Red
- #2234 7' Red Oxide
- #2235 7' Boxcar Red
- #2215 8' Red Oxide
- #2216 8' Boxcar Red



#2201



#2203



#2245



#2246

Superior Doors 2 Pair

Low Tack

- #2207 6' 5 Panel, Red Oxide
- #2208 6' 5 Panel, Boxcar Red
- #2240 7' 5 Panel, Red Oxide
- #2241 7' 5 Panel, Boxcar Red
- #2230 8' 6 Panel, Red Oxide
- #2231 8' 6 Panel, Boxcar Red
- #2248 9' 6 Panel, Boxcar Red
- #2263 10' 6 Panel, Boxcar Red
- #2264 10' Superior 150, Gray

High Tack

- #2205 6' 5 Panel, Red Oxide
- #2206 6' 5 Panel, Boxcar Red
- #2210 6' 7 Panel, Red Oxide
- #2211 6' 7 Panel, Boxcar Red
- #2238 7' 5 Panel, Red Oxide
- #2239 7' 5 Panel, Boxcar Red



#2206



#2208



#2211



#2248



#2264

PS Doors 2 Pair

Low Tack

- #2225 8' PS, Red Oxide
- #2226 8' PS, Boxcar Red
- #2247 9' PS, Boxcar Red
- #2262 10' PS, Boxcar Red



#2247

Kadee® HO-Scale Log Car Kits

Kadee®

MAGNE-MATIC® COUPLERS

World's Best Magnetic Couplers!

Kadee® Manufactured
& Assembled in the
U.S.A.



Kadee Cars LOGGING

DELAYED
MAGNETIC
UNCOUPLING®

ALL KADEE® LOG CARS ARE STANDARD EQUIPPED WITH:

- Craftsman Quality detailing engineered throughout the plastic & die-cast metal components.
- Kadee® Magne-Matic® Metal Couplers with delayed centering action for accurate, reliable coupling that lasts & lasts.
- Kadee® smooth rolling non magnetic metal RP-25 wheels & fully sprung metal trucks.
- Precision balanced for optimum performance.
- Made in the U.S.A.

LOG CAR KITS

Disconnect

- #101 - Disconnect Log Car Kit
- #101bab - Disconnect Bunk Only
- #107 - Disconnect Log Car without Logs Kit



#101- Disconnect Log Car

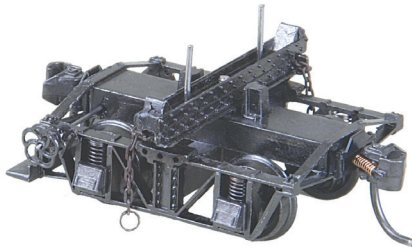

#107- Disconnect Log Car without Logs

Skeleton

- #102 - Skeleton Log Car Kit
- #102bab - Skeleton Bunk Only



#102- Skeleton Log Car

Truss

- #103 - Truss Log Car Kit
- #103ab - Truss Bunk Only



#103- Truss Log Car

Logging Caboose

- #104 - Logging Caboose Kit



#104- Logging Caboose

Log Load

- LL - Unassembled Log Kit - Requires Painting,



LL- Logs

Kadee® HO-Scale Undecorated & Kit Cars



Kadee® Manufactured
& Assembled in the
U.S.A.



MAGNE-MATIC® COUPLERS
World's Best Magnetic Couplers!

Undecorated Cars & Boxcar Kits

Craftsman Quality detailing engineered throughout the plastic & die-cast metal components, No Glue Required. Equipped with Kadee® Scale Couplers, highly detailed Trucks & RP-25 Wheels, Apex running board, Youngstown doors, highly detailed hand brake, Precision balanced.

Undecorated Cars

Fully Assembled, Painted, Ready to Run.

Boxcar Kits

Require Assembly, Painting & have a partially assembled underframe.

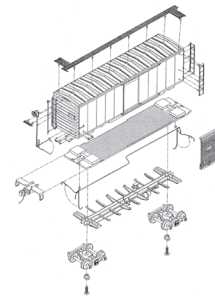

40' PS-1 Boxcars

- #4000 Undecorated 6' Door, Boxcar Red
- #4100 6' Door Boxcar Kit
- #4101 7' Door Boxcar Kit
- #4102 8' Door Boxcar Kit
- #5199 Undecorated 8' Door, Red Oxide
- #5200 Undecorated 8' Door, Boxcar Red



#4100 - 6' Door Boxcar Kit

50' PS-1 Boxcars

- #6000 Undecorated 9' Door, Boxcar Red
- #4105 9' Door Single Door Boxcar Kit
- #4110 15' Door Double Door Boxcar Kit
- #4115 10' Door Hydrocushion Boxcar Kit
- #4116 10' Door Hydrocushion, no roof walk, Boxcar Kit
- #4120 9' Door Hydrocushion, no roof walk Boxcar Kit
- #4121 9' Door Hydrocushion Boxcar Kit - Unpainted



#4115 - 10' Door Hydrocushion Boxcar Kit
Fully Functioning Cushion Underframe

PS-2 Covered Hoppers - 2-Bay

- #8001 Hat Rib - Undecorated Gray
- #8601 Channel Rib - Undecorated Gray



#8001 - PS-2 Covered Hopper

AAR Open Hoppers - 2-Bay

- #7001 Wine Doors - Undecorated Black
- #7002 Wine Doors - Undecorated Boxcar Red
- #7501 Enterprise Doors - Undecorated Black



#7001 - AAR Open Hopper

Patent numbers D 410,709 D 414,533 5,785,192 7,434,518 B1

Kadee® HO-Scale "RTR" Cars

Kadee®

MAGNE-MATIC® COUPLERS

World's Best Magnetic Couplers!

Kadee® Manufactured
& Assembled in the
U.S.A.



Kadee® Cars

Designed, Manufactured & Assembled
entirely in the U.S.A.



40' PS-1 Boxcar



50' PS-1 Boxcar



PS-2 Hopper



Kadee® prides itself in creating and manufacturing premium "RTR" rolling stock as close to scale & detail as possible. Model railroaders can expect only the best quality & craftsmanship with every Kadee® quality product. Nothing stacks up to the accuracy, detail, quality, & authenticity of Kadee® Cars over all other "RTR" cars on the market.

ALL KADEE® HO-SCALE "RTR" CARS ARE STANDARD EQUIPPED WITH:

- Fully Assembled, Ready To Run, Premium freight cars, no glue ever used.
- Kadee® Magne-Matic® "Scale" Metal Couplers with delayed centering action.
- Kadee® smooth rolling, equalized, self-centering trucks with RP-25 non magnetic metal wheels.
- Premium prototypical scale grab irons, ladders, see-through roofwalk, brake wheels & brake rigging etc...
- N.M.R.A. standard weight, low center of gravity for optimum operating performance.
- Accurate legible highly detailed prototypical heralds & lettering.
- Limited production, making them valuable to collectors.
- Now Available 50' Functioning Hydrocushion Cars.

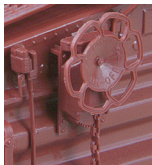

End details include scale incredibly detailed hand brake and rigging.

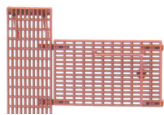

See-through running board and brake step.



Scale rivets, grabs, air lines, chains, & AB valve



Kadee® Functioning Hydrocushion Underframe & Magne-Matic® "Scale" Coupler with patented delayed centering action.



Sharp prototypically accurate legible lettering.



Highly detailed movable doors.



Scale ladders and grab irons.

CNW, DRGW, MKT, MP, SP, SSW, UP, & WP marks are made under trademark license from Union Pacific Railroad Company.

New Roads Released Monthly

Due to Limited Production Runs.

Check the Kadee® Monthly Flyer, Web Site or Call for Current Road Name Availability.

"RTR" Availability Car Styles Include

40' PS-1 Box Cars

6, 7, 8 Foot Doors & Various Side Sills

50' PS-1 Box Cars

8, 9, 10, 15 Foot Doors, Various Side Sills, Stiffeners, & Underframes Including the **Functioning Hydrocushion** Underframe

2-Bay PS-2 Covered Hoppers

Channel & Hat Rib

2-Bay AAR "Standard" Open Hoppers

Wine & Enterprise Doors

ACF 11,000 Gallon Insulated Tank Cars

Step & Full Platform



CALL OR CHECK WEBSITE FOR AVAILABLE CARS, DUE TO LIMITED PRODUCTION RUNS!

Notes:

Kadee® HOn3-Scale



MAGNE-MATIC® COUPLERS
World's Best Magnetic Couplers!

Kadee® Manufactured
& Assembled in the
U.S.A.



Couplers & Coupler Accessories

Body Mount Couplers

2 pair Plastic Coupler, with (#636) Coil Centering Spring, & Draft Gear Box. Same as #711 except with shorter length Trip Pin. (The #702 Coupler Assembly Fixture can be used to ease assembly)

- #713 Plastic - (Rust)
- #714 Plastic - (Black)

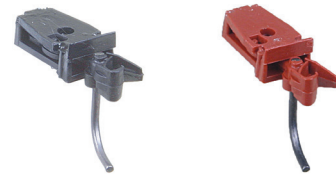

Coupler Height Gauges

Coupler Height Gauge (5 Tools in One)

- 1) Provides instant visual reference of proper coupler height
- 2) Gauges car underbody height from the rail
- 3) Gauges track width
- 4) Gauges wheel width
- 5) Uncoupler gluing jig

- #704 HOn3-Scale Coupler Height Gauge

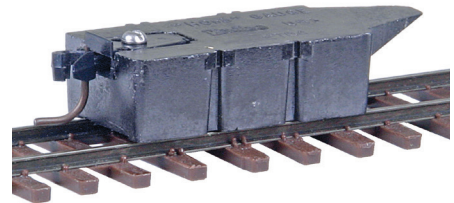

Uncouplers

Delayed Uncouplers (Track Not Included)

- #709 "Between-the-Rails" One Pair

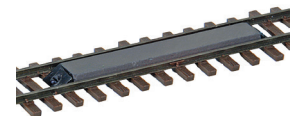

#709 - Between-the-Rails

Electric Delayed Uncoupler (Track Not Included)

- #708 "Thru-the-Track" - Fits codes 70, 60, 55 track & other sizes down as small as code 40. Requires: 8-12 Volt DC

Use (normally open) Momentary Switches with Electric Uncouplers.
Like #163 or #165 Momentary Quickie Switches

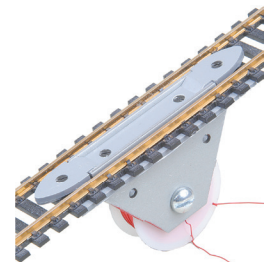

#708 - Between-the-Rails

Momentary Switches

Quickie Control Panel Switches

Single Pole, Single Throw, push button Control Panel Switches with color-coded caps. AC or DC at 3 amp.
Use for uncouplers, turnout motors, etc.

- #163 Black - (normally closed) & Red - (normally open) - 2 each
- #164 Black - (normally closed) - 4 each
- #165 Red - (normally open) - 4 each



Kadee® HOn3-Scale



Kadee® Manufactured
& Assembled in the
U.S.A.



MAGNE-MATIC® COUPLERS
World's Best Magnetic Couplers!

Trucks

Arch Bar Freight Truck

Unassembled Metal Freight Truck with 26" Ribbed back wheels
(Use the #715 HOn3 Truck Assembly Fixture to assist assembly)

- #716 Arch Bar Truck - 3'-7" Wheel Centers
- #717 Arch Bar Truck - 4'-6" Wheel Centers



#716 - 3'-7"
Wheel Centers



#717 - 4'-6"
Wheel Centers

Wheelsets

Freight Wheels (Code 110)

Non Magnetic Free Rolling Contoured Axles with RP-25 Contour Wheels.
Eight Sets

- #718 Freight Wheel Set - 26" Ribbed Back



Springs

Coupler Centering Springs

- #636 For #711, #712, #714, & #715 Couplers



Truck Springs

- #624 For #716, & #717 Trucks

Assembly Fixtures

Coupler Assembly Fixture

Assembly fixtures are innovative tools that will assist you
in assembling the Kadee® Magne-Matic® Couplers.

- #702 For #711, #712, #714, & #715 Couplers

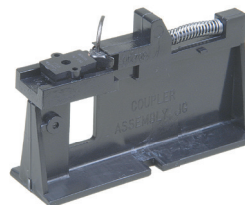

#702 - Coupler
Assembly Fixture

Truck Assembly Fixture

When you buy Kadee® HOn3 Trucks be sure to get this wonderful
"HELPFUL HAND" The Kadee® Truck Assembly Fixture will save
you frustration, lost springs and time.

- #715 - Truck Assembly Fixture

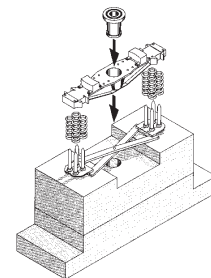
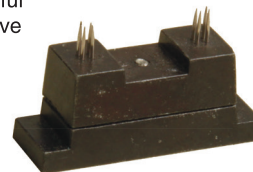

#715 - Truck
Assembly Fixture

Track Gauge

Track Gauge

- #342 For Code 83 & Code 100 Track

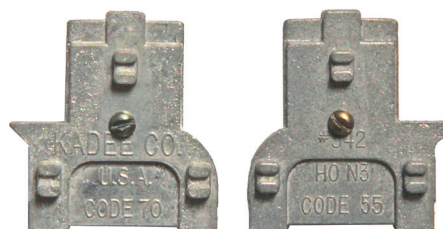

Kadee® S-Scale, On3-Scale, On30-Scale & O-Scale



MAGNE-MATIC® COUPLERS
World's Best Magnetic Couplers!

Kadee® Manufactured
& Assembled in the
U.S.A.



Through



Couplers

S-Scale Couplers

2 pair Plastic Couplers, with (#847) Coil Knuckle Spring, (#846) Coil Centering Spring, & Plastic Draft Gear Boxes.

- #802 Plastic Couplers & Gear Box (Black)
- #808 Plastic Couplers & Gear Box (Brown)

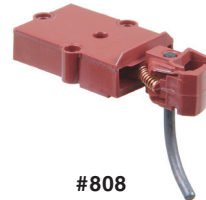

#808



#802

On3-Scale Couplers

2 pair Plastic Couplers, with (#847) Coil Knuckle Spring, (#846) Coil Centering Spring, & Plastic Draft Gear Boxes.

- #803 Plastic Couplers & Gear Box (Black)
- #807 Plastic Couplers & Gear Box (Brown)

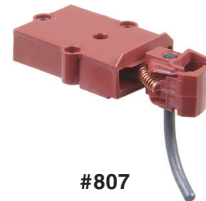

#807



#803

O-Scale Couplers

1 pair Couplers, with (#845) Coil Knuckle Spring, (#850) Coil Centering Spring, & Draft Gear Boxes. Coupler & Draft Gear Box Black unless noted.

- with Metal (#817 type) Draft Gear Box** (same color as coupler)
- #805 Medium Centerset Shank Metal Coupler

- with Plastic #817 Draft Gear Box** (same color as coupler)
- #800 Medium Centerset Shank Plastic Coupler (Rust)
- #801 Medium Centerset Shank Plastic Coupler (Brown)
- #804 Medium Centerset Shank Plastic Coupler
- #816 Medium Centerset Shank Metal Coupler

- with Plastic Short Draft Gear Box** (same color as coupler)
- #806 Short Centerset Shank Plastic Coupler

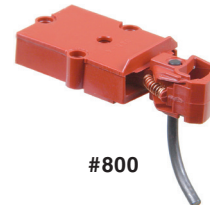

#800

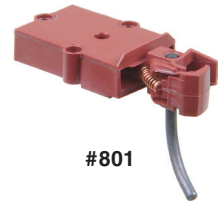

#801

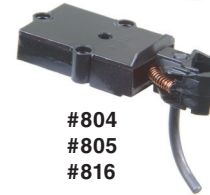

#804
#805
#816

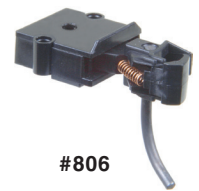

#806

O-Scale Couplers "New Generation"

2 pair Metal Couplers, with hidden Knuckle Spring, (#850) Coil Centering Spring, & Draft Gear Boxes. Coupler & Draft Gear Box Black unless noted.

- with Metal (#817 type) Draft Gear Box** (same color as coupler)
- #740 Medium Centerset Shank Metal Coupler

- with Plastic #817 Draft Gear Box** (same color as coupler)
- #742 Medium Overset Shank Metal Coupler
- #745 Medium Centerset Shank Metal Coupler
- #746 Long Centerset Shank Metal Coupler
- #747 Medium Underset Shank Metal Coupler

- with Plastic Short Draft Gear Box** (same color as coupler)
- #743 Short Centerset Shank Metal Coupler

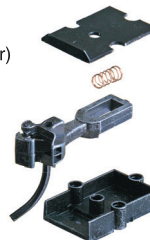

#740
#745



#746



#743



#747



#742

Patent number 7,810,660 B1

Kadee® S-Scale, On3-Scale, On30-Scale, & O-Scale



Through



Kadee® Manufactured
& Assembled in the
U.S.A.



MAGNE-MATIC® COUPLERS
World's Best Magnetic Couplers!

Accessories

Centering Springs

1 Dozen

- #846 For #802, #803, #807 & #808 Couplers.
- #850 For All O-Scale Couplers.



Knuckle Springs

1 Dozen

- #845 For #800, #801, #804, #805 & #816 O-Scale Couplers.
- #847 For #802, #803, #807 & #808 Couplers.



Gear Boxes with Lids

For #742, #745, #746, #747, #804 & #816 O-Scale Couplers.

- #817 Insulated Plastic Gear Boxes & Lids - 5 Pair
- #818 Metal Gear Boxes & Lids - 4 Pair
- #819 Extended Metal Gear Boxes & Lids- 4 Pair

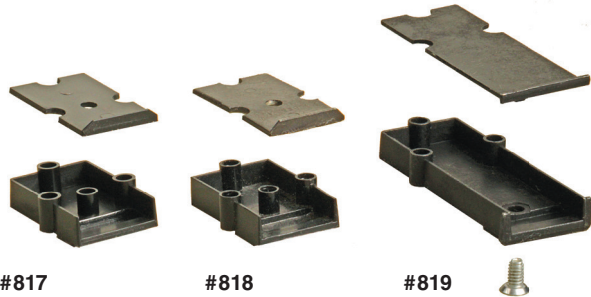

#817

#818

#819

Uncouplers

Delayed Uncouplers (Track Not Included)

- #308 HO thru O-Scale - "Under-the-Track"
Note: O-Scale will require 2-3 magnets stacked together.
- #809 O-Scale 3 Rail - "Between-the-Rails"
- #811 O-Scale - "Between-the-Rails"

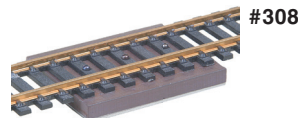

#308

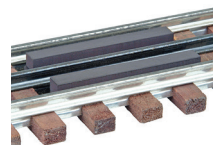

#809

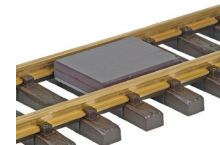

#811

Electric Delayed Uncoupler (Track Not Included)

- #810 O-Scale - "Thru-the-Track" - Fits codes 100, 125, 156, 172 track
Operates: 16 volt DC
We recommend a 16 volt DC power source (at least 2 Amps) or
12-20 volt AC power source (at least 2 Amps) converted to DC with bridge rectifier.

#166 Transformer meets AC power conversion requirements*.
*Additional components required for AC to DC Conversion.
Only use (normally open) Momentary Switches with Electric Uncouplers.
Like #165 Momentary Quickie Switches.

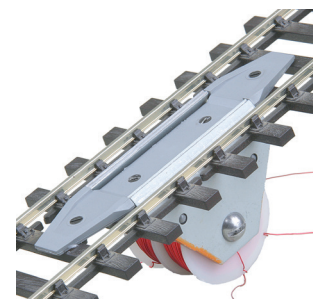
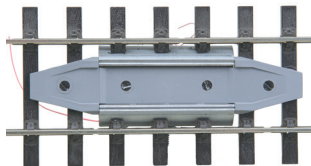

#810

WARNING: Do not use the uncoupler continually. **DO NOT activate the uncoupler for longer than 3 MINUTES at one time.** This will avoid possible overheating which will damage the uncoupler.

Kadee® S-Scale, On3-Scale, On30-Scale, & O-Scale



MAGNE-MATIC® COUPLERS
World's Best Magnetic Couplers!

Kadee® Manufactured
& Assembled in the
U.S.A.



Through



Momentary Switches

Quickie Control Panel Switches

Single Pole, Single Throw, push button Control Panel Switches with color-coded caps. AC or DC at 3 amp.
Use for uncouplers, turnout motors, etc.

- #163 Black - (normally closed) & Red - (normally open) - 2 each
- #164 Black - (normally closed) - 4 each
- #165 Red - (normally open) - 4 each



Transformer

Plug-in Transformer

For use with Kadee® #309 & #810 Electric Uncouplers, Lighting, Motors, Switches, Accessories, Etc.

- #166 INPUT: 120VAC 60Hz 0.50A OUTPUT: 16.5VAC 50VA



Coupler Height Gauges

5 to 6 Tools in One

- 1) Provides instant visual reference of proper coupler height
- 2) Gauges car underbody height from the rail
- 3) Gauges track width (N.M.R.A. Standard)
- 4) Gauges wheel width (N.M.R.A. Standard)
- 5) Gauges proper height of trip pin
- 6) #811 Uncoupler Mounting Jig (#812 Only)

- #812 O-Scale Coupler Height Gauge
- #813 On3-Scale Coupler Height Gauge
- #814 S-Scale Coupler Height Gauge

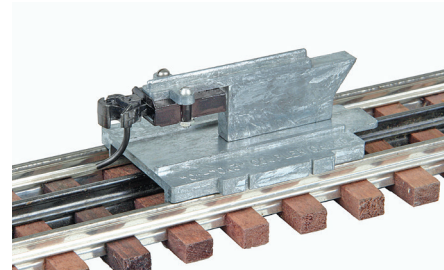

#812

4 Tools in One

- 1) Provides instant visual reference of proper coupler height
- 2) Accurately measures proper trip pin height above the rail
- 3) Built-in track gauge (N.M.R.A. Standard)
- 4) Moveable dowel tests Kadee® Magne-Matic® Uncoupler height and registers the needed adjustments

- #815 On30-Scale Coupler Height Gauge with On3 Coupler

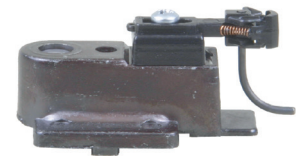

#815

Wheelsets

On30 Freight Wheels

Eight Sets, Non Magnetic Free Rolling Contoured Axles with RP-25 Contour Wheels.

- #300 24" Griffin Ribbed Back



#300

Kadee® S-Scale, On3-Scale, On30-Scale, & O-Scale



Through



Kadee® Manufactured
& Assembled in the
U.S.A.



MAGNE-MATIC® COUPLERS
World's Best Magnetic Couplers!



**AAR
TYPE "E"
O-SCALE
COUPLERS**

#740 Coupler

Patent number 7,810,660 B1



**ORIGINAL
STYLE
O-SCALE
COUPLERS**

#805 Coupler

Kadee® #1-Scale (1:32) & G-Scale (1:22.5)



MAGNE-MATIC® COUPLERS
World's Best Magnetic Couplers!

Kadee® Manufactured
& Assembled in the
U.S.A.



Couplers Only

#1-SCALE (1:32)

G-SCALE (1:22.5)

Straight Centerset Couplers

- #1900 #1-Scale (AAR Type "E" Coupler) Black
- #1900R #1-Scale (AAR Type "E" Coupler) Rust
- #900 G-Scale (AAR Type "E" Coupler) Black
- #900R G-Scale (AAR Type "E" Coupler) Rust

ORIGINAL
STYLE

AAR
TYPE "E"

ORIGINAL
STYLE

AAR
TYPE "E"



*

*

In #820 / #920 Kits Only

#1900 Black, #1900R Rust

In #830 / #930 Kits Only

#900 Black, #900R Rust

Centerset Couplers

- #1840 #1-Scale (Original Style)
- #1901 #1-Scale (AAR Type "E" Coupler)
- #1850 G-Scale (Original Style)
- #901 G-Scale (AAR Type "E" Coupler)



#1840

#1901

#1850

#901

Medium Offset Couplers

- #1838 #1-Scale (Original Style)
- #1902 #1-Scale (AAR Type "E" Coupler)
- #902 G-Scale (AAR Type "E" Couplers)



#1838

#1902

*
In Kits Only

#902

Large Offset Couplers

- #1839 #1-Scale (Original Style)
- #1903 #1-Scale (AAR Type "E" Coupler)
- #903 G-Scale (AAR Type "E" Couplers)



#1839

#1903

*
In Kits Only

#903

Bachmann® Shank Couplers

- #1916 #1-Scale (AAR Type "E" Coupler)
- #916 G-Scale (AAR Type "E" Couplers)



#1916

#916

Straight Shank Couplers

Stationary Mounting

- #822 #1-Scale (Original Style)
- #1904 #1-Scale (AAR Type "E" Coupler)
- #904 G-Scale (AAR Type "E" Couplers)



#822

#1904

#904

Straight Thick Shank Couplers

Stationary Mounting

- #823 #1-Scale (Original Style)



#823

Centerset Short Couplers

Not Sold Separately



*
In #821 / #921 Kits Only



*
In #1917 Kits Only

* Not Sold Separately

Patent number 7,810,660 B1

Kadee® #1-Scale (1:32) & G-Scale (1:22.5)



Kadee® Manufactured
& Assembled in the
U.S.A.



MAGNE-MATIC® COUPLERS
World's Best Magnetic Couplers!

Gear Boxes Only

Standard Body Mount Gear Boxes

Draft Gear Box Black unless noted

- #1920 #1-Scale (#820 type) Body Mount Gear Box
- #1920R #1-Scale (#920 type) Body Mount Gear Box (Rust)
- #910 G-Scale (#830 type) Body Mount Gear Box
- #910R G-Scale (#930 type) Body Mount Gear Box (Rust)



#1920
Standard Body
Mount Gear Box



#910
Standard Body
Mount Gear Box

Truck Mount Gear Boxes

for #1 & G-Scale Centerset, Medium Offset, Large Offset Couplers.

- #911 #1 & G-Scale (#831 type) Truck Mount Gear Box



#911
Truck Mount
Gear Box

Short Body Mount Gear Boxes

for #1 & G-Scale Centerset, Medium Offset, Large Offset Couplers.

- #912 #1 & G-Scale (#835 type) Short Body Mount Gear Box



#912
Short Body Mount
Gear Box

Swinging Gear Boxes

for #1 & G-Scale Centerset, Medium Offset, Large Offset Couplers.

- #913 #1 & G-Scale (#832 type) Swinging Gear Box



#913
Swinging Gear
Box

#791 & #911 Gear Boxes

#1 & G Scale #791 Gear Box for Centerset, Couplers. #911 Gear Box for Centerset, Medium Offset, Large Offset Couplers.

- #915 #1 & G-Scale Mixed Style Gear Box



#791 Pilot Pocket



#911
Truck Mount Gear Box

Gear Boxes Not Sold Separately



#779
Coupler
Sill Mount Pocket
Not Sold as
Gear Box Only



#821 or #921
Coupler
Extra Short Body Mount
Gear Box
Not Sold as
Gear Box Only

Springs

Centering Springs 1 doz unless noted

- #861 for all #1 & G-Scale Couplers, except #820, 821, 830, 900, 906, 920, 921, 930, 1900, 1906, 1917 & 11115
- #876 for #820 or 920 #1-Scale Couplers
- #877 for #821, 921, 1917 #1-Scale Couplers
- #878 for #830, 930, 900, 906, 11115 G-Scale Couplers
- #879 for #820, 920, 1900, 1906 #1-Scale Couplers

Knuckle Springs 1 doz unless noted

Note: All Type "E" Couplers don't have replaceable Knuckle Springs.

- #860 for all G-Scale Couplers. Except Type "E" Couplers
- #875 for #1-Scale Couplers #820 through 828, 920 & 921
- #1875 for #1-Scale Couplers 1700 & 1800 Series



Truck Springs 1 doz unless noted

- #839 Truck Centering Springs & Retainers, for LGB 2-axle cars - 2pr.
- #864 Truck Centering Springs, for LGB 2-axle cars

Kadee® #1-Scale (1:32) & G-Scale (1:22.5)



MAGNE-MATIC® COUPLERS
World's Best Magnetic Couplers!

Kadee® Manufactured
& Assembled in the
U.S.A.



**AAR
TYPE "E"
G-SCALE
COUPLERS**

#900 Coupler

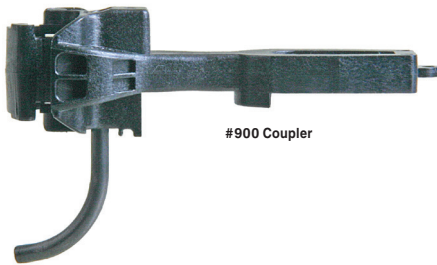

Patent number 7,810,660 B1



**ORIGINAL
STYLE
G-SCALE
COUPLERS**

#830 Coupler

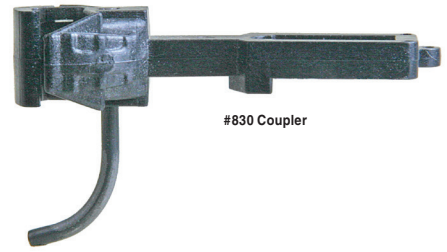

Older Style Couplers: (on this page)

1 pair Couplers, with (#1875 #1-Scale, #860 G-Scale) Coil Knuckle Spring, (#861) Coil Centering Spring, & Draft Gear Boxes.

AAR Type "E" Couplers: (on this page)

1 pair Couplers, with Coil Knuckle Spring, (#861) Coil Centering Spring, & Draft Gear Boxes.

Couplers & #911 Gear Boxes (Truck Mount)

#911 Gear Box:

Truck Mount Gear Box
(1 7/32" long x 25/32" wide x 3/8" high)

Centerset Couplers

- #1789 #1-Scale (Original Style)
- #1907 #1-Scale (AAR Type "E" Coupler)
- #789 G-Scale (Original Style)
- #907 G-Scale (AAR Type "E" Coupler)

Medium Offset Couplers

- #1787 #1-Scale (Original Style)
- #1908 #1-Scale (AAR Type "E" Coupler)
- #787 G-Scale (Original Style)
- #908 G-Scale (AAR Type "E" Couplers)

Large Offset Couplers

- #1831 #1-Scale (Original Style)
- #1909 #1-Scale (AAR Type "E" Coupler)
- #831 G-Scale (Original Style)
- #909 G-Scale (AAR Type "E" Couplers)

#1-Scale



Centerset



Medium Offset



Large Offset



#911
Truck Mount
Gear Box

G-Scale

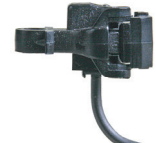

Centerset



Medium Offset



Large Offset

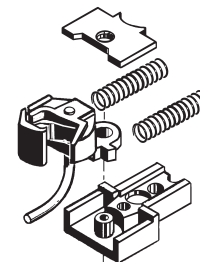

Exploded View

Patent number 7,810,660 B1

Kadee® #1-Scale (1:32) & G-Scale (1:22.5)



Kadee® Manufactured
& Assembled in the
U.S.A.



MAGNE-MATIC® COUPLERS
World's Best Magnetic Couplers!

Older Style Couplers: (on this page)

1 pair Couplers, with (#1875 #1-Scale, #860 G-Scale) Coil Knuckle Spring, (#861) Coil Centering Spring, & Draft Gear Boxes.

AAR Type "E" Couplers: (on this page)

1 pair Couplers, with Coil Knuckle Spring, (#861) Coil Centering Spring, & Draft Gear Boxes.

Couplers & #912 Gear Boxes (Body Mount)

#912 Gear Box:

Short Gear Box
(9/16" long x 13/16" wide x 3/8" high)

Centerset Couplers

#1835 #1-Scale (Original Style)
#835 G-Scale (Original Style)

Medium Offset Couplers

#1836 #1-Scale (Original Style)
#836 G-Scale (Original Style)

Large Offset Couplers

#1837 #1-Scale (Original Style)
#837 G-Scale (Original Style)

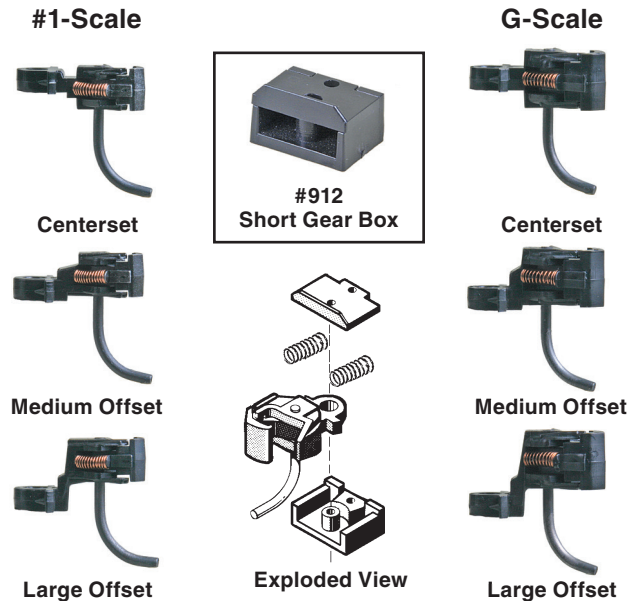

Couplers & #913 Gear Boxes (Body Mount)

Older Style Couplers:

1 pair Couplers, with (#1875 #1-Scale, #860 G-Scale) Coil Knuckle Spring, (#861) Coil Centering Spring, & (#913) Draft Gear Boxes.

#913 Gear Box:

Swinging Gear Box

Large Offset Couplers

#1832 #1-Scale (Original Style)
#832 G-Scale (Original Style)

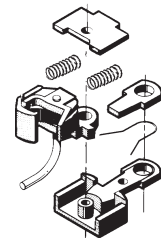

Exploded View



Couplers & Extra Short Gear Boxes

Extra Short Gear Box:

(1 7/32" long x 25/32" wide x 3/8" high)

Centerset Couplers

Centerset Short Shank Couplers with Extra Short Gear Boxes.

#821 #1-Scale (Original Style)
#921 #1-Scale (Original Style) (Rust)
#1917 #1-Scale (AAR Type "E" Coupler)

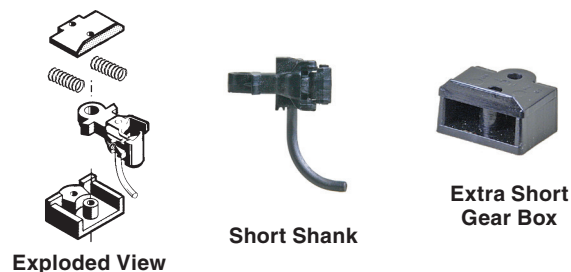

Patent number 7,810,660 B1

Kadee® #1-Scale (1:32) & G-Scale (1:22.5)



MAGNE-MATIC® COUPLERS
World's Best Magnetic Couplers!

Kadee® Manufactured
& Assembled in the
U.S.A.



Couplers & Standard #910 or #1920 Gear Boxes (Body Mount)

Older Style Couplers:

1 pair Couplers, with (#875 #1-Scale, #860 G-Scale) Coil Knuckle Spring, (#879 #1-Scale, #878 G-Scale) Coil Centering Spring, & (#1920 #1-Scale, #910 G-Scale) Draft Gear Boxes.

AAR Type "E" Couplers:

1 pair Couplers, with Coil Knuckle Spring, (#879 #1-Scale, #878 G-Scale) Coil Centering Spring, & (#1920 #1-Scale, #910 G-Scale) Draft Gear Boxes.

#1920 #1-Scale Gear Box:

Standard Gear Box (1 1/4" long x 7/8" wide x 5/16" high)

#910 G-Scale Gear Box:

Standard Gear Box (1 21/32" long x 1 5/32" wide x 13/32" high)

Centerset Couplers

Coupler & Draft Gear Box Black unless noted.

with #1920 Draft Gear Box (same color as coupler)

- #820 #1-Scale (Original Style)
- #920 #1-Scale (Original Style) (Rust)
- #1906 #1-Scale (AAR Type "E" Couplers)
- #1906R #1-Scale (AAR Type "E" Couplers) (Rust)

with #910 Draft Gear Box (same color as coupler)

- #830 G-Scale (Original Style)
- #930 G-Scale (Original Style) (Rust)
- #906 G-Scale (AAR Type "E" Couplers)
- #906R G-Scale (AAR Type "E" Couplers) (Rust)

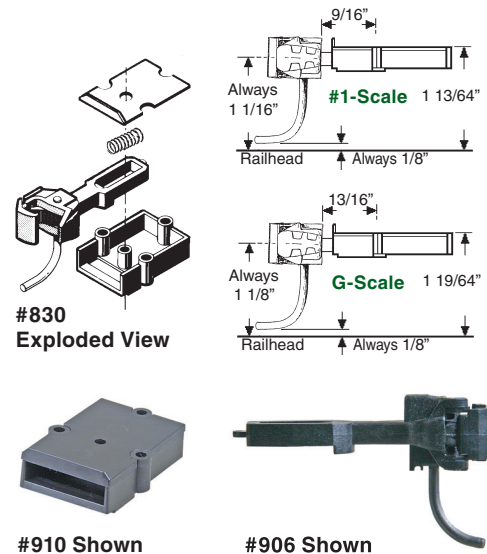

Coupler Conversion Kits

Coupler Conversion Kits

1 pair Original Style Couplers & Draft Gear Boxes. NOTE: Packaging descriptions below do not include miscellaneous shims, brackets, screws, etc. that may be included in packages. Couplers & or Draft Gear Boxes may have to be modified from their original state for the conversions.

Use the #1 & G-Scale Coupler Conversion List to choose appropriate coupler for Locomotive or Rolling Stock.

(Original Style Couplers)

| #1-Scale | G-Scale | |
|----------|---------|---|
| #1781 | #781 | Centerset Coupler & Medium Offset Coupler with Pilot Pocket Gear Box & Truck Mount Type Gear box. |
| #1782 | #783 | Cut Couplers with Mounting Brackets. |
| #1783 | #783 | Cut Coupler with Mounting Bracket & Large Offset Coupler with Truck Mount Type Gear box. |
| #1784 | ----- | Large Offset Couplers with Truck Mount Type Gear boxes. |
| #1785 | #785 | Large Offset Couplers with Truck Mount Type Gear boxes. |
| #1786 | #786 | Medium Offset Couplers with Swinging Type Gear boxes. |
| #1788 | #788 | Medium Offset Couplers with Truck Mount Type Gear boxes. |
| #1790 | #790 | Large Offset Coupler & Modified Medium Offset Coupler with Truck Mount Type Gear boxes. |
| #1792 | #792 | Large Offset Couplers with Truck Mount Type Gear boxes. |
| #1793 | #793 | Large Offset Coupler & Medium Offset Coupler with Truck Mount Type Gear boxes. |
| #1798 | #798 | Large Offset Couplers with Truck Mount Type Gear boxes. |
| #1799 | #799 | Large Offset Couplers with Truck Mount Type Gear boxes. |
| #824 | ----- | Straight Centerset Shank Couplers with Standard Gear boxes. |
| #827 | ----- | Straight Thick Shank Type Coupler & Centerset Short Shank Coupler with Extra Short Gear box. |
| #1833 | #833 | Large Offset Couplers with Truck Mount Type Gear boxes. |
| | | |
| | | |

Kadee® #1-Scale (1:32) & G-Scale (1:22.5)



Kadee® Manufactured
& Assembled in the
U.S.A.



MAGNE-MATIC® COUPLERS
World's Best Magnetic Couplers!

Flex-brackets

Flex-brackets only

#1-Scale (1 Pair)

#882 for #1 Scale #820, #920 or #1906 Couplers

G-Scale (1 Pair)

#883 for #1 Scale #830, #930 or #906 Couplers

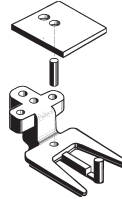

#882

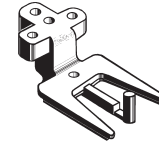

#883

Conversion Platforms

Conversion Platforms only

#1-Scale & G-Scale (1 Pair)

#881 for mounting #882 & #883 Flex-brackets on Aristo-Craft™ Heavyweight Passenger Car

#884 for mounting #820, #830, #920, #930, #906 or #1906 Couplers on Aristo-Craft™ GE U-25B

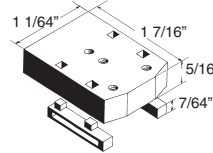

#881

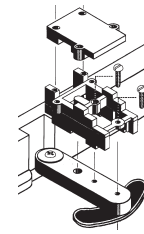

#884

Body Mount Shims

G-Scale Body Mount Shims

G-Scale (8 Each)

Shims 1/16" & 1/32" thick.

For the #910 gear box used on the #830, #930 & 906 Couplers.

#841 Black
#941 Boxcar Red



Uncouplers

Delayed Uncouplers (Track Not Included)

1 per package

#842 Unmounted
#844 Portable

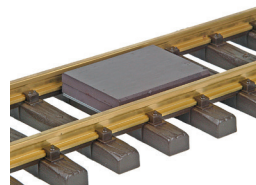

#842

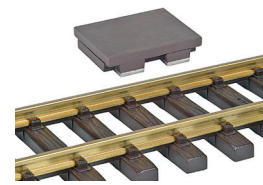

#844

Coupler Height Gauges

5 Tools in One

- 1) Provides instant visual reference of proper coupler height
- 2) Gauges car underbody height from the rail
- 3) Gauges track width (N.M.R.A. Standard)
- 4) Gauges wheel width (N.M.R.A. Standard)
- 5) Gauges proper height of trip pin

#829 #1-Scale (Original Style) Coupler Height Gauge
#1929 #1-Scale (AAR Type "E") Coupler Height Gauge
#880 G-Scale (Original Style) Coupler Height Gauge
#980 G-Scale (AAR Type "E") Coupler Height Gauge

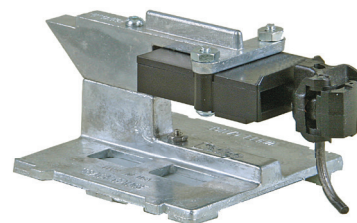

#980 Shown



MAGNE-MATIC® COUPLERS
World's Best Magnetic Couplers!

Kadee® Manufactured
 & Assembled in the
 U.S.A.



Wheelsets

The terms "Large Scale" refers to #1 (1:32 ratio) up to Fn3 (1:20.3 ratio). All of these scales run on the common 45 mm gauge track, which is actually #1 scale standard gauge track. This is considered narrow gauge track for the other large scales. Unfortunately, all of these Large Scales are generally referred to as "G" gauge or "G" Scale modeling. In fact G-Scale is the ratios of 1:24 (1/2") and 1:22.5.

Kadee® New "Large Scale" Freight or Passenger Wheels come in a 33" (1:29) wheel that happens to be the same as 36" (1:32) wheel. The Kadee® wheels sets will work in most manufactures truck journals. This is because of the different actual scale ratios, that Large Scale manufactures use, changing wheels may alter coupler heights. So when you change wheels or trucks always re-check the coupler heights with our Large Scale height gauge. When using Kadee® couplers it's important to make sure all your couplers are at the correct coupler height.

Uncolored Large Scale Wheelsets

**Uncolored Metal Wheels- Freight or Passenger
 1:29 Scale 33" Wheels / 1:32 Scale 36" Wheels**

- #950 Uncolored Metal Wheels (Smooth)
- #951 Uncolored Metal Wheels (Ribbed)



#950



#951

Black Large Scale Wheelsets

**Black Metal Wheels- Freight or Passenger
 1:29 Scale 33" Wheels / 1:32 Scale 36" Wheels**

- #960 Black Metal Wheels (Smooth)
- #961 Black Metal Wheels (Ribbed)



#960



#961

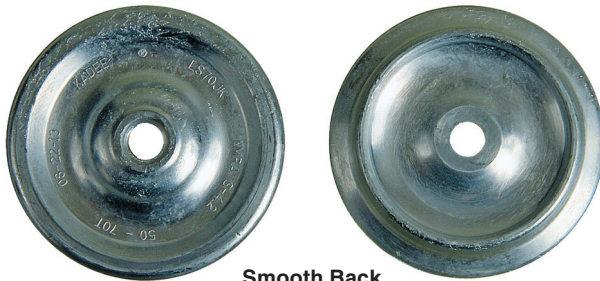

Smooth Back



Ribbed Back



Kadee® Manufactured
& Assembled in the
U.S.A.



MAGNE-MATIC® COUPLERS
World's Best Magnetic Couplers!

Trucks

The terms "Large Scale" refers to #1 (1:32 ratio) up to Fn3 (1:20.3 ratio). All of these scales run on the common 45 mm gauge track, which is actually #1 scale standard gauge track. This is considered narrow gauge track for the other large scales. Unfortunately, all of these Large Scales are generally referred to as "G" gauge or "G" Scale modeling. In fact G-Scale is the ratios of 1:24 (1/2") and 1:22.5.

Large Scale 1:29 Scale Ratio Metal Trucks

1 Pair 1:29 Scale Metal Trucks.

- All Metal Non-Magnetic 2 Piece Self Equalizing design.
- All Metal Non-Magnetic Wheels with Free Rolling Insulated Axles.
- Clip on pads & brake rigging.
- Mounting adapters for Bachmann, USA Trains, Aristo-Craft, Peco & LGB are included.

- | | |
|------|-----------------------------------|
| #970 | A.S.F® A-3 Ride-Control® 50-Ton |
| #971 | A.S.F® Bettendorf style 50-Ton |
| #972 | Arch Bar |
| #973 | Barber® S-2 Roller bearing 70-Ton |
| #974 | A.S.F® 100-Ton Roller bearing |

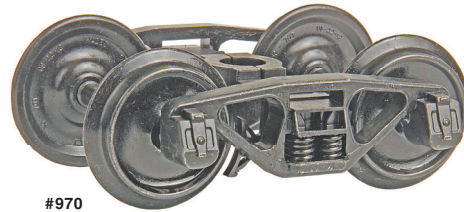

#970

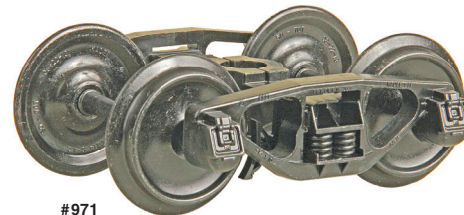

#971

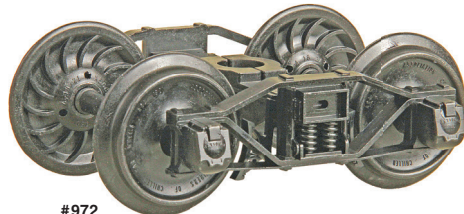

#972

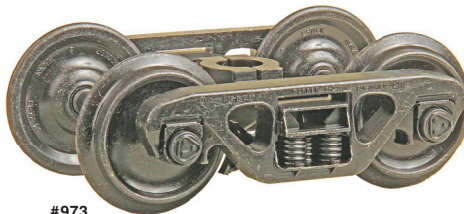

#973

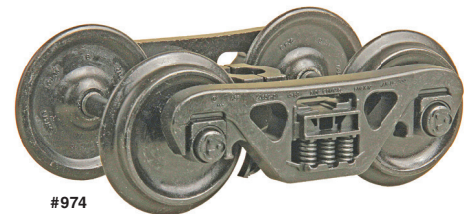

#974



MAGNE-MATIC® COUPLERS
World's Best Magnetic Couplers!

Kadee® Manufactured
& Assembled in the
U.S.A.



Notes:

Kadee® RC Remote Couplers

We recommend operating Kadee® RC Remote Couplers using the Kadee® RC Remote System, other means of operating & controlling the standard hobby servos can be used with Kadee® RC Remote Couplers, as long as the degree of servo rotation is adjustable. The Kadee® RC Remote Couplers are designed to operate with 90 degree servo rotation only.

| | | | | |
|-------|--|-------|--|--|
| 11115 | | | | Body Mount Coupler Kit (1 Kit) |
| | | | | Includes: 2 - #906 Individual Couplers & Body Mount Gearboxes, 2 - Trip Pin Linkage Collars, 2 - Short Linkage Rods, 1 - Long Linkage Rod, 2 - #841 Shims, 1 - Mounting Screws & Hardware, 1 - Standard Servo Kit #11120 |
| 11220 | | 11221 | | Actuated Body Mount Coupler with Gearbox (1 Kit) |
| | | | | Includes: 1 - Actuated Body Mount Coupler with Gearbox - Assembled |

Couplers Only

| | | | | |
|----------|------|------------|------|---|
| 904 | | 1904 | 822 | Straight Shank Couplers Stationary Mounting (1 Pair) |
| 900/900R | | | 823 | Straight Thick Shank Couplers Stationary Mounting (1 Pair) |
| | | 1900/1900R | | Straight Centerset Shank AAR Type "E" Couplers (1 Pair) |
| 901 | 1850 | 1901 | 1840 | Centerset Couplers (AAR Type "E" Couplers (1 Pair)) ("Older Style" Couplers (2 Pair)) |
| 902 | | 1902 | 1838 | Medium Offset Couplers (AAR Type "E" Couplers (1 Pair)) ("Older Style" Couplers (2 Pair)) |
| 903 | | 1903 | 1839 | Large Offset Couplers (AAR Type "E" Couplers (1 Pair)) ("Older Style" Couplers (2 Pair)) |
| 916 | | 1916 | | Bachmann® Shank AAR Type "E" Couplers (1 Pair) |



Gearboxes, Flex-brackets & Conversion Platforms

| | | | | |
|----------|-----|------------|-----|---|
| | | | | |
| | | | 828 | Long Flex-brackets & #820 Couplers (1 Pair) |
| | | | 882 | Flex-brackets for #1 Scale #820, #920 or #1906 Couplers (1 Pair) |
| | 838 | | | #883 Flex-brackets & #830 Couplers (1 Pair) |
| | 883 | | | Flex-brackets for G Scale #830, #930 or #906 Couplers (1 Pair) |
| | 881 | | | Conversion Platforms for #1 & G Scale mounting #838, #882 or #883 Flex-brackets & Couplers on Aristo-Craft™ Heavyweight Passenger Car (1 Pair) |
| | 884 | | | Conversion Platforms for #1 & G Scale mounting #820, #830, #930, #906 or #1906 Couplers on Aristo-Craft™ GE U-25B (1 Pair) |
| 910/910R | | | | #830 (type) Body Mount Gear Boxes for G-Scale Straight Centerset Shank Couplers. #900 AAR Type "E" Couplers (1 Pair) |
| | 911 | | | #831 (type) Truck Mount Gear Boxes for #1 & G Scale Centerset, Medium Offset, Large Offset Couplers. (1 Pair) |
| | 912 | | | #835 (type) Short Body Mount Gear Boxes for #1 & G Scale Centerset, Medium Offset, Large Offset Couplers. (1 Pair) |
| | 913 | | | #832 (type) Swinging Gear Boxes for #1 & G Scale Centerset, Medium Offset, Large Offset Couplers. (1 Pair) |
| | 915 | | | #791 Pilot Pocket & #911 #831 (type) Truck Mount Gear Boxes #1 & G Scale #791 for Centerset, Couplers. #831 for Centerset, Medium Offset, Large Offset Couplers. (1 Each) |
| | | 1920/1920R | | #820 (type) Body Mount Gear Boxes for #1-Scale Straight Centerset Shank Couplers. #1900 AAR Type "E" Couplers (1 Pair) |

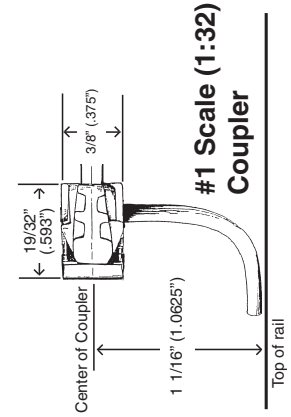
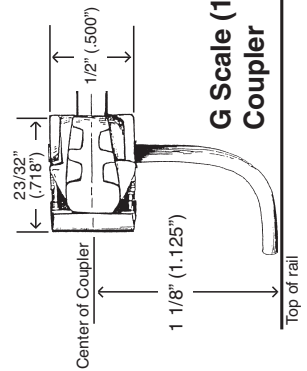
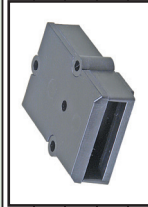



Kadee® Manufactured
& Assembled in the
U.S.A.



Kadee
MAGNE-MATIC® COUPLERS
World's Best Magnetic Couplers!

Notes:

Tools

Adaptor Insertion Pic

#230 For 20-Series #212 Talgo-Truck Adaptors



“Greas-em” Dry Graphite Lubricant

#231 This fine, dry graphite lubricant is specially selected for use with Kadee® Couplers. Add a puff inside your couplers, move them back-and-forth a few times to burnish the insides, and enjoy smooth action of your couplers. Also an excellent general purpose lubricant for use all around the layout to reduce friction in moving parts & bearing surfaces.



5.5 grams

“Speedi” Driver Cleaner

“Speedi” Driver Cleaners are easy to use and efficient. Just hook the power leads to a 12 volt DC source and touch the brushes against the driving wheels of your locomotive.

#236 HOn3 to O-Scale
#843 O to G-Scale

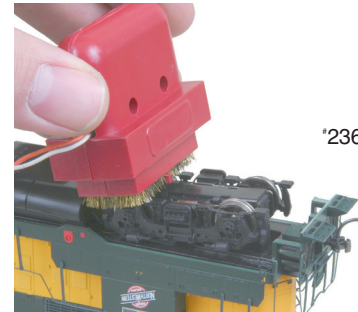

#236 Shown

Coupler Trip Pin Pliers

#237 For HO, HOn3, S, On3 & O Scale Couplers. Adjust trip pin to the correct height by gently squeezing with these specially designed pliers. The pliers have jaw surfaces that are curved and smooth. Adjusting the height of your Coupler Trip Pins is easier because the pliers surfaces conform to the bend of the trip pins and prevent them from kinking when bending or straightening.



TO BEND DOWN



TO BEND UP

5 Prong “Gripper”

#239 For handling small parts. This tool can help with difficult modeling chores. 5-prongs for grabbing, picking, pulling, lifting, and placing those small, difficult-to-grasp items.



Pin Vise

#240 Double headed Pin Vise with two reversible collets. Used for tapping and drilling.



Tools

“Dual Tool”

#241 Manual uncoupling tool & Spring Pic “Dual TOOL”

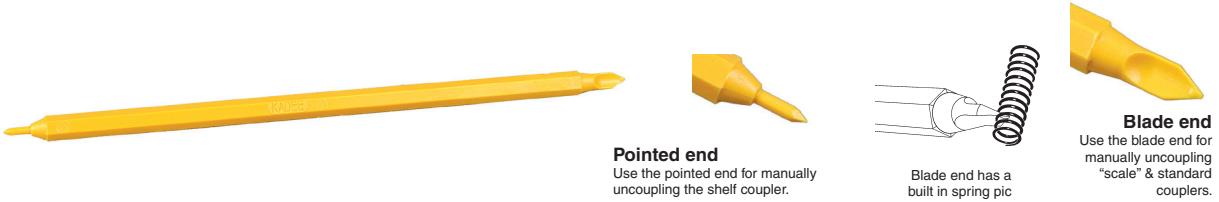

Tap & Drill Sets

WARNING: Cutting tools may shatter when broken. An approved form of eye protection is strongly recommended. Each set includes - Tap, Tap Drill and Clearance Drill

- #246 2-56 Tap + #50 & #43 Drills
- #247 1-72 Tap + #53 & #48 Drills
- #780 0-80 Tap + #55 & #52 Drills
- #1059 00-90 Tap + #62 & #56 Drills

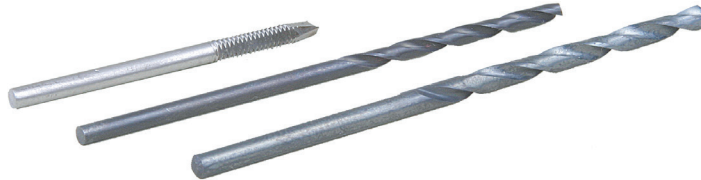

Track Gauges

- #341 For Code 70 & Code 100 Track (HO)
- #342 For Code 55 66 and 70 (HO_n3)
- #343 For Code 83 & Code 100 Track (HO)

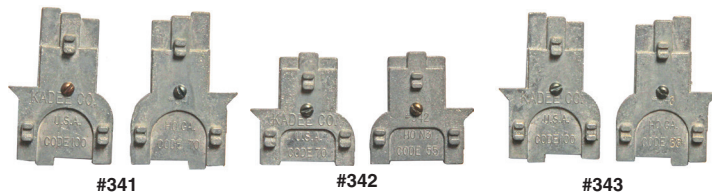

Coupler Assembly Fixture

Assembly fixtures are innovative tools that will assist you in assembling the Kadee® Magne-Matic® Couplers.

- #701 For #4, #5, #9, #43, #46 & #58 Couplers
- #702 For #711, #712, #713 & #714 Couplers
- #703 For #6, #7 & #8 Couplers

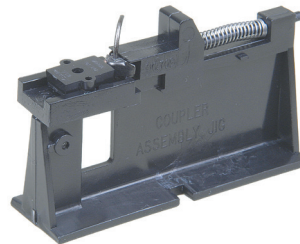

Coupler and Special Purpose Tweezers

#1020 - These tweezers are specially designed to hold Kadee® coupler shanks for easy installation of couplers and springs into draft gear boxes. Also great for many other uses around the layout.



Decal Paper, Momentary Switches, Transformer

Decal Paper

Store decals & decal paper flat in a cool dry place. Avoid exposure to heat, sun light, & moisture.

Application Instructions:

Don't leave in dish of water for more than 1 min. to avoid decal separating from backing in dish.

Cut out decal as close to lettering as your comfortable with, dip decal in clean water for about 10-15 sec. and remove. Place on wet cloth for 90+ sec., decal should now slide from backing easily.

Hold decal in desired location on model and slide backing away.

With a small soft wet paint brush you may fine-tune positioning.
Keep decal wet.

Gently dab/blot with a towel to remove extra water and allow to dry.

Test finishing solutions before applying to entire decal.

Clear Decal Paper

For use with ALPS printers, most laser printers, and color copiers. Before making multiple copies, always check to make sure the paper is compatible with the printer or copier you are using.

- #3098 8-1/2 x 11 Clear (5) Sheets
- #3099 8-1/2 x 11 Clear (1) Sheet

Street Marking Decals

- #3123 Dash - Yellow
- #3124 Solid/Dash - Yellow
- #3125 Solid/Solid - White
- #3126 Solid/Solid - Yellow

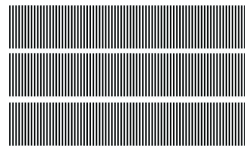

Dash

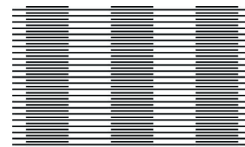

Solid /Dash



Solid/Solid

Hopper Decals

- #3121 CG - Black Lettering

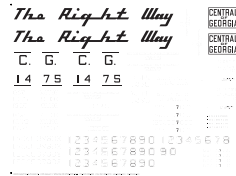

Momentary Switches

Quickie Control Panel Switches

Single Pole, Single Throw, push button Control Panel Switches with color-coded caps. AC or DC at 3 amp. Use for uncouplers, turnout motors, etc.

- #163 Black - (normally closed) & Red - (normally open) - 2 each
- #164 Black - (normally closed) - 4 each
- #165 Red - (normally open) - 4 each



Transformer

Plug-in Transformer

For use with Kadee® #309 & #810 Electric Uncouplers, Accessories, Etc.

- #166 INPUT: 120VAC 60Hz OUTPUT: 18VAC 40VA 2.2A



Screws, Washers & Nuts

Fiber Washers

Fiber Washers Four Dozen

- #208 Red .015" Thick (1/4" O.D. x 1/8" I.D.)
- #209 Gray .010" Thick (1/4" O.D. x 1/8" I.D.)



Plastic Washers

Plastic Washers Two Dozen

Included in 30 Series Couplers.

- #210 1/32" Thick (5/32" O.D. x 5/64" I.D.)



Insulated Nylon Screws

2-56 Insulated Screws One Dozen

- #256 2-56 x 1/2" Long



Metal Screws

0-48 Screws Two Dozen

- #400 0-48 x 1/8" Long
- #401 0-48 x 3/16" Long
- #402 0-48 x 1/4" Long
- #403 0-48 x 3/8" Long



Stainless Steel Screws

2-56 Screws One Dozen

- #1703 2-56 x 1/8" Long
- #1706 2-56 x 1/4" Long
- #1708 2-56 x 3/8" Long
- #1709 2-56 x 1/2" Long
- #1710 2-56 x 5/8" Long
- #1711 2-56 x 3/4" Long

1-72 Screws One Dozen

- #1683 1-72 x 1/8" Long
- #1686 1-72 x 1/4" Long
- #1688 1-72 x 3/8" Long
- #1689 1-72 x 1/2" Long

0-80 Screws One Dozen

- #1643 1-72 x 1/8" Long
- #1646 1-72 x 1/4" Long
- #1648 1-72 x 3/8" Long
- #1649 1-72 x 1/2" Long



Stainless Steel Washers

2-56 Washers One Dozen

- #1701 2-56 Washer

1-72 Washers One Dozen

- #1681 1-72 Washer

0-80 Washers One Dozen

- #1641 1-72 Washer



Stainless Steel Nuts

2-56 Nuts One Dozen

- #1700 - 2-56 Nut

1-72 Nuts One Dozen

- #1680 - 1-72 Nut

0-80 Nuts One Dozen

- #1640 - 1-72 Nut



Storage

Plastic Storage Boxes

Clear plastic storage boxes. 3000, 3010, 3011, 3012, 3013, 3014 are also listed on page HO - 11
(One Each unless noted)

- #3000 Plastic Box only
- #3010 Plastic Box with 40 Ft. Boxcar nest
- #3011 Plastic Box with 50 Ft. Boxcar nest
- #3012 Plastic Box with Covered Hopper nest
- #3013 Plastic Box with Open Bay Hopper nest
- #3014 Plastic Box with Tank Car nest
- #3020 Medium Plastic Jewel Storage Boxes - 2.56 x 2.56 x 0.5 Plastic Storage Boxes with foam
- #3020-6 Medium Plastic Jewel Storage Boxes - 2.56 x 2.56 x 0.5 Plastic Storage Boxes with foam - 6 pack
- #3020-12 Medium Plastic Jewel Storage Boxes - 2.56 x 2.56 x 0.5 Plastic Storage Boxes with foam - 12 pack
- #3021 Small Plastic Jewel Storage Box - 3.5 x 0.69 x 0.38 Plastic Storage Box
- #3022 Plastic Storage Box, 4 Medium (with foam)& 2 Small Jewel Boxes

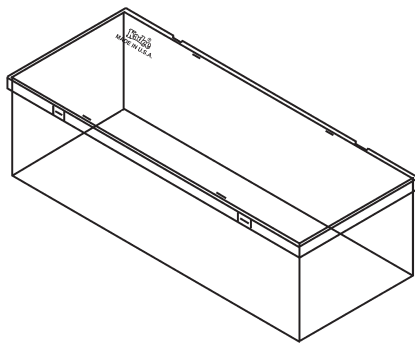

#3000



#3020



#3021



#3022

Drill Size, Decimal Equivalents Chart

DRILL SIZE CHART WITH DECIMAL, FRACTION, WIRE NUMBER AND METRIC SIZES

| Decimal | Inch | Wire mm | Decimal | Inch | Wire mm | Decimal | Inch | Wire mm | Decimal | Inch | Wire mm | Decimal | Inch | Wire mm | Decimal | Inch | Wire mm |
|---------|------|---------|---------|------|---------|---------|------|---------|---------|-------|---------|---------|-------|---------|---------|-------|---------|
| .0135 | | 80 | .0469 | 3/64 | | .0965 | | 2.45 | .1610 | | 20 | .2323 | | 5.90 | .3150 | | 8.00 |
| .0138 | | .35 | .0472 | | 1.20 | .0980 | | 40 | .1614 | | 4.10 | .2340 | | A | .3160 | | O |
| .0145 | | 79 | .0492 | | 1.25 | .0984 | | 2.50 | .1654 | | 4.20 | .2344 | 15/64 | | .3189 | | 8.10 |
| .0156 | 1/64 | | .0512 | | 1.30 | .0995 | | 39 | .1660 | | 19 | .2362 | | 6.00 | .3228 | | 8.20 |
| .0158 | | .40 | .0520 | | 55 | .1015 | | 38 | .1673 | | 4.25 | .2380 | | B | .3230 | | P |
| .0160 | | 78 | .0531 | | 1.35 | .1024 | | 2.60 | .1693 | | 4.30 | .2402 | | 6.10 | .3248 | | 8.25 |
| .0177 | | .45 | .0550 | | 54 | .1040 | | 37 | .1695 | | 18 | .2420 | | C | .3268 | | 8.30 |
| .0180 | | 77 | .0551 | | 1.40 | .1063 | | 2.70 | .1719 | 11/64 | | .2441 | | 6.20 | .3281 | 21/64 | |
| .0197 | | .50 | .0571 | | 1.45 | .1065 | | 36 | .1730 | | 17 | .2460 | | D | .3307 | | 8.40 |
| .0200 | | 76 | .0591 | | 1.50 | .1083 | | 2.75 | .1732 | | 4.40 | .2461 | | 6.25 | .3320 | | Q |
| .0210 | | 75 | .0595 | | 53 | .1094 | 7/64 | | .1770 | | 16 | .2480 | | 6.30 | .3346 | | 8.50 |
| .0217 | | .55 | .0610 | | 1.55 | .1100 | | 35 | .1772 | | 4.50 | .2500 | 1/4 | E | .3386 | | 8.60 |
| .0225 | | 74 | .0625 | 1/16 | | .1102 | | 2.80 | .1800 | | 15 | .2520 | | 6.40 | .3390 | | R |
| .0236 | | .60 | .0630 | | 1.60 | .1110 | | 34 | .1811 | | 4.60 | .2559 | | 6.50 | .3425 | | 8.70 |
| .0240 | | 73 | .0635 | | 52 | .1130 | | 33 | .1820 | | 14 | .2570 | | F | .3438 | 11/32 | |
| .0250 | | 72 | .0650 | | 1.65 | .1142 | | 2.90 | .1850 | | 13 4/70 | .2598 | | 6.60 | .3445 | | 8.75 |
| .0256 | | .65 | .0669 | | 1.70 | .1160 | | 32 | .1870 | | 4.75 | .2610 | | G | .3465 | | 8.80 |
| .0260 | | 71 | .0670 | | 51 | .1181 | | 3.00 | .1875 | 3/16 | | .2638 | | 6.70 | .3480 | | S |
| .0276 | | .70 | .0689 | | 1.75 | .1200 | | 31 | .1890 | | 12 4.80 | .2656 | 17/64 | | .3504 | | 8.90 |
| .0280 | | 70 | .0700 | | 50 | .1220 | | 3.10 | .1910 | | 11 | .2657 | | 6.75 | .3543 | | 9.00 |
| .0292 | | 69 | .0709 | | 1.80 | .1250 | 1/8 | | .1929 | | 4.90 | .2660 | | H | .3580 | | T |
| .0295 | | .75 | .0728 | | 1.85 | .1260 | | 3.20 | .1935 | | 10 | .2677 | | 6.80 | .3583 | | 9.10 |
| .0310 | | 68 | .0730 | | 49 | .1280 | | 3.25 | .1960 | | 9 | .2717 | | 6.90 | .3594 | 23/64 | |
| .0312 | 1/32 | | .0748 | | 1.90 | .1285 | | 30 | .1968 | | 5.00 | .2720 | | I | .3622 | | 9.20 |
| .0315 | | .80 | .0760 | | 48 | .1299 | | 3.30 | .1990 | | 8 | .2756 | | 7.00 | .3642 | | 9.25 |
| .0320 | | 67 | .0768 | | 1.95 | .1339 | | 3.40 | .2008 | | 5.10 | .2770 | | J | .3661 | | 9.30 |
| .0330 | | 66 | .0781 | 5/64 | | .1360 | | 29 | .2010 | | 7 | .2795 | | 7.10 | .3680 | | U |
| .0335 | | .85 | .0785 | | 47 | .1378 | | 3.50 | .2031 | 13/64 | | .2810 | | K | .3701 | | 9.40 |
| .0350 | | 65 | .0787 | | 2.00 | .1405 | | 28 | .2040 | | 6 | .2812 | 9/32 | | .3740 | | 9.50 |
| .0354 | | .90 | .0807 | | 2.05 | .1406 | 9/64 | | .2047 | | 5.20 | .2835 | | 7.20 | .3750 | 3/8 | |
| .0360 | | 64 | .0810 | | 46 | .1417 | | 3.60 | .2055 | | 5 | .2854 | | 7.25 | .3770 | | V |
| .0370 | | 63 | .0820 | | 45 | .1440 | | 27 | .2067 | | 5.25 | .2874 | | 7.30 | .3780 | | 9.60 |
| .0374 | | .95 | .0827 | | 2.10 | .1457 | | 3.70 | .2087 | | 5.30 | .2900 | | L | .3819 | | 9.70 |
| .0380 | | 62 | .0846 | | 2.15 | .1470 | | 26 | .2090 | | 4 | .2913 | | 7.40 | .3839 | | 9.75 |
| .0390 | | 61 | .0860 | | 44 | .1476 | | 3.75 | .2126 | | 5.40 | .2950 | | M | .3858 | | 9.80 |
| .0394 | | 1.00 | .0866 | | 2.20 | .1495 | | 25 | .2130 | | 3 | .2953 | | 7.50 | .3860 | | W |
| .0400 | | 60 | .0886 | | 2.25 | .1496 | | 3.80 | .2165 | | 5.50 | .2969 | 19/64 | | .3898 | | 9.90 |
| .0410 | | 59 | .0890 | | 43 | .1520 | | 24 | .2188 | 7/32 | | .2992 | | 7.60 | .3906 | 25/64 | |
| .0413 | | 1.05 | .0906 | | 2.30 | .1535 | | 3.90 | .2205 | | 5.60 | .3020 | | N | .3937 | | 10.00 |
| .0420 | | 58 | .0925 | | 2.35 | .1540 | | 23 | .2210 | | 2 | .3031 | | 7.70 | .3970 | | X |
| .0430 | | 57 | .0935 | | 42 | .1562 | 5/32 | | .2244 | | 5.70 | .3051 | | 7.75 | .4040 | | Y |
| .0433 | | 1.10 | .0938 | 3/32 | | .1570 | | 22 | .2264 | | 5.75 | .3071 | | 7.80 | | | |
| .0453 | | 1.15 | .0945 | | 2.40 | .1575 | | 4.00 | .2280 | | 1 | .3110 | | 7.90 | | | |
| .0465 | | 56 | .0960 | | 41 | .1590 | | 21 | .2283 | | 5.80 | .3125 | 5/16 | | | | |

©2009, Kadee® Quality Products Co.
673 Avenue C
White City, OR 97503-1078

DECIMAL METRIC EQUIVALENTS

| Fractional Inch | Decimal Inch | Decimal Metric | Fractional Inch | Decimal Inch | Decimal Metric |
|-----------------|--------------|----------------|-----------------|--------------|----------------|
| | 1/64 | .015625 | 33/64 | .515625 | 13.0969 |
| | 1/32 | .03125 | 17/32 | .53125 | 13.4937 |
| | 3/64 | .046875 | 35/64 | .546875 | 13.8906 |
| | 1/16 | .0625 | 9/16 | .5625 | 14.2875 |
| | 5/64 | .078125 | 37/64 | .578125 | 14.6844 |
| | 3/32 | .09375 | 19/32 | .59375 | 15.0812 |
| | 7/64 | .109375 | 39/64 | .609375 | 15.4781 |
| 1/8 | | .125 | 5/8 | .625 | 15.8750 |
| | 9/64 | .140625 | 41/64 | .640625 | 16.2719 |
| | 5/32 | .15625 | 21/32 | .65625 | 16.6687 |
| | 11/64 | .171875 | 43/64 | .671875 | 17.0656 |
| | 3/16 | .1875 | 11/16 | .6875 | 17.4625 |
| | 13/64 | .203125 | 45/64 | .703125 | 17.8594 |
| | 7/32 | .21875 | 23/32 | .71875 | 18.2562 |
| | 15/64 | .234375 | 47/64 | .734375 | 18.6531 |
| 1/4 | | .25 | 3/4 | .75 | 19.0500 |
| | 17/64 | .265625 | 49/64 | .765625 | 19.4469 |
| | 9/32 | .28125 | 25/32 | .78125 | 19.8437 |
| | 19/64 | .296875 | 51/64 | .796875 | 20.2406 |
| | 5/16 | .3125 | 13/16 | .8125 | 20.6375 |
| | 21/64 | .328125 | 53/64 | .828125 | 21.0344 |
| | 11/32 | .34375 | 27/32 | .84375 | 21.4312 |
| | 23/64 | .359375 | 55/64 | .859375 | 21.8281 |
| 3/8 | | .375 | 7/8 | .875 | 22.2250 |
| | 25/64 | .390625 | 57/64 | .890625 | 22.6219 |
| | 13/32 | .40625 | 29/32 | .90625 | 23.0187 |
| | 27/64 | .421875 | 59/64 | .921875 | 23.4156 |
| | 7/16 | .4375 | 15/16 | .9375 | 23.8125 |
| | 29/64 | .453125 | 61/64 | .953125 | 24.2094 |
| | 15/32 | .46875 | 31/32 | .96875 | 24.6062 |
| | 31/64 | .484375 | 63/64 | .984375 | 25.0031 |
| 1/2 | | .5 | 1 | 1.0 | 25.4001 |

Kadee® Spring Specifications

Dimensions in inches / Load in Grams / Material: PB = phosphor bronze, MW = music wire, SS = Stainless Steel

| Part Number (catalog) | Part Number (in house) | Outside Diameter | Inside Diameter | Wire Diameter | Pitch | Total Coils | Free Length | Solid Height | Load (Solid Height) | Closed Coils (per end) | Material |
|-----------------------|------------------------|------------------|-----------------|---------------|-------|-------------|-------------|--------------|---------------------|------------------------|----------|
| 622 | HO-1 | 0.052 | 0.044 | 0.004 | 0.014 | 10.0 | 0.148 | 0.040 | 9.0 | ¾ | PB |
| 623 | HO-2 | 0.052 | 0.046 | 0.003 | 0.012 | 12.0 | 0.148 | 0.036 | 2.5 | ¾ | PB |
| | HO-3 | 0.052 | 0.046 | 0.003 | 0.008 | 15.0 | 0.128 | 0.045 | 2.0 | ¾ | PB |
| 625 | HO-4 | 0.054 | 0.046 | 0.004 | 0.012 | 10.0 | 0.133 | 0.040 | 5.0 | ¾ | PB |
| | HO-T-1 | 0.100 | 0.084 | 0.008 | 0.026 | 7.0 | 0.200 | 0.056 | 50.0 | ¾ | PB |
| 637 | HO-T-2 | 0.080 | 0.066 | 0.007 | 0.021 | 6.0 | 0.140 | 0.042 | 110.0 | ½ | MW |
| 638 | HO-T-3 | 0.062 | 0.048 | 0.007 | 0.024 | 6.5 | 0.170 | 0.045 | 90.0 | ¾ | PB |
| | HO-C-1 | 0.094 | 0.080 | 0.007 | 0.021 | 29.0 | 0.625 | 0.203 | 30.0 | 1 | MW |
| 847 | S-1 | 0.055 | 0.049 | 0.003 | 0.016 | 11.0 | 0.186 | 0.033 | 3.0 | ¾ | PB |
| 846 | S-2 | 0.070 | 0.060 | 0.005 | 0.022 | 8.0 | 0.186 | 0.040 | 14.0 | ¾ | PB |
| 845 | O-1 | 0.070 | 0.060 | 0.005 | 0.024 | 8.0 | 0.208 | 0.040 | 16.0 | 1 | PB |
| 850 | O-2 | 0.110 | 0.096 | 0.007 | 0.029 | 7.0 | 0.218 | 0.049 | 24.0 | ¾ | PB |
| 875 | 1-1 | 0.110 | 0.090 | 0.010 | 0.025 | 12.0 | 0.325 | 0.120 | 95.0 | ¾ | SS |
| 876 | 1-2 | 0.135 | 0.115 | 0.010 | 0.033 | 10.0 | 0.350 | 0.100 | 80.0 | ¾ | SS |
| 877 | 1-3 | 0.104 | 0.084 | 0.010 | 0.029 | 14.0 | 0.425 | 0.140 | 55.0 | ¾ | SS |
| | 1-4 | 0.150 | 0.130 | 0.010 | 0.034 | 7.0 | 0.260 | 0.070 | 50.0 | ¾ | SS |
| 1875 | 1-5 | 0.118 | 0.098 | 0.010 | 0.025 | 12.0 | 0.310 | 0.120 | 75.0 | ¾ | SS |
| | 1-6 | 0.094 | 0.076 | 0.009 | 0.036 | 14.0 | 0.530 | 0.126 | 150.0 | ¾ | SS |
| | 1-7 | 0.074 | 0.060 | 0.007 | 0.021 | 7.5 | 0.170 | 0.052 | 35.0 | ¾ | PB |
| 860 | G-1 | 0.135 | 0.115 | 0.010 | 0.035 | 10.0 | 0.375 | 0.100 | 95.0 | ¾ | SS |
| 861 | G-2 | 0.125 | 0.105 | 0.010 | 0.027 | 22.0 | 0.625 | 0.220 | 50.0 | 1 | SS |
| 864 | G-4 | 0.125 | 0.101 | 0.012 | 0.036 | 19.0 | 0.710 | 0.228 | 220.0 | ¾ | SS |
| | G-6 | 0.125 | 0.105 | 0.010 | 0.033 | 16.0 | 0.550 | 0.160 | 85.0 | 1 | SS |
| | G-9 | 0.114 | 0.098 | 0.008 | 0.023 | 10.0 | 0.250 | 0.080 | 30.0 | ¾ | SS |
| 878 | G-39 | 0.155 | 0.135 | 0.010 | 0.046 | 12.0 | 0.580 | 0.120 | 60.0 | ¾ | SS |
| | 701 | 0.165 | 0.137 | 0.014 | 0.057 | 19.0 | 1.125 | 0.266 | 350.0 | 1 | MW |
| | 702 | 0.135 | 0.117 | 0.009 | 0.040 | 27.0 | 1.100 | 0.243 | 90.0 | 1 | MW |

SUMMARY OF SCALES

| NAME OF SCALE | SCALE TO FOOT | PROPORTION | COUPLER CENTER ABOVE RAILHEAD | TRACK GAGE |
|---------------|-----------------|------------|-------------------------------|-------------------|
| 1-1/2" | 1.500" (38.1mm) | 1:8 | 4 5/16" (109mm) | 7.250" (184.15mm) |
| 1-1/2" | 1.500" (38.1mm) | 1:8 | 4 5/16" (109mm) | 7.500" (190.5mm) |
| 1" | 1.000" (25.4mm) | 1:12 | 2 7/8" (73mm) | 4.750" (121mm) |
| M | .886" (22.5mm) | 1:13.5 | | 4.173" (106mm) |
| Mn2 | .886" (22.5mm) | 1:13.5 | | 1.772" (45mm) |
| 3/4" | .75" (19mm) | 1:16 | 2 1/4" (57mm) | 3.500" (88.9mm) |
| F | .591" (15mm) | 1:20.3 | | 2.776" (70.5mm) |
| Fm | .591" (15mm) | 1:20.3 | | 1.949" (49.5mm) |
| Fn3 | .591" (15mm) | 1:20.3 | | 1.772" (45mm) |
| Fn2-1/2 | .591" (15mm) | 1:20.3 | | 1.476" (37.5mm) |
| Fn2 | .591" (15mm) | 1:20.3 | | 1.181" (30mm) |
| G | .533" (13.55mm) | 1:22.5 | | 2.519" (64mm) |
| Gm | .533" (13.55mm) | 1:22.5 | | 1.772" (45mm) |
| Gn3 | .533" (13.55mm) | 1:22.5 | | 1.614" (41mm) |
| Gn2-1/2 | .533" (13.55mm) | 1:22.5 | | 1.259" (32mm) |
| 17/32" | .531" (13.5mm) | 1:22.6 | 1 7/16" (37mm) | 2.500" (63.5mm) |
| 1/2" | .500" (12.7mm) | 1:24 | 1 7/16" (37mm) | 2.500" (63.5mm) |
| A | .414" (10.51mm) | 1:29 | | 1.949" (49.5mm) |
| An3-1/2 | .414" (10.51mm) | 1:29 | | 1.476" (37.5mm) |
| An2-1/2 | .414" (10.51mm) | 1:29 | | 1.259" (32mm) |
| An2 | .414" (10.51mm) | 1:29 | | .886" (22.5mm) |
| #1 | .375" (9.52mm) | 1:32 | 1 1/16" (27mm) | 1.766" (45mm) |
| #1m | .375" (9.52mm) | 1:32 | | 1.259" (32mm) |
| #1n3 | .375" (9.52mm) | 1:32 | | 1.126" (28.6mm) |
| #1n2 | .375" (9.52mm) | 1:32 | | .752" (19.1mm) |
| O(17) | .266" (6.75mm) | 1:45.2 | 11/16" (17mm) | 1.250" (31.8mm) |
| O | .250" (6.35mm) | 1:48 | 11/16" (17mm) | 1.250" (31.8mm) |
| On3 | .250" (6.35mm) | 1:48 | 9/16" (14mm) | .750" (19.0mm) |
| On30 (On2.5) | .250" (6.35mm) | 1:48 | See HO or On3 | .649" (16.5mm) |
| On2 | .250" (6.35mm) | 1:48 | 11/32" (8.7mm) | .500" (12.7mm) |
| S | .188" (4.76mm) | 1:64 | 17/32" (13mm) | .875" (22.2mm) |
| Sn3 | .188" (4.76mm) | 1:64 | 13/32" (10mm) | .563" (14.3mm) |
| OO | .1575" (4mm) | 1:76.2 | 29/64" (12mm) | .750" (19mm) |
| HO | .1378" (3.5mm) | 1:87.1 | 25/64" (9.9mm) | .649" (16.5mm) |
| HOn3 | .1378" (3.5mm) | 1:87.1 | 9/32" (7.1mm) | .413" (10.5mm) |
| HOn2 | .1378" (3.5mm) | 1:87.1 | | .276" (7.01mm) |
| TT | .100" (2.54mm) | 1:120 | 9/32" (7.1mm) | .471" (12mm) |
| TTn3 | .100" (2.54mm) | 1:120 | 7/32" (5.54mm) | .300" (7.62mm) |
| N | .075" (1.90mm) | 1:160 | .216" (5.5mm) | .353" (8.97mm) |
| Nn3(40") | .075" (1.90mm) | 1:160 | | .250" (6.35mm) |
| Z | .055" (1.39mm) | 1:220 | | .257" (6.52mm) |

**Kadee[®] Quality
Products Co.**

**673 AVENUE C
WHITE CITY, OR 97503-1078
(541) 826-3883 FAX: (541) 826-4013
www.kadee.com mail@kadee.com**

Kadee® - RC System

KADEE® RC

Kadee® RC Remote System

Uncouple Anywhere*

Truly Wireless
Additional Auxiliary Features
No Track Signal Needed
Stand-Alone System

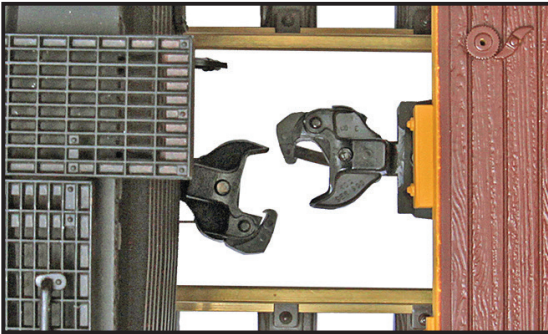

Open & Close Large Scale Couplers with a Push of a Button.

Turn On and Off lighting, switches, turnouts, motors and more... with a Push of a Button.

NEW



TRUE WIRELESS IS HERE

Kadee® RC Brings the Best of Old & New Technologies Together.
Kadee® Magne-Matic® Couplers & Kadee® RC Remote System.

The Exciting New Series of G-Scale Kadee® RC Couplers can be operated with your existing Kadee® magnetic uncouplers and also uncouple remotely anywhere* with the NEW (patent pending) Kadee® Radio Control System.

By incorporating Kadee® RC Radio Control System in to your layout, you can bring the best of old & new technologies together. Kadee® Magne-Matic® Remote Couplers can be operated by any one of the Kadee® uncouplers you already have in your layout or they can be operated independently using the Kadee® RC Hand-Held Transmitter that can operate remote couplers, lighting, switches, turnouts, motors and more. Up to 99 Receivers can be operated from just one Transmitter.

Current Features:

- Auto Shutdown
- Group Operation
- Long Battery Life
- Battery Monitoring
- Up to a 300' range
- Remote Uncoupling

- Large Tactile Keypad
- Stand Alone Operation
- Multiple Operating Modes
- Simple Addressing & Binding
- Operate up to 99 Remote Devices
- Receiver with On-board 250mA Relay

- Monitor Receiver Status in LCD Display
- Accommodates Standard Hobby Servos

Patents Pending, Patent numbers 7,810,660 B1



Quality Products Co.
673 Avenue C,
White City, OR 97503-1078



Made & Assembled Entirely
in the U.S.A.

© 2013, Kadee® Quality Products Co.



* Limited uncoupling on curves.

FOR MORE INFORMATION VISIT
www.remoteuncoupling.com

Kadee® - RC System

Components

Hand-Held Transmitter

The Kadee® RC Hand-Held Transmitter can operate remote couplers, lighting, switches, turnouts, motors and more, up to 99 Receivers can be operated from just one Hand-Held Transmitter.
Batteries not included.

#11215 Hand-Held Transmitter

Current Features:

- Auto Shutdown
- Group Operation
- Long Battery Life
- Battery Monitoring
- Up to a 300' range
- Remote Uncoupling
- Large Tactile Keypad
- Stand Alone Operation
- Multiple Operating Modes
- Simple Addressing & Binding
- Operate up to 99 Remote Devices
- Receiver with On-board 250mA Relay
- Monitor Receiver Status in LCD Display
- Accommodates Standard Hobby Servos



Hand-Held Transmitter

Receiver Kit

The Kadee® RC Receiver can operate the One Standard Hobby Servo and has a built in 250mA Relay For lighting, switches, turnouts, motors and more. **Batteries not included.**

For use with the #11215 Hand-Held Transmitter sold separately.

Note: Powering the Receiver from any other power source will void the warranty.

#11110 Receiver Kit

Includes: One Receiver Module, One 4 cell AA Battery Holder, One Wiring Harness, Fuse & Fuse Holder.

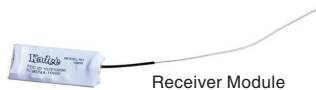

Receiver Module



Wiring Harness



Fuse & Fuse Holder



4 cell AA Battery Holder

Standard Servo Kit

#11120 Standard Servo Kit

Includes: One Hitec (HS-311) Servo, One Standard Vertical Servo Tray, Four 1/8 X 1/4 X 1/16" Grommets, Four Eyelets, Two #4 X 1/4" Screws, Alcohol Wipe, Double Sided Tape.

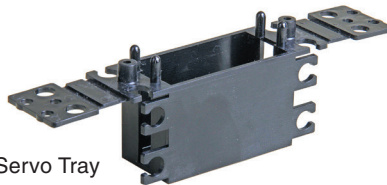

Standard Vertical Servo Tray



Hitec (HS-311) Servo

Standard Vertical Servo Tray - for Hitec (HS-311)

#11200 Standard Vertical Servo Tray - for Hitec (HS-311)

Includes: One Servo Tray, Four 1/8 X 1/4 X 1/16" Grommets, Four Eyelets, Two #4 X 1/4" Screws, Alcohol Wipe, Double Sided Tape.

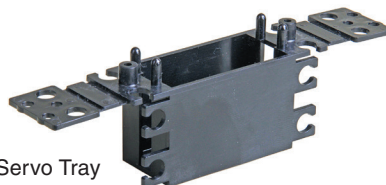

Standard Vertical Servo Tray

Patents Pending

Kadee® - RC System

Components

Starter Kits

This package of Kadee® products is designed to get you started with Kadee® RC System. The kit contains all the necessary hardware to convert one body mount large-scale car to a remote uncoupling car with an auxiliary 250mA power relay. **Batteries not included.**

#11100 G-Scale Body Mount Coupler Starter Kit (single or dual remote uncoupling)

Designed for use with Freight & Passenger cars. Includes the following products:

#11215 Hand-Held Transmitter, #11110 Receiver Kit, #11115 Body Mount Coupler Kit

#11105 G-Scale Actuated Body Mount Coupler Starter Kit (single remote uncoupling)

Designed for use with Locomotives, Freight & Passenger cars. Includes the following products:

#11215 Hand-Held Transmitter, #11110 Receiver Kit, #11220 Actuated Body Mount Coupler with Gearbox (Assembled)

Body Mount Remote Coupler Kit *Designed for use with Freight & Passenger cars.*

The Kit includes the necessary components to convert both ends of one car to Remote Couplers. The #11115 Kit includes #906 couplers that will body mount anywhere a #830 coupler will. The car can be setup to remotely operate a single coupler or both couplers simultaneously.

If Kadee® RC Remote System is being used to operate Remote Coupler, the #11110 Receiver Kit (sold separately) is needed.

*We recommend operating Kadee® RC Remote Couplers using the Kadee® RC Remote System, other means of operating & controlling the servo can be used with Kadee® RC Remote Couplers, as long as the degree of servo rotation is adjustable. The Kadee® RC Remote Couplers are designed to operate with 90 degree servo rotation only. **Note: The use of any other means of operating the Kadee® RC Remote Couplers other than a Kadee® RC Servo Controller (Example: #11110 Receiver Kit) will void the warranty.***

#11115 G-Scale Body Mount Coupler Kit (single or dual remote uncoupling)

Contains: Two #906 G-Scale Couplers & Gearboxes, Two Trip Pin Linkage Collars, Two Short Linkage Rods, One Long Linkage Rod, Two #841 Shims, Mounting Screws & Hardware, One #11120 Standard Servo Kit (One One Hitec (HS-311) Servo, One Standard Vertical Servo Tray, Four 1/8 X 1/4 X 1/16" Grommets, Four Eyelets, Two #4 X 1/4" Screws, Alcohol Wipe, Double Sided Tape).

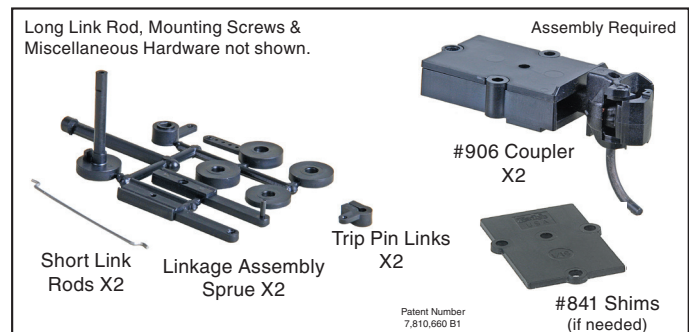
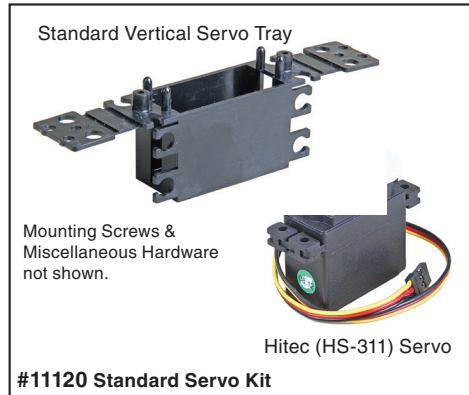

Actuated Body Mount Coupler with Gearbox *Designed for use with Locomotives, Freight & Passenger cars.*

This product allows you to convert to a Remote Coupler easily. The #1 & G Scale Actuated Body Mount Gearboxes are the same & will body mount anywhere a #830 gearbox will mount. The #11220 will mount on a #830 platform and be at the #830 G-Scale coupler height. The #11221 will mount on a #830 platform and be at the #820 #1-Scale coupler height. Couplers can be custom body mounted to most locomotives. The kit contains one ready to mount assembled "all in one remote coupler" (coupler and gearbox with built in ultra nano servo).

If Kadee® RC Remote System is being used to operate Remote Coupler, the #11110 Receiver Kit (sold separately) is needed.

*We recommend operating Kadee® RC Remote Couplers using the Kadee® RC Remote System, other means of operating & controlling the servo can be used with Kadee® RC Remote Couplers, as long as the degree of servo rotation is adjustable. The Kadee® RC Remote Couplers are designed to operate with 90 degree servo rotation only. **Note: The use of any other means of operating the Kadee® RC Remote Couplers other than a Kadee® RC Servo Controller (Example: #11110 Receiver Kit) will void the warranty.***

#11220 G-Scale Actuated Body Mount Coupler with Gearbox (Assembled)

#11221 #1-Scale Actuated Body Mount Coupler with Gearbox (Assembled)

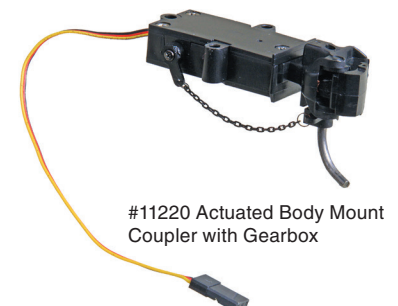

Kadee® - RC System

Components

Servo Controller

Adds servo control to DCC, AirWire, Bluetooth, or other locomotive control decoders with auxiliary/function output. Allows control of Kadee® RC Remote Couplers (factory programmed), turnouts, crossing gates, semaphores, windmills, water wheels, gondolas, trams, roundabouts, cranes, & drawbridges...

Note: The #11130 Servo Controller is equipped with a On-board 250mA Relay for lighting or other remote switching needs.

#11130 Servo Controller (DCC, AirWire, etc.)

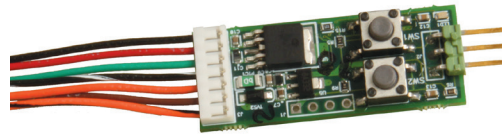

LIMITED WARRANTY

Kadee Quality Products will repair or replace, at our sole option without charge, any Kadee Remote Control Product or Kadee Remote Control system products affiliated with Kadee Remote Control system (#11110, #11130, #11215, #11225, #11230) determined by Kadee to be defective, where such product fails due to a defect in material or workmanship within (1) Year following the initial consumer purchase. Kadee's responsibility and liability pursuant to this warranty is expressly and solely limited to the replacement and repair of the Kadee Product in accordance with this warranty.

This warranty is limited to the original "Purchaser" and is not transferable or assignable. This warranty covers only those Kadee Products purchased from an authorized dealer. Third party transactions (such as EBAY) are not covered by this warranty.

Proof of purchase or product registration reflecting a purchase within the warranty period is required for warranty claims. Further, Kadee reserves the right to change or modify this warranty without notice and disclaims all other warranties, express or implied.

This warranty does not cover: normal wear and tear, cosmetic or physical damage to the surface of the product, including cracks or scratches. Any damage due to improper installation, operation, maintenance, handling, accident, fire, water or liquids, power changes, abuse, alteration, modification, negligence, battery leak, damage caused by third parties, damage due to attempted repair by anyone other than Kadee, acts of God, devices purchased from anyone other than an authorized retailer or distributor or devices that have been previously registered.

This warranty is considered void if the product case has been opened or the protective wrap has been removed by anyone other than Kadee.

Any device needing to be returned to Kadee must have a return merchandise authorization (RMA) number. Any device received at Kadee without a valid RMA number will be returned to the sender at sender's expense. RMA numbers are valid for (10) business days.

Kadee reserves the right to inspect any and all equipment involved in a warranty claim. Repair or replacement decisions are at the sole discretion of Kadee.

A technical representative will be able to determine if the device is defective and still under the limited warranty period. It also may be necessary for the device to be sent for evaluation to determine the validity of the warranty claim.

If the device is not deemed defective or is out of the limited warranty period, you may be given the option to repair the device for a fee or have the device returned as is at your expense.

DISCLAIMER:

REPAIR OR REPLACEMENT AS PROVIDED UNDER THIS WARRANTY IS YOUR EXCLUSIVE REMEDY. THIS WARRANTY IS IN LIEU OF ALL OTHER EXPRESS OR IMPLIED WARRANTIES. KADEE SHALL NOT BE RESPONSIBLE OR LIABLE FOR ANY SPECIAL, INCIDENTAL OR CONSEQUENTIAL DAMAGES FOR BREACH OF ANY EXPRESS OR IMPLIED WARRANTY ON THIS PRODUCT, EXCEPT TO THE EXTENT PROHIBITED BY LAW. ANY IMPLIED WARRANTY, INCLUDING THE WARRANTY OF MERCHANTABILITY OR THE WARRANTY OF FITNESS FOR A PARTICULAR PURPOSE ON THIS PRODUCT IS LIMITED IN DURATION TO THE TERM OF THIS WARRANTY. Some states/countries do not allow limitations of how long an implied warranty lasts or the exclusion or limitation of such damages, so these limitations and exclusions may not apply to you. This warranty gives the consumer specific legal rights and you may also have other rights which vary from location to location. If any portion of this warranty is held to be invalid or unenforceable for any reason, such finding will not invalidate any other provision.

Note: Powering the #11110 Receiver Kit from any other power source will void the warranty.

Note: The use of any other means of operating the Kadee® RC Remote Couplers other than a Kadee® RC Controller (Example: #11110 Receiver Kit or #11130 Servo Controller) will void the warranty.

