



Uncouple Anywhere*

Truly Wireless
 Additional Auxiliary Features
 No Track Signal Needed
 Stand-alone System

#11100 Basic Starter Kit (single or dual)\$344.99

Includes - #11215 Hand-Held Transmitter, #11115 Body Mount Coupler Kit (G-Scale), & #11110 Receiver Kit

Designed for use with Freight & Passenger cars.

Basic Starter Kit will help you to get started with Kadee-RC Remote uncoupling system. The Kit includes the necessary components to convert both ends of one Freight or Passenger car to Remote Couplers. The #11115 Coupler Kit that is included, includes a standard size servo (that will need to be mounted inside the car where space allows) to operate the body mounted #906 couplers. The car can be setup to remotely operate a single coupler or both couplers simultaneously. The #11110 Receiver Kit that is included mounts anywhere space allows.

Your Kadee-RC Remote Couplers will operate and function with standard Kadee® G-Scale Couplers. The Remote Couplers will operate with the Kadee-RC #11215 Hand-Held Transmitter that is included or operate over Kadee® Magnetic uncouplers.

Note: The #11110 Receiver Kit is equipped with a On-board 250mA Relay for lighting or other remote switching needs.



Boxcar shell removed

Car not included

Patent Pending

#11100 Includes



Hand-Held Transmitter

Long Link Rod, Mounting Screws & Miscellaneous Hardware not shown.

Standard Vertical Servo Tray



Short Link Rods X2

Linkage Assembly Sprue X2

Trip Pin Links X2



Wiring Harness



Hitec (HS-311) Servo



#906 Coupler X2

Assembly Required

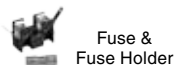

Fuse & Fuse Holder



4 cell AA Battery Holder



Receiver Module



#841 Shims (if needed)

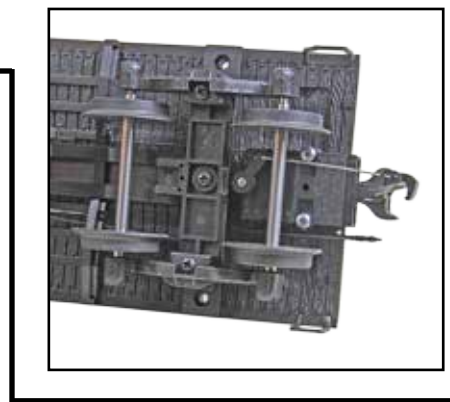

CNW, DRGW, MKT, MP, SP, SSW, UP, & WP marks are made under trademark license from Union Pacific Railroad Company.

⚠WARNING: CHOKING HAZARD - Small Parts - Not for children under 14 years.

Lettering similar to cars shown *Subject to change without notice.



Uncouple Anywhere*

Truly Wireless
 Additional Auxiliary Features
 No Track Signal Needed
 Stand-alone System

#11105 Self Contained Coupler Starter Kit (single).....\$359.99

Includes - #11215 Hand-Held Transmitter, #11220 Actuated Body Mount Coupler with Gearbox (G-Scale) , & #11110 Receiver Kit

This Kit is designed for use with Locomotives, Freight & Passenger cars. Self Contained Coupler Starter Kit is the easiest way to get started with Kadee-RC Remote uncoupling system.

The Kit includes the necessary components to convert one end of a car. The #11220 Coupler is designed for locomotives & rolling stock where appropriate coupler mounting space allows. The #11220 is an factory assembled self contained coupler & gearbox with built in ultra nano servo, that fits anywhere a #830 coupler will mount and can be custom body mounted to most locomotives. This all in one gearbox and servo design saves valuable space. Eliminating the need to mount a standard size servo inside the car, giving a easy remote coupler mounting option. The #11110 Receiver Kit that is included, can be mounted inside or underneath the locomotive, boxcar or passenger car where space allows.

The car will be setup to remotely operate a single remote coupler, a second #11220 Coupler (sold separately) can be operated simultaneously with the use of a servo Y splitter cable (sold separately).

Your Kadee-RC Remote Couplers will operate and function with standard Kadee® G-Scale Couplers. The Remote Couplers will operate with the Kadee-RC #11215 Hand-Held Transmitter that is included or operate over Kadee® Magnetic uncouplers.

Note: The #11110 Receiver Kit is equipped with a On-board 250mA Relay for lighting or other remote switching needs.

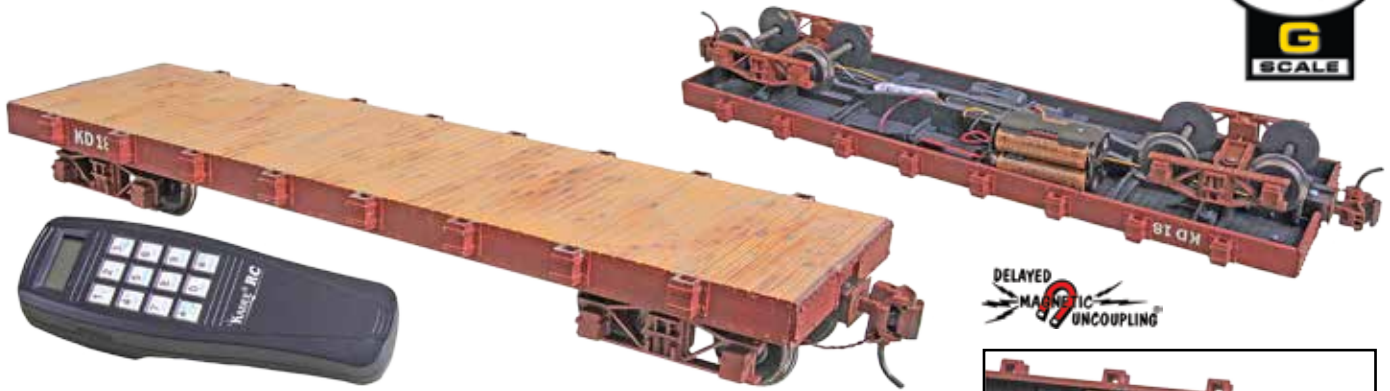

Car not included

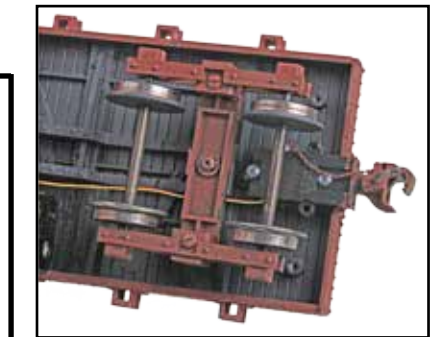

Easy Installation

#11105 Includes



Hand-Held Transmitter

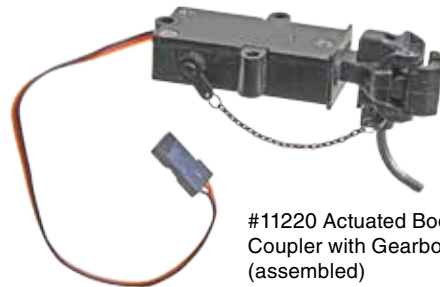

#11220 Actuated Body Mount Coupler with Gearbox (assembled)



4 cell AA Battery Holder

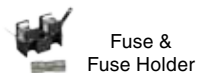

Fuse & Fuse Holder



Wiring Harness

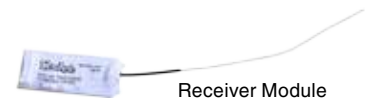

Receiver Module

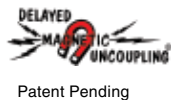

CNW, DRGW, MKT, MP, SP, SSW, UP, & WP marks are made under trademark license from Union Pacific Railroad Company.

⚠️WARNING: CHOKING HAZARD - Small Parts - Not for children under 14 years.

Lettering similar to cars shown *Subject to change without notice.

#11115 G-Scale Body Mount Coupler Kit. \$39.99

Designed for use with Freight & Passenger cars.

The Kit includes the necessary components to convert both ends of one car to Remote Couplers. The #11115 Coupler Kit includes a standard size servo (that will need to be mounted inside the car where space allows) to operate the body mounted #906 couplers. The car can be setup to remotely operate a single coupler or both couplers simultaneously.

If #11215 Kadee® RC Hand-Held Transmitter (sold separately) is being used to operate Remote Coupler, the #11110 Receiver Kit (sold separately) is needed to allow the Hand-Held Transmitter to communicate with servo.

We recommend operating Kadee® RC Remote Couplers using the Kadee® RC Remote System, other means of operating & controlling the standard hobby servos can be used with Kadee® RC Remote Couplers, as long as the degree of servo rotation is adjustable. The Kadee® RC Remote Couplers are designed to operate with 90 degree servo rotation only.



Car not included

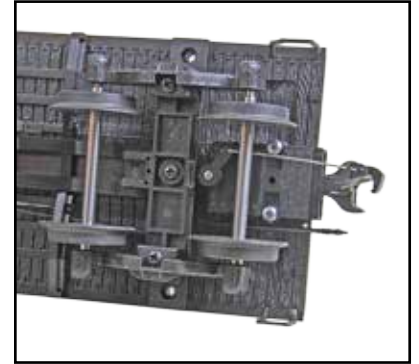

Long Link Rod, Mounting Screws & Miscellaneous Hardware not shown. Standard Vertical Servo Tray Assembly Required

Short Link Rods X2 Linkage Assembly Sprue X2 Trip Pin Links X2 #906 Coupler X2 Hitec (HS-311) Servo #841 Shims (if needed)

#11115 Body Mount Coupler Kit

Patent Number 7,810,660 B1 & Patent Pending



#11220 G-Scale Actuated Body Mount Coupler with Gearbox. \$49.99

Designed for use with Locomotives, Freight & Passenger cars.

This product allows you to convert to a Remote Coupler easily. The #1 & G-Scale Actuated Body Mount Gearboxes are the same & will body mount anywhere a #830 gearbox will mount. The #11220 will mount on a #830 platform and be at the #830 G-Scale coupler height. Couplers can be custom body mounted to most locomotives. The kit contains one ready to mount assembled "all in one remote coupler" (coupler and gearbox with built in ultra nano servo). The car can be setup to remotely operate a single coupler or a second remote coupler (sold separately) simultaneously with the use of a servo Y splitter cable (sold separately).

If #11215 Kadee® RC Hand-Held Transmitter (sold separately) is being used to operate Remote Coupler, the #11110 Receiver Kit (sold separately) is needed to allow the Hand-Held Transmitter to communicate with servo.

We recommend operating Kadee® RC Remote Couplers using the Kadee® RC Remote System, other means of operating & controlling the standard hobby servos can be used with Kadee® RC Remote Couplers, as long as the degree of servo rotation is adjustable. The Kadee® RC Remote Couplers are designed to operate with 90 degree servo rotation only.

Easy Installation

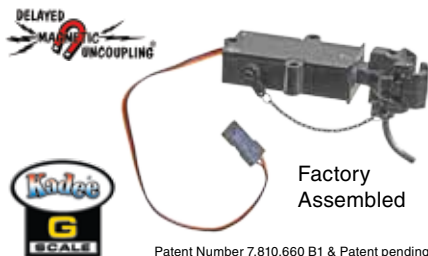

Factory Assembled

Patent Number 7,810,660 B1 & Patent pending

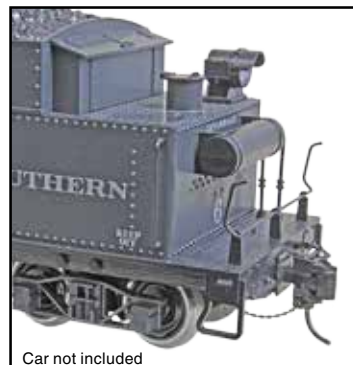

Car not included



CNW, DRGW, MKT, MP, SP, SSW, UP, & WP marks are made under trademark license from Union Pacific Railroad Company.

⚠ WARNING: CHOKING HAZARD - Small Parts - Not for children under 14 years.

Lettering similar to cars shown *Subject to change without notice.

#11221 #1-Scale Actuated Body Mount Coupler with Gearbox. \$49.99

Designed for use with Locomotives, Freight & Passenger cars.

This product allows you to convert to a Remote Coupler easily. The #1 & G Scale Actuated Body Mount Gearboxes are the same & will body mount anywhere a #830 gearbox will mount. The #11221 will mount on a #830 platform and be at #1-Scale coupler height. Couplers can be custom body mounted to most locomotives. The kit contains one ready to mount assembled "all in one remote coupler" (coupler and gearbox with built in ultra nano servo). The car can be setup to remotely operate a single coupler or a second coupler (sold separately) simultaneously with the use of a servo Y splitter cable (sold separately).

If #11215 Kadee® RC Hand-Held Transmitter (sold separately) is being used to operate Remote Coupler, the #11110 Receiver Kit (sold separately) is needed to allow the Hand-Held Transmitter to communicate with servo.

We recommend operating Kadee® RC Remote Couplers using the Kadee® RC Remote System, other means of operating & controlling the standard hobby servos can be used with Kadee® RC Remote Couplers, as long as the degree of servo rotation is adjustable. The Kadee® RC Remote Couplers are designed to operate with 90 degree servo rotation only.

Easy Installation

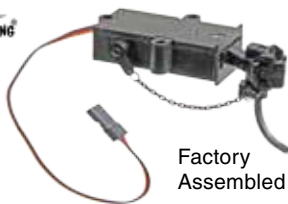

Factory Assembled

Patent Number 7,810,660 B1 & Patent pending



Car not included



#11110 Receiver Kit \$128.99

The #11110 Receiver is required for the #11215 Hand-Held Transmitter to communicate with car. The #11110 Receiver interrupts the commands given by the #11215 Hand-Held Transmitter and either operates the Standard Hobby Servo or On-board 250mA Relay.

Note: The #11110 Receiver Kit is equipped with a On-board 250mA Relay for lighting or other remote switching needs.

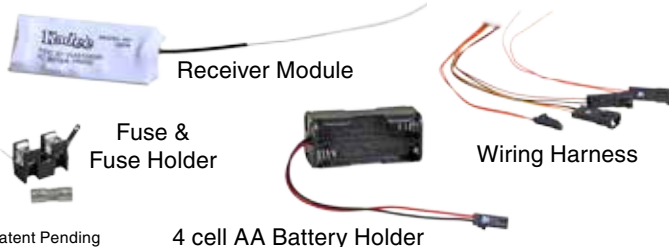

Patent Pending

4 cell AA Battery Holder

#11120 Standard Servo Kit \$25.99

This Kit contains a Hitec (HS-311) Servo, a Vertical Servo Tray and mounting hardware. Replacement standard size servo or for animating objects on layout.



Standard Vertical Servo Tray - for Hitec (HS-311)

Hitec (HS-311) Servo

Mounting Screws & Miscellaneous Hardware Included.

#11200 Standard Vertical Servo Tray . . . \$5.99

Replacement servo tray for Hitec (HS-311) Servo. The servo tray is a one piece plastic design.

Standard Vertical Servo Tray - for Hitec (HS-311)



Mounting Screws & Miscellaneous Hardware Included.

#11215 Hand-Held Transmitter . . \$199.99

The #11215 Hand-Held Transmitter is the Kadee-RC Remote uncoupling systems controller. The #11215 Hand-Held Transmitter is uniquely addressed so it will not interfere with other #11215 Hand-Held Transmitters. So there is no need to worry about any interference from club layouts where multiple #11215 Hand-Held Transmitters may be in use. Each #11215 Hand-Held Transmitter will operate up to 99 Remote Devices and has up to a 300' range.

Current Features:

- Auto Shutdown
- Group Operation
- Long Battery Life
- Battery Monitoring
- Up to a 300' range
- Remote Uncoupling
- Large Tactile Keypad
- Stand Alone Operation
- Multiple Operating Modes
- Simple Addressing & Binding
- Operate up to 99 Remote Devices
- Receiver with On-board 250mA Relay
- Monitor Receiver Status in LCD Display



Hand-Held Transmitter

Patent Pending